

The Grace EZ3 Fabri-Fast Quilting Frame

Instruction Manual (3-Size Frame)

Table of Contents

Care, Finishing, and Storage	2
Warranty	2
Parts List	3
Hardware List.	4

Assembly Steps

Step 1: Hardware to leg assembly.	5
Step 2: Hardware to tilt head	6
Step 3: Feet to leg assembly.	7
Step 4: Tilt head to legs assembly.	8
Step 6: Hardware to brace assembly	9
Step 7: 36 inch brace assembly.	9
Step 8: Middle brace assembly	10
Step 9: Crib/queen brace assembly	10
Step 10: Brace to right and left side assembly	11
Step 11: Ratchet wheels and rail assembly.	12
Step 12: Rail to frame assembly	14
Step 13: Ratchet stop assembly	14
Assembly & use of accessories.	15
Tilting the EZ3 fabri-fast	15
Folding the EZ3 fabri-fast	16
Quilting on the EZ3-fabri-fast.	17
Preparing the fabric layers for installation	17
Fabric installation	17
Method #1: Preparing and using The Grace Company Optional StartRight™ cloth leaders	17
Method #2: Making and using (DIY) cloth leaders	19
Applying quilt fabric to cloth leader	20
Method #3: Installing the fabric directly to the rails.	23
Troubleshooting	24
Tips for tying quilts.	24

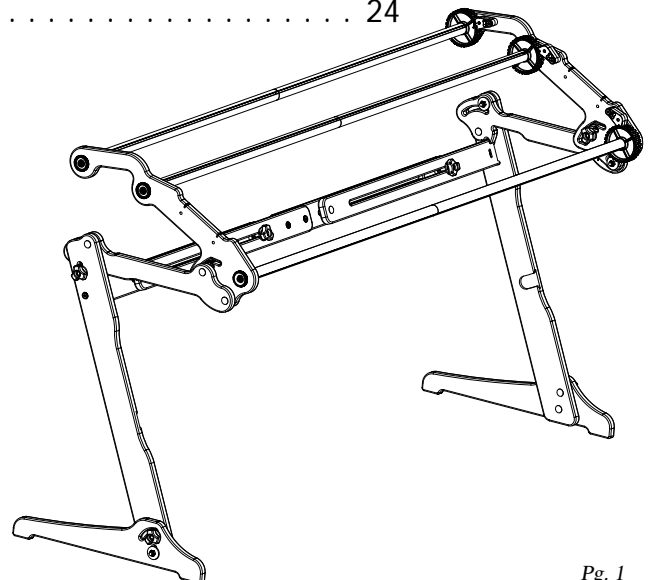

Care, Finishing, and Storage

Your EZ3™ Fabri-Fast Quilting Frame is a sturdy frame that can be used finished or unfinished. For extra protection, or to give it a finished look, you may seal, stain and/or finish the frame using a number of different applications. This is best done BEFORE YOU ASSEMBLE your frame.

To seal the wood, we recommend an application of tung oil that will help preserve the wood and will help to prevent warping. To add a certain color to your frame, you may use a Danish Oil finish. We recommend the Deft™ or Watco™ brands. Some prefer to use a urethane coat to add a more glossy furniture like finish.

Test stain on an inconspicuous place. Many different finishes and/or stains may be suitable for sealing and beautifying your frame. You may want to consult your local paint retailer for finishes that are easy to apply and dry hard—not oily.

Use and Storage Tips

--Store frame in a dry place. If not assembled, store with braces in vertical position. (This will prevent floor moisture from seeping into the Braces).

--Do not carry the assembled frame by the quilting rails. Hold the braces instead.

--Do not drop the frame or let it twist out of square.

Warranty

Limited 1 year Warranty

GraceWood, Inc. Will replace or repair, at our choosing, any part of the Grace EZ3™ Fabri-Fast Quilting Frame, which may be shown to be defective. This warranty does not cover parts damaged through misuse, improper storage, improper assembly, loss, natural events and willful or accidental destruction. Defective parts may be returned only with a valid RMA# which may be obtained by calling:

GraceWood, Inc. at **1-800-264-0644**.

*Warranty card must be filled out, stamped and mailed to the address on the card **within 30 days of purchase**.*

Contact Information

For Technical Support or any other correspondence concerning your EZ3™ Fabri-Fast Quilting Frame, call **1-800-264-0644**

OR ~ E-mail: info@graceframe.com ~ OR ~ Fax: (801) 908-8888 ~

OR ~ Write to:

The Grace Company

P.O. Box 27823

Salt Lake City, UT 84127

For details on accessories and other information, see us online at www.graceframe.com

For shipping of materials to The Grace Company address package (postage prepaid) to:

The Grace Company

2225 South 3200 West

Salt Lake City, UT 84119.

Materials may be returned only with a valid RMA# or Returned Merchandise Authorization Number which may be obtained by calling GraceWood, Inc. at **1-800-264-0644**.

If you call after business hours (M-F 8:00 a.m. – 5 p.m., MST) be assured that your call will be returned the next business day if you leave a message. Please report any errors in these instructions or make constructive comments to the following: info@graceframe.com

Grace Quilting Frames and Hoops: Innovation and Evolution

Grace Quilting Systems have been developed over the past two decades with several original design innovations. Additionally, because feedback from many of the thousands of quilters who have purchased and use the GraceFrame, we have been able to make a frame that will truly enhance the entire process of hand quilting from beginning to end. If you have any suggestions that will help us to improve our product or service, let us know, using one of the above contact methods.

Parts List

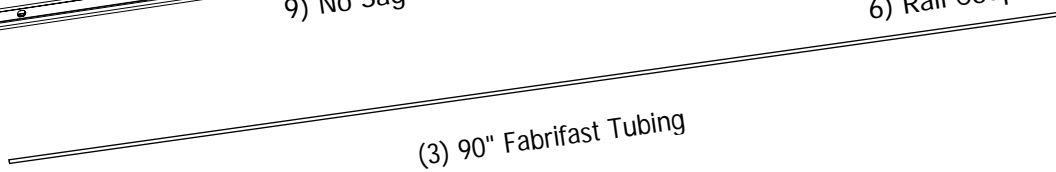
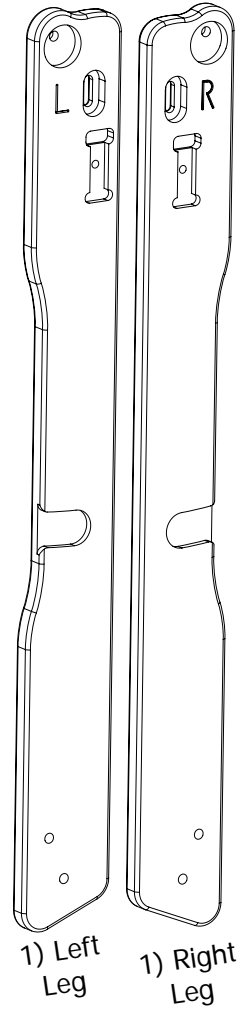
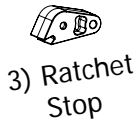
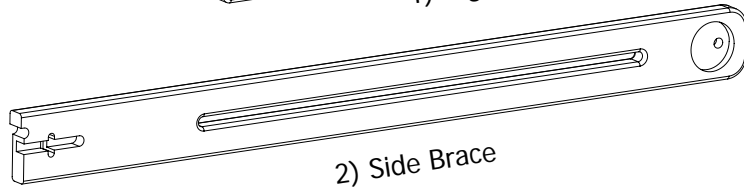
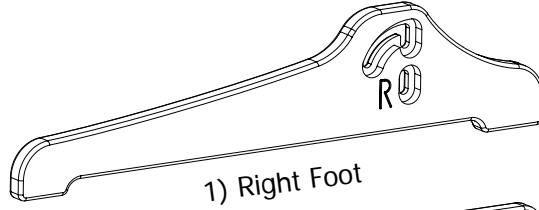
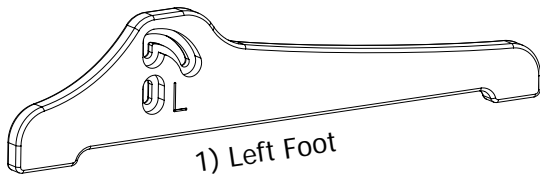
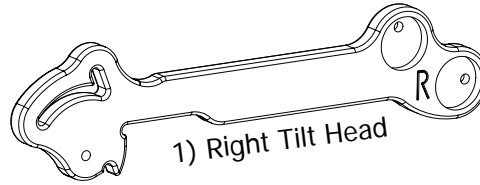
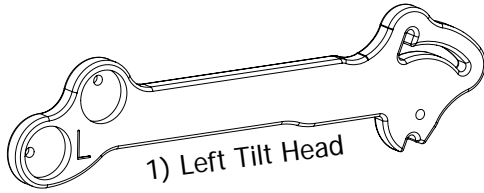
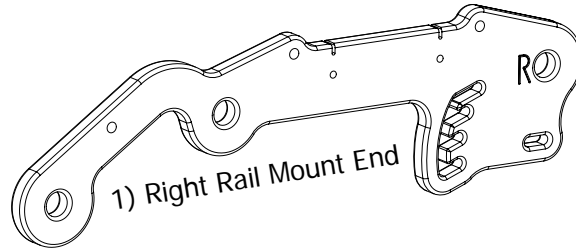
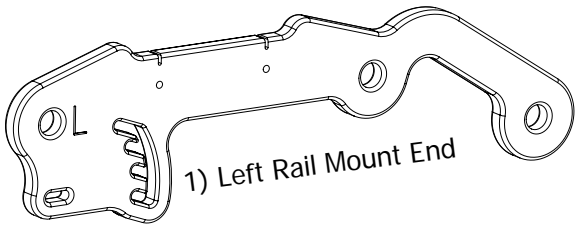

Hardware List

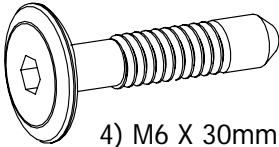

4) M6 X 30mm
Connector Bolt

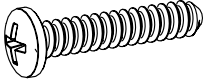

6) 30mm Screw

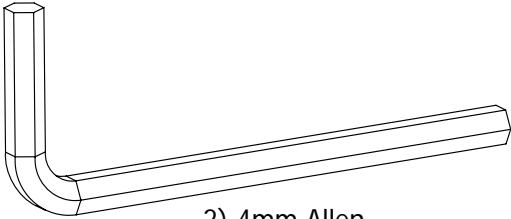

2) 4mm Allen
Wrench



6) M5 Square Nut
(Pre-Installed)

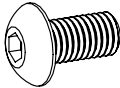

18) M5 X 10mm
Screw

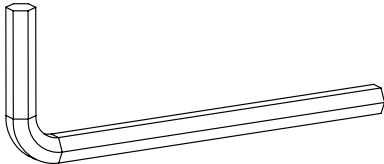

1) 3mm Allen
Wrench

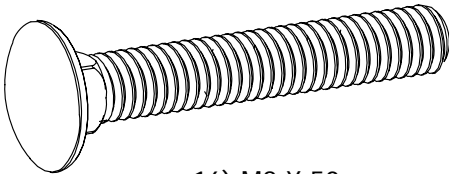

16) M8 X 50mm
Carriage Bolt

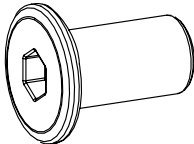

4) M6 Cap Nut

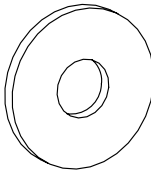

16) M6 Flat
Washer

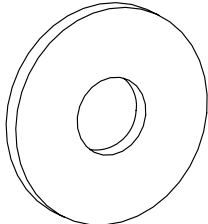

16) M8 Flat
Washer

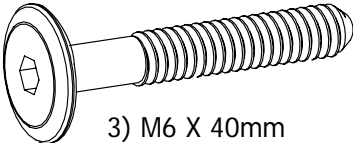

3) M6 X 40mm
Connector Bolt

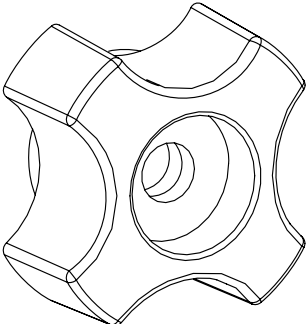

10) M8 Plastic
Knob

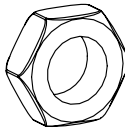

16) M8 Jam Nut

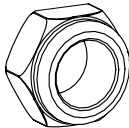

6) M8 Nylock
Nut

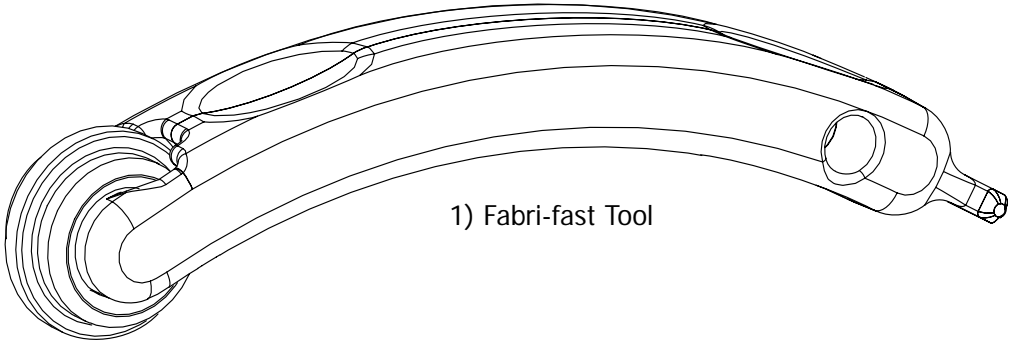

1) Fabri-fast Tool

Assembling the Grace EZ3 - Fabri-Fast Quilting Frame

Before You Begin

Using the parts list as a reference, take the parts out of the box and **make sure that you have them all.** (If there is something missing or broken, contact **The Grace Company** at **1-800-264-0644**. We will promptly ship any needed item.)

Tools needed

Please make sure that you have the following tools before assembling the frame. Once the frame is assembled, no tools will be needed for the use of the frame.

- One phillips head screw driver
- One 9/16", or 14mm open end wrench, or an adjustable wrench
- Two 4mm allen wrenches (*provided with hardware*)
- One 3mm allen wrench (*provided with hardware*)



Note: To help you distinguish wood parts, all left and right side parts are marked with an "L" or an "R" respectively, engraved into the wood on the inside of the part.

Step 1: Hardware to leg assembly

Parts needed:

- 6) M8 X 50mm carriage bolt
- 6) M8 jam nut
- 6) M6 flat washer
- 1) left leg
- 1) right leg

Fig. 1-1

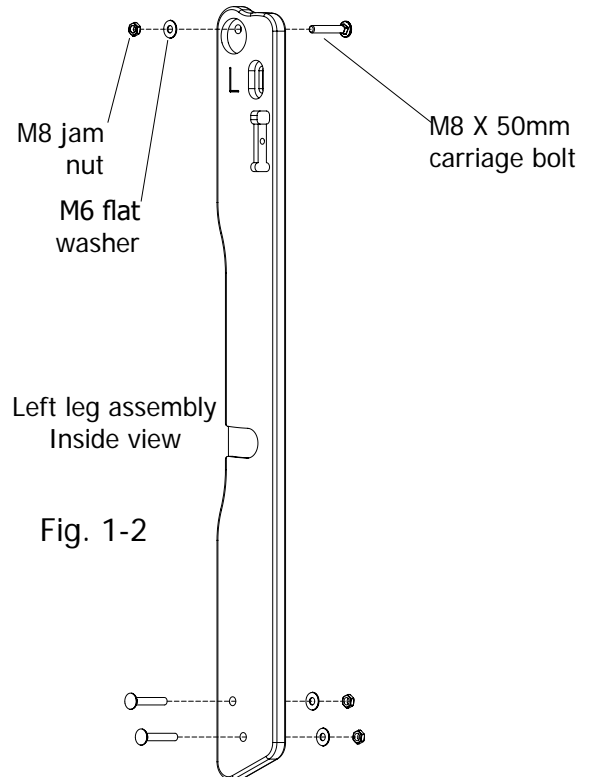
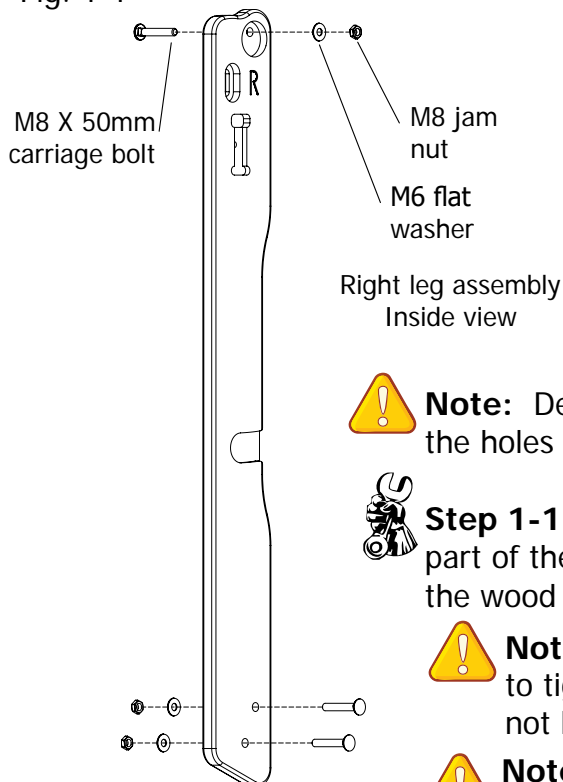

Note: Determine the direction that each carriage bolt goes through the holes in the legs.



Step 1-1: Tighten the jam nuts on the carriage bolt to pull the square part of the bolt into the wood until the bolt is completely seated into the wood part.



Note: You will need a 9/16" or a 14mm, or an adjustable wrench to tighten the M8 jam nuts. A wrench to tighten these nuts has not been provided with the frame.



Note: Failing to tighten the jam nuts in these initial steps will lead to assembly problems in further steps. Be sure to completely tighten each jam nut as instructed!

Step 2: Hardware to tilt head

Parts needed: 

- 6) M8 X 50mm carriage bolt
- 6) M8 jam nut
- 6) M6 flat washers
- 1) left tilt head
- 1) right tilt head

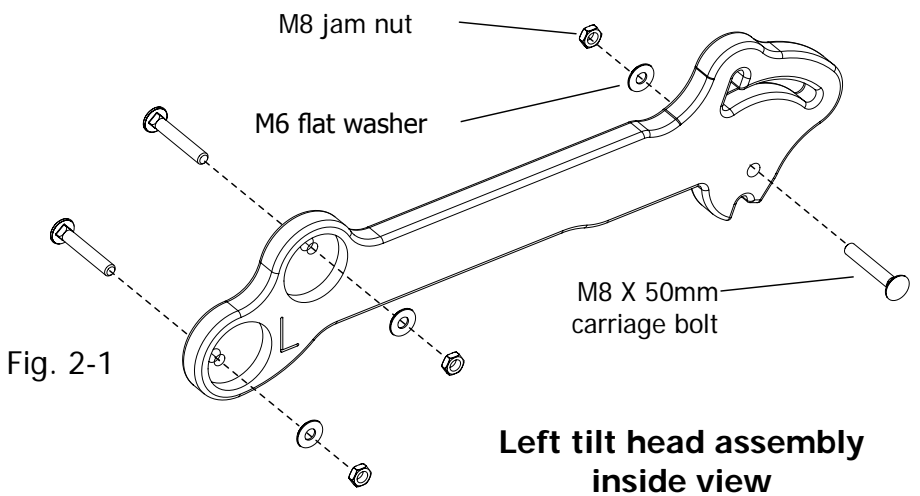

Note: Check which direction the carriage bolts are in relation to the tilt heads.



Step 2-1: Insert the carriage bolts through both tilt heads as shown in drawings. Tighten jam nuts over the end of each carriage bolt until the square part of the carriage bolt is completely seated into the wood.

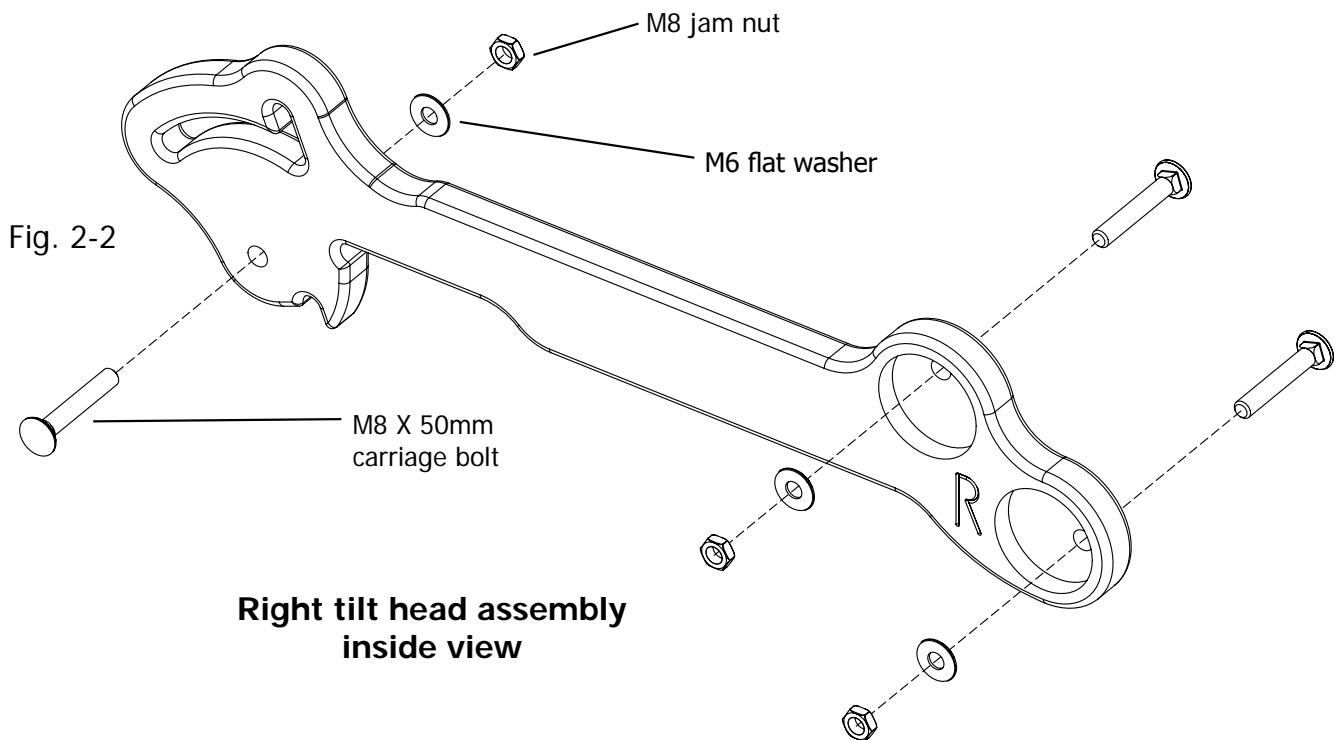



Step 3: Feet to leg assembly

Parts needed: 

- 2) M8 plastic knob
- 2) M8 nylock nut
- 4) M8 flat washer
- 1) right leg (with hardware installed)
- 1) left leg (with hardware installed)

 **Note:** The nylock nuts look just like jam nuts except for the thin white nylon ring inside. This keeps the nut from eventually working itself off of the bolt.

 When tightening nylock nuts at moveable points like this one, it is important not to over tighten!

 Use a wrench to tighten nylock nuts. You will notice that the nylock nut will not easily thread onto the bolt, because the nylon insert grabs the threads on the bolt.

 Tighten the nylock nut just enough to hold the washer loosely against the wood. You should be able to easily turn the washer with your finger.

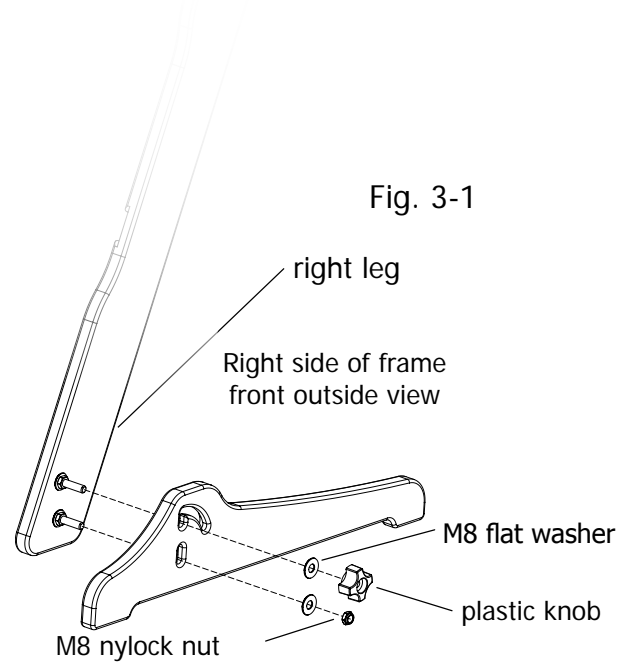

Fig. 3-1

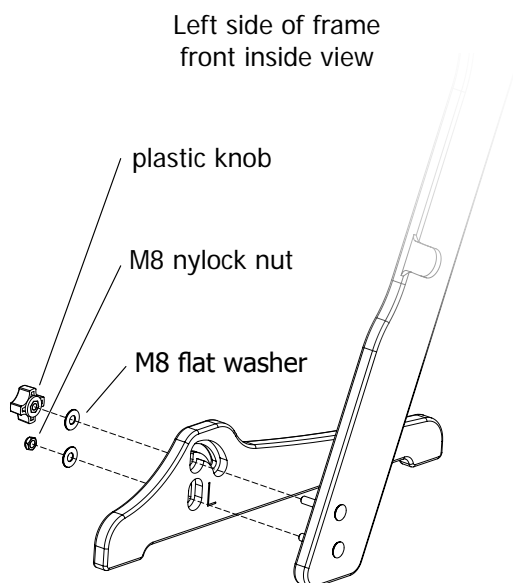



Fig. 3-2





Step 3-1: As shown in Fig. 3-1, and 3-2, place the carriage bolt ends through the holes in each foot.

 For ease of tightening, place flat washers and thread nylock nuts onto the carriage bolts closest to the bottom end of the leg first.

 The nylon side of nylock nuts faces out when threading onto the bolt end.

 **Note:** Leave all nylock nuts loose enough to slide the connected parts.

 **Step 3-2:** Next, thread the washers and plastic knobs onto the top most carriage bolts further from the end of the leg.

 **Step 3-3:** Build a right and left version of this assembly.

Step 4: Tilt head to legs assembly

Parts needed: 

- 2) M8 plastic knob
- 2) M8 nylock nut
- 4) M8 flat washer
- 2) leg assemblies
- 2) tilt heads (with hardware)

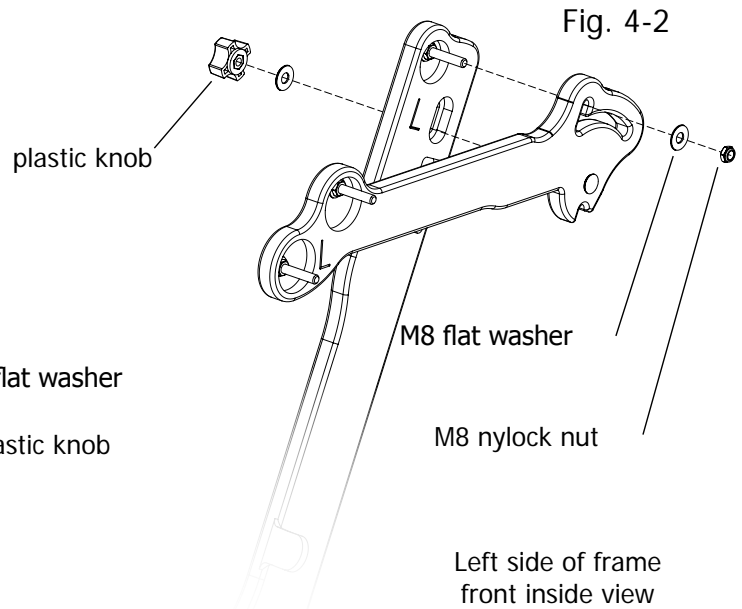
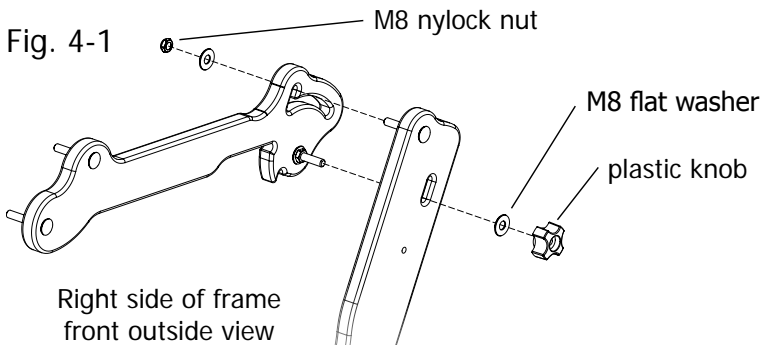

Step 4-1: Align the carriage bolts that are already installed on the tilt heads and place them through the holes in the legs as shown in Fig. 4-2.

Step 4-2: Place a flat washer and thread a plastic knob onto the end of the bottom carriage bolt (furthest from the end of the leg).

Step 4-3: Place a washer and thread a nylock nut loosely onto the carriage bolt closest to the end of the leg.

Do not tighten the nylock nuts all the way

Step 5: Rail mount end to tilt head/leg assembly

Parts needed: 

- 4) M8 flat washer
- 2) M8 plastic knob
- 2) M8 nylock nut
- 1) left rail mount end
- 1) right rail mount end (pre-installed threaded inserts)

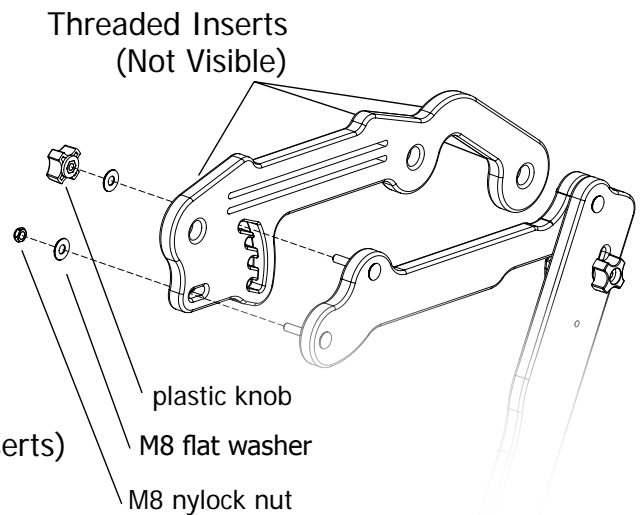
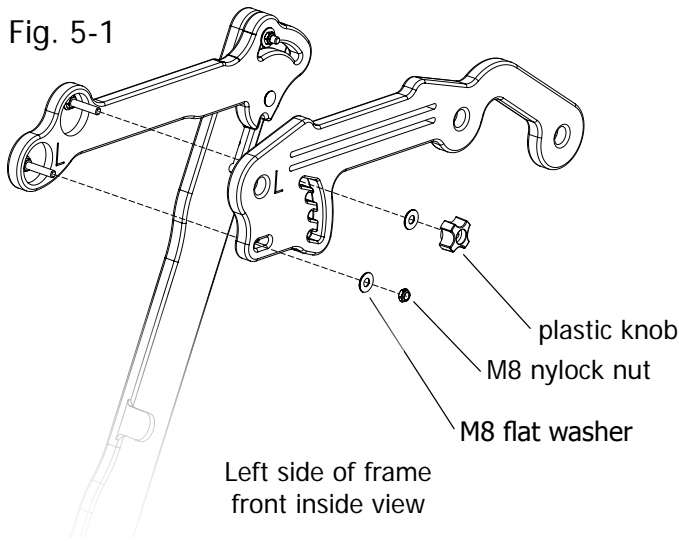

Fig. 4-3

Fig. 5-1



Step 5-1: Fasten the left rail mount end to the left tilt head/leg assembly by placing the two carriage bolts through the rail mount end (as shown in Fig. 5-1).

⚙️ **Step 5-2:** Place a flat washer and thread a plastic knob onto the top most carriage bolt (furthest from the end) of the tilt head

⚙️ **Step 5-3:** Place a flat washer, and thread a nylock nut onto the carriage bolt closest to the end of the tilt head.



NOTE: Do not over-tighten nylock nuts! The washer must be able to spin freely.

How large does your quilting frame need to be? The EZ3 can be built in 3 sizes!



Determine how large you would like your quilting frame to be. The EZ3 can be built in the following 3 sizes, (32 inch, 64 inch, and 96 inch). Build your quilting frame in the size that most closely reflects the size of quilts that you will be making the most often. The quilting frame can easily be re-sized at a later time if your frame size requirements change.

Step 6: Hardware to brace assembly

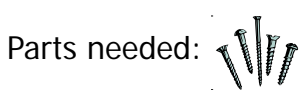

(Build 2 side brace assemblies)

Parts needed:

- 2) M8 X 50mm carriage bolt
- 2) M6 flat washer
- 2) M8 jam nut
- 2) side brace

Fig. 6-1

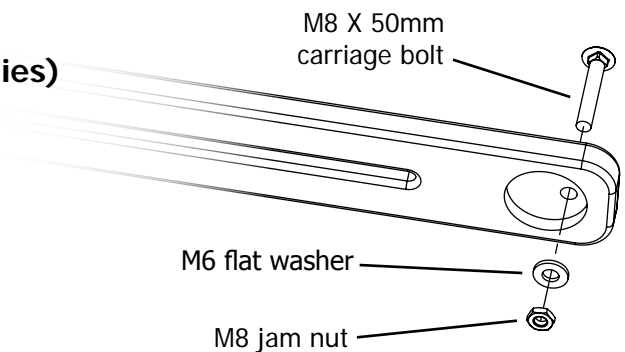

Step 6-1: Thread one M8 X 50mm carriage bolt through the end of each side brace section as shown in Fig. 6-1.

⚙️ **Step 6-2:** Place each of the M6 washers and also the M8 jam nuts onto each carriage bolt as shown. Tighten the jam nut all the way so that the square part on the carriage bolt is drawn completely into the wood.



Assemble braces based on your frame size requirements. If you are building the 36 inch frame, complete step 7, otherwise skip to step 8.

Step 7: 36 inch brace assembly

Parts needed:

- 2) M8 plastic knob
- 2) M8 washer
- 2) side brace (with hardware)

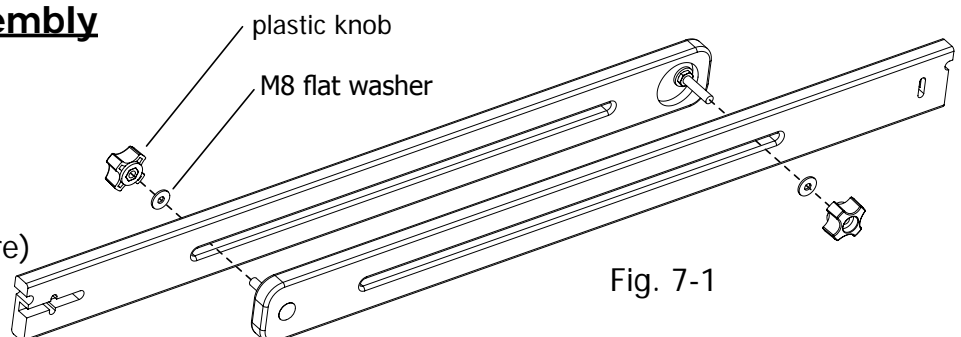



Fig. 7-1

(Mini size: for display, or small projects)





Step 7: Insert the just installed bolts through the slot located in the other side brace as shown in Fig. 7-1. Secure the braces together using M8 washers and plastic knobs.

Step 8: Middle brace assembly

Parts needed: 

- 2) M6 x 30mm connector bolt
- 2) M6 cap nut
- 2) M8 X 50mm carriage bolt
- 2) M6 flat washer
- 2) M8 jam nut
- 2) middle brace

 **Step 8-1:** Insert a carriage bolt through the end of each middle brace. Secure the carriage bolt in place using a flat washer, and a jam nut (exactly as done in step 6).

 **Step 8-2:** Bolt the middle braces together by first inserting a cap nut through the hole furthest from the end of each middle brace. Now insert a M6 X 30mm connector bolt through the hole closest to the end of both of the braces, and secure tightly into the cap nut.

 **Note:** Make sure that the cupped out ends of the braces are facing as shown in Fig. 8-1.

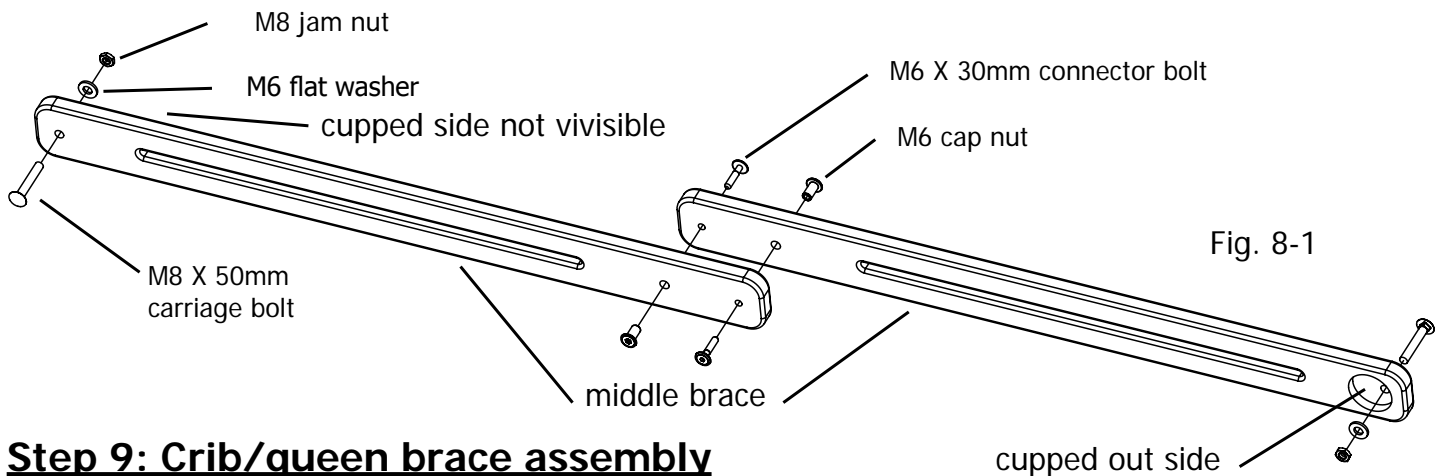



Step 9: Crib/queen brace assembly

Parts needed: 

- 4) M8 flat washers
- 2) M8 plastic knobs
- 2) side braces (with previously installed hardware)
- 1) middle brace assembly

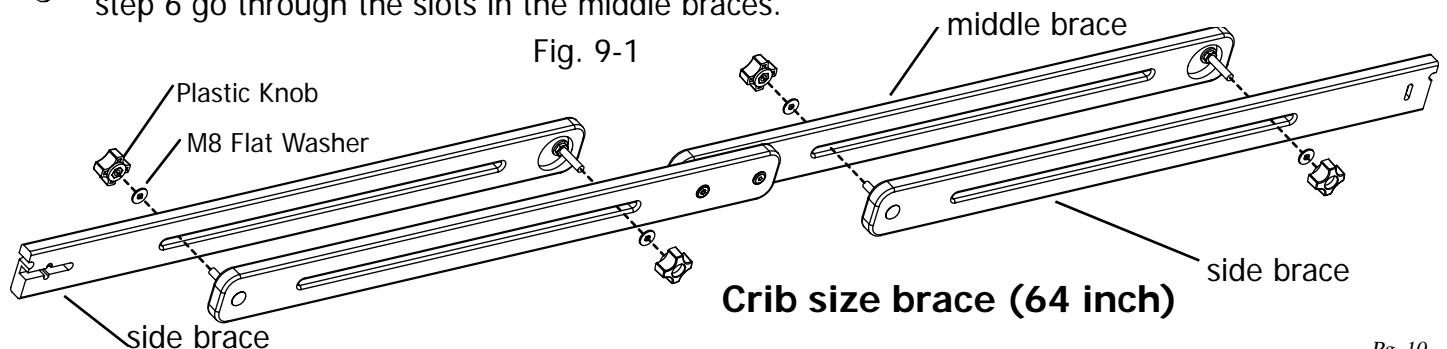
 **Step 9-1:** Align the braces as shown in Fig. 9-1 below, so that the carriage bolts installed in step 6 go through the slots in the middle braces.



 Leave brace knobs slightly loose, so that it is easier to adjust the frame to your rail size later.

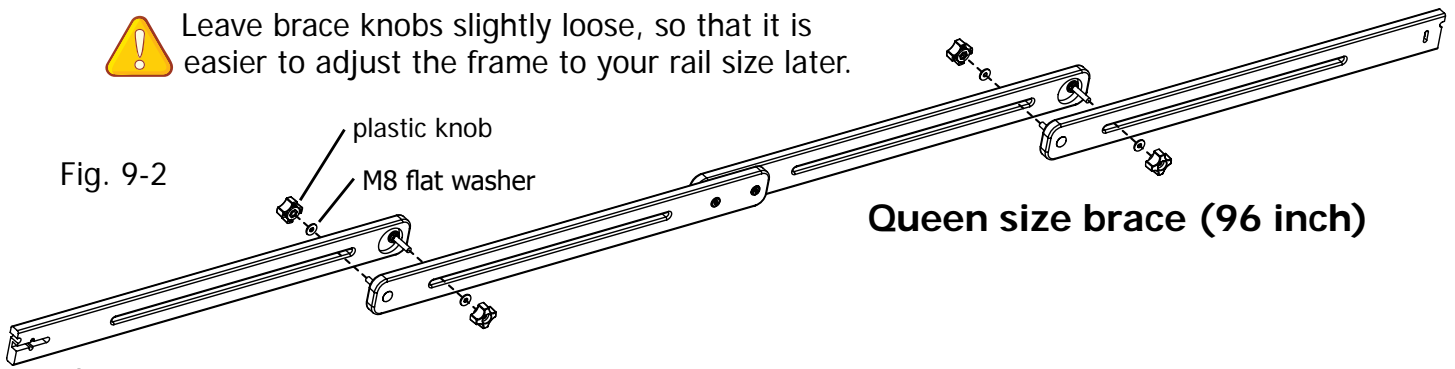

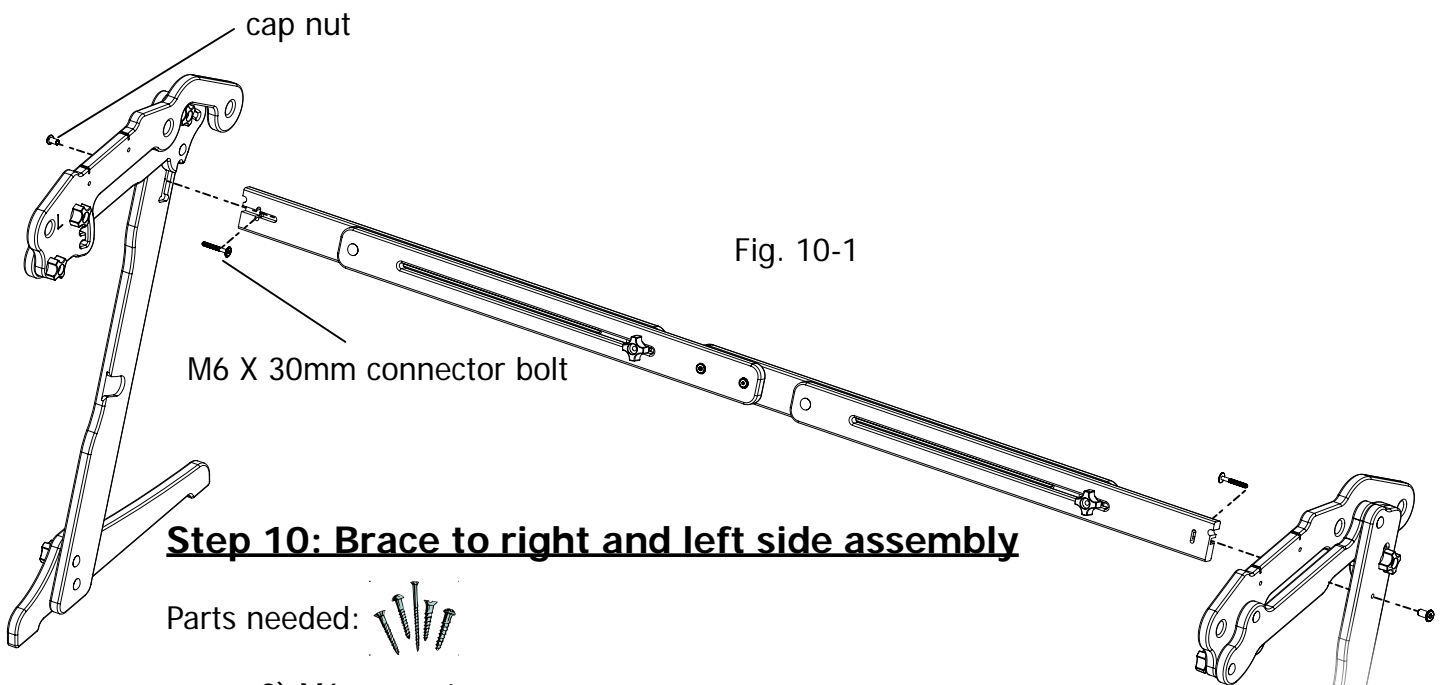

 **Step 9-2:** Place the M8 flat washers onto the bolt and thread on the plastic knobs for each side of the brace, as shown in Fig. 9-2.

 **Note:** No additional pieces are needed to extend the brace from the crib size to the queen size. You can lengthen or shorten the brace by loosening the plastic knob and sliding the braces to the desired position.



- 2) M6 cap nut
- 2) M6 X 30mm connector bolts
- 2) assemblies for right and left sides
- 1) completed brace assembly from Step 8

 **Step 10-1:** Line the notched brace up with the notched hole on the left leg.

 **Note:** Standing at the front of the frame, the brace attached to the left side should be the rear of the two pieces included in the brace assembly.

 **Note:** The notch should be up!

 **Step 10-2:** Place the connector bolt into the slot as shown.

 **Step 10-3:** Slide the cap nut into the hole as shown in Fig. 10-1, and start threading it into the connector bolt.

⚙️ **Step 10-4:** Using your allen wrench completely tighten the bolt.

⚙️ **Step 10-5:** Repeat the process for the right side assembly.

Step 11: Ratchet wheels and rail assembly

Parts needed: 

(Build 3 complete rails)

- 3) ratchet wheel
- 3) round end cap
- 6) M5 square nut (Pre-Installed)
- 3) 32" rail (mini)

6) M5 X 10mm screw (mini)
6) 32" rail (crib)
12) M5 X 10mm screw (crib)
3) rail coupler (crib)
9) 32" rail (queen)
18) M5 X 10mm screw (queen)
6) rail coupler (queen)

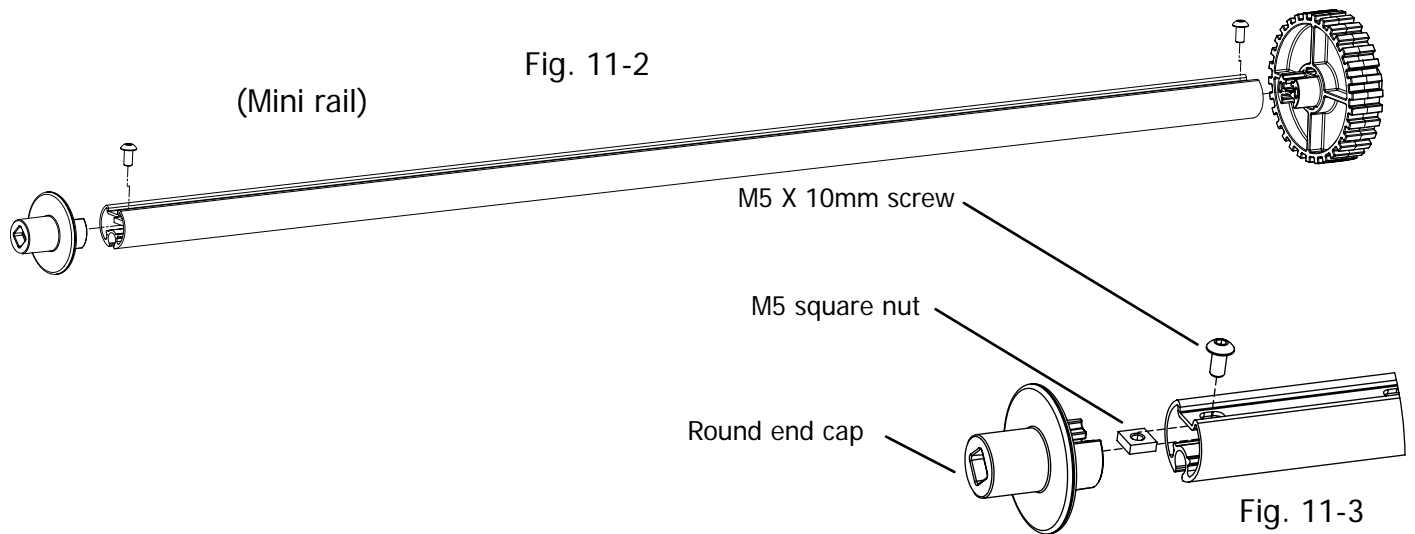
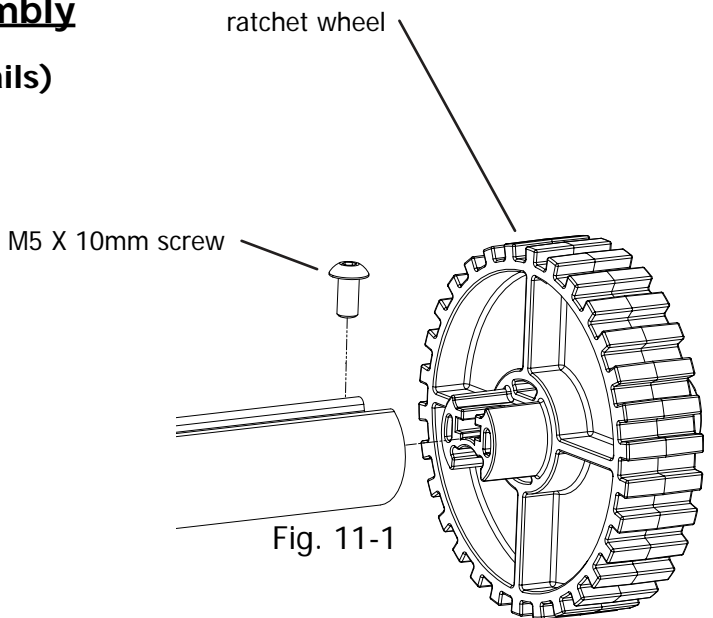

Round end cap

 **Step 11-1:** To assemble the 32" assembly you will need to attach a ratchet end cap to one end, and a round end cap to the other end of a 32" no sag rail.

⚠️ **Note:** For the 64" and 96" rail assemblies attach a ratchet end cap to one end of 3 rails, then go to step 11-7.

⚙️ **Step 11-2:** Insert a M5 square nut into the slot in each end cap (all round and ratchet end caps), as shown.

⚙️ **Step 11-3:** Insert the ratchet end cap into the rail and then screw in a M5 screw. Tighten the screws securely using the provided 3mm allen wrench. (If building the mini frame go to Step 11-9).

⚙️ **Step 11-4:** For the crib size (64") assembly, connect two 32" rails using rail couplers. Position one end of the coupler inside the end of a rail as shown in Fig. 11-4.

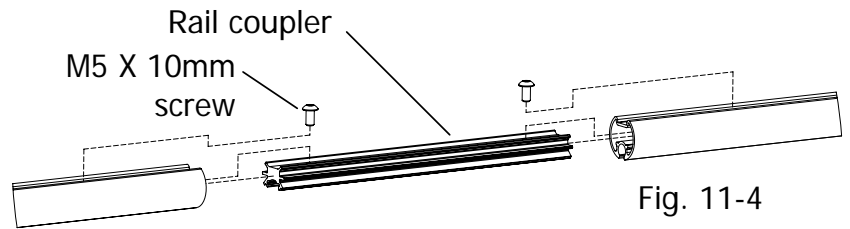

⚠️ **Note:** Use one rail with a ratchet end cap (already installed), and one rail with nothing currently attached for each crib size rail.

⚙️ **Step 11-5:** Secure the rail to the coupler by inserting a M5 x 10mm socket head screw into the **second hole from the end of the rail**. Line up the hole in the rail with the hole in the end of coupler.

⚠️ **Note:** Before tightening the M5 screw completely, attach another rail to the exposed end of the rail coupler, using an M5 screw.

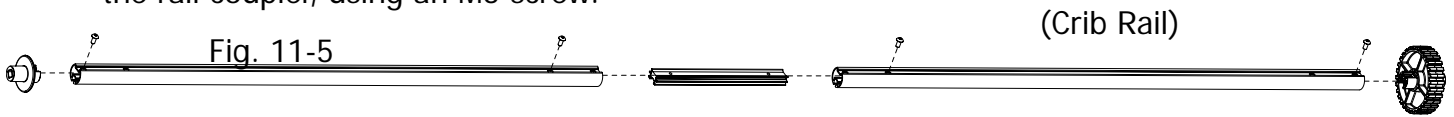

⚙️ **Step 11-6:** The two 32" rails should be snug against each other, completely covering the coupler. Tighten the screws completely, using the 3mm allen wrench.

⚙️ **Step 11-7:** Attach a round end cap to the open end of each of the 64" rails using a socket head screw. Thread the screw completely into the square nut installed in the end cap. Tighten the screws completely, using the 3mm allen wrench.

⚙️ **Step 11-8:** For the queen size rail assembly (96"), connect three of the 32" rails together using 2 rail couplers per rail.

⚠️ **Note:** Build 3 complete rail assemblies. If the assembly you built leaves you with extra rails (32", and 64" rail assemblies) save them, with the additional hardware for future use.

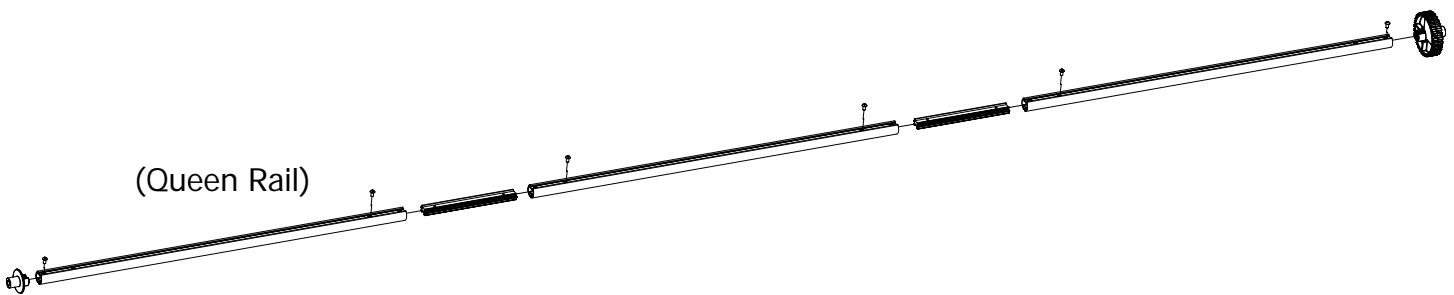

Step 12: Rail to frame assembly

Parts needed:



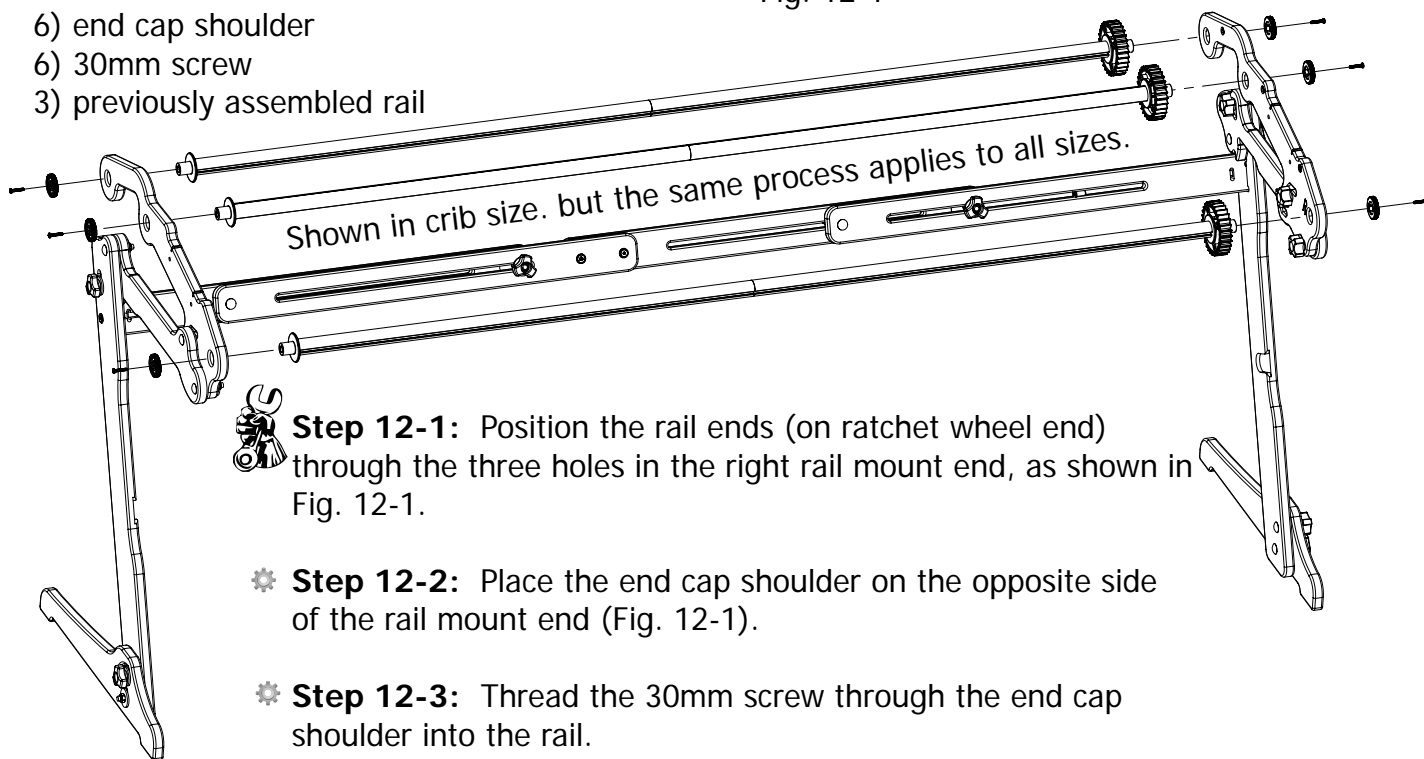

- 6) end cap shoulder
- 6) 30mm screw
- 3) previously assembled rail

Fig. 12-1



 **Step 12-1:** Position the rail ends (on ratchet wheel end) through the three holes in the right rail mount end, as shown in Fig. 12-1.

 **Step 12-2:** Place the end cap shoulder on the opposite side of the rail mount end (Fig. 12-1).

 **Step 12-3:** Thread the 30mm screw through the end cap shoulder into the rail.

 **Step 12-4:** Repeat this process on the left rail mount end.

Step 13: Ratchet stop assembly

Parts needed:



- 3) ratchet stop
- 3) M6 X 40mm connector bolt



Step 13: Insert the connector bolt through the ratchet stops, and thread into the holes on the rail mount end as shown in Fig. 13-1.



Finger tighten only!

ratchet stop
M6 X 40mm Connector bolt

Fig. 13-1

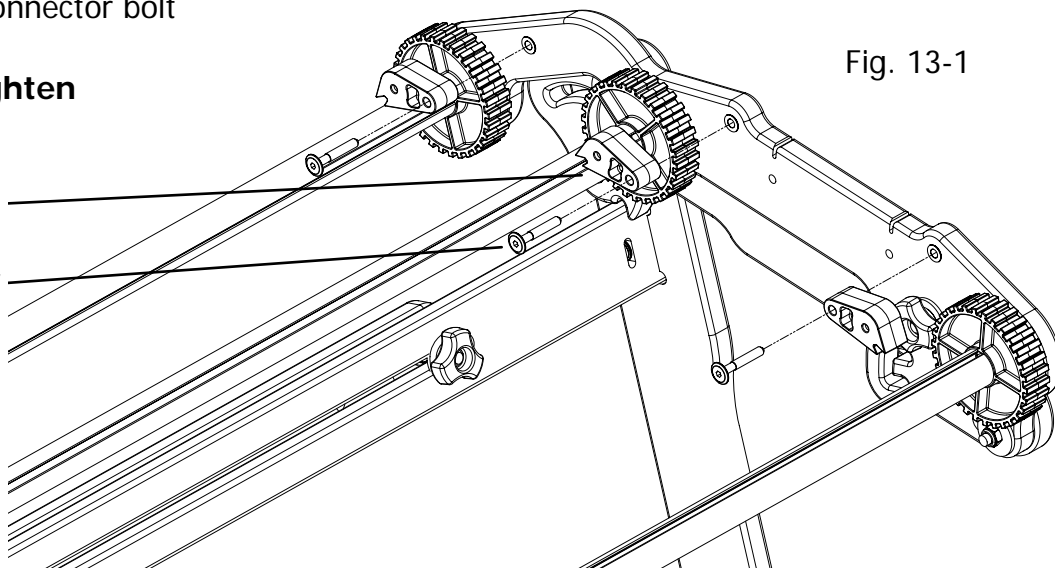

You are now finished with the assembly of your EZ3 Fabri-Fast quilting frame!!!

Assembly & use of accessories

(Available from the Grace Company: 1-800-264-0644 www.graceframe.com)

Application and use of bungee clamps

The bungee clamps help keep even tension on the outside edges of your quilt work area. First put the bungee clamp inside the frame end. Thread the cord through the hole on the inside of the frame rail mount end. Pull the bungee cord down into the slot.

You will then want to attach the clamp to your fabric.

NOTE: Very little tension is recommended while quilting.

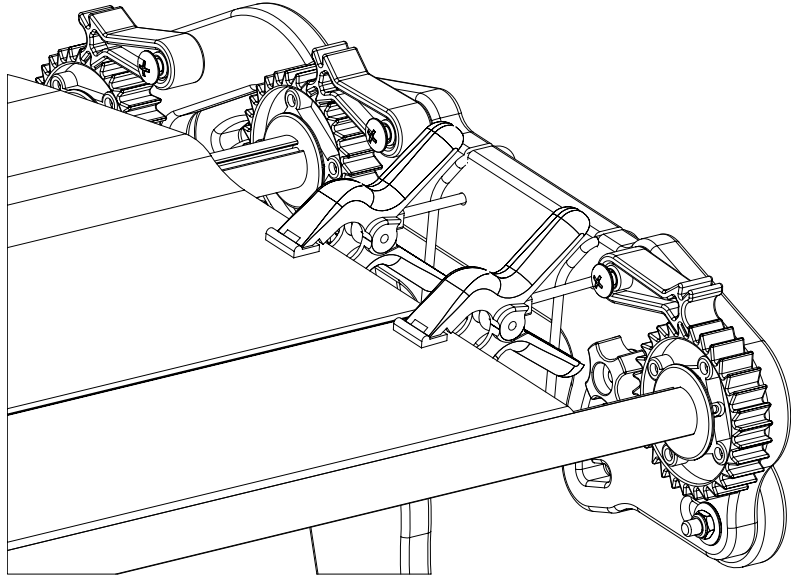

Tilting the EZ3 fabri-fast

The following is done best one side at a time.

- ⚙ **Step 1:** Loosen knob inside front on both ends of the frame, as show in Fig. 14-1.
- ⚙ **Step 2:** Standing at back of the frame slide rail assembly forward slightly.

Fig. 14-1

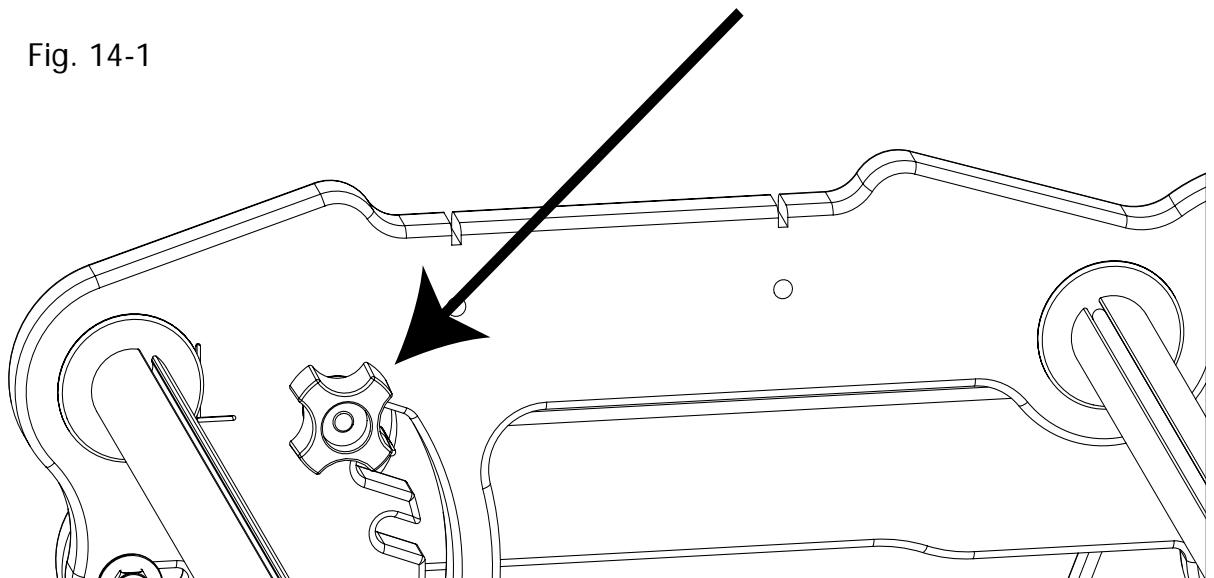

- ⚙ **Step 3:** Tilt the frame to desired angle between 0 and 45° degrees.
- ⚙ **Step 4:** Tilt rail assembly back until both ends rest solid between notch in tilt arch.
- ⚙ **Step 5:** Retighten knobs inside front on both ends of frame.

Folding the EZ3 fabri-fast



- Frame must not be tilted when it is to be folded, as show in Fig. 15-1
- Folding feature will not affect the quilt in progress.
- Folded frame is about 6-1/2" wide.
- Follow the steps in order, without variation.
- Reverse steps to unfold.

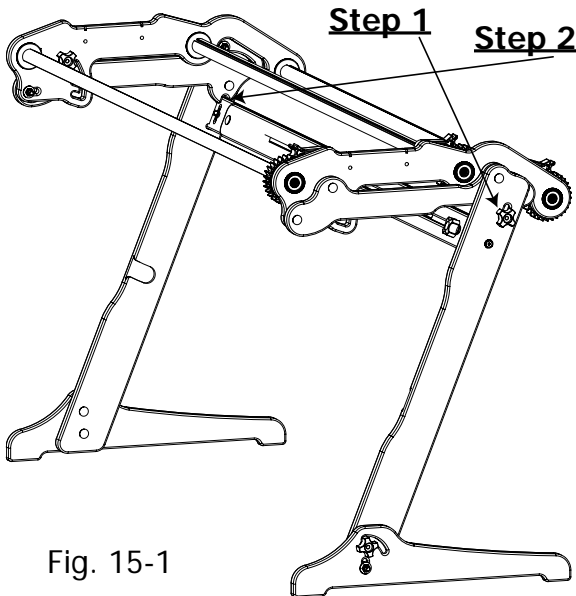

Fig. 15-1

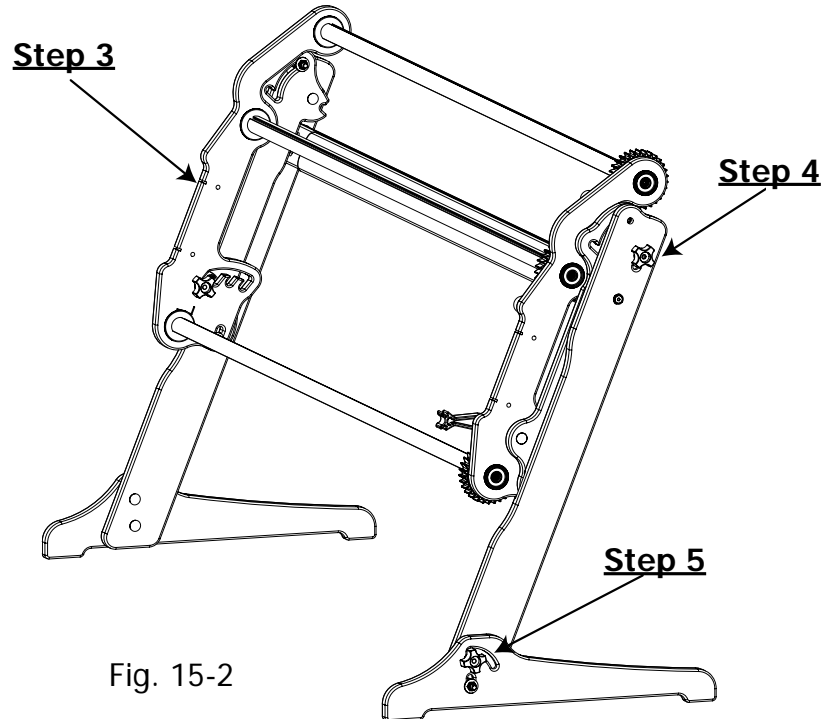

Fig. 15-2

- ⚙ **Step 1:** Loosen knobs outside on both sides of frame. (As seen in Fig. 15-1)
- ⚙ **Step 2:** Lift at joint until top releases. (As seen in Fig. 15-1)
- ⚙ **Step 3:** Top rail section pivots down. (As seen in Fig. 15-2)
- ⚙ **Step 4:** Retighten knobs outside on both ends of frame. (As seen in Fig. 15-2)
- ⚙ **Step 5:** Loosen knobs outside base legs on both sides of frame. (As seen in Fig 15-2)
- ⚙ **Step 6:** Lift entire frame from the brace until legs drop to the joint.
- ⚙ **Step 7:** Frame will rotate forward and down.
- ⚙ **Step 8:** Gently lay frame flat.
- ⚙ **Step 9:** Retighten knobs on base legs. (As seen in Fig. 15-3)

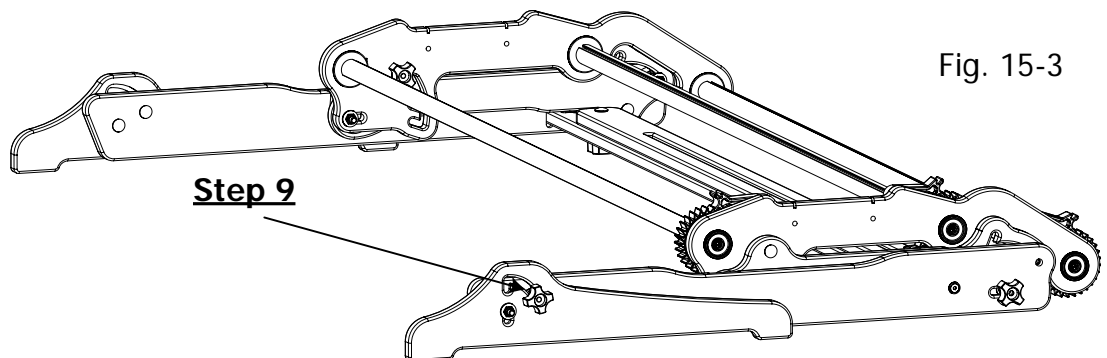

Fig. 15-3

Quilting on the EZ3-FF

Table of Contents

Preparing the fabric layers for installation	17
Fabric installation	17
Method #1: Preparing and using The Grace Company Optional StartRight™ cloth leaders	17
Method #2: Making and using (DIY) cloth leaders	19
Applying quilt fabric to cloth leader	20
Method #3: Installing the fabric directly to the rails.	23
Troubleshooting	24
Tips for tying quilts	24

Preparing the fabric layers for installation

Make sure that each layer of fabric is the correct size and has straight edges and square corners.

The short time and small amount of effort that you spend measuring and squaring your quilt will result in better results throughout the quilting process.

If the lining or backing has a seam running down the middle be sure to cut the selvedge off at the seam and press the seam open over its entire length.

Bonded batting is highly recommended.



Please read the following installation methods completely before choosing your method and proceeding!

The use of cloth leaders is highly recommended, and is the preferred method for installing your fabric. The use of leaders is especially recommended when quilting a pieced top or a backing made with multiple pieces. Though it will take a little more time in the initial setup, it will quickly become a huge time-saver, preventing you from having to detach and re-attach your quilts as each one nears completion.

Fabric installation

Method #1: Preparing and using The Grace Company Optional StartRight™ cloth leaders

The Grace Company StartRight™ leaders are an accessory available from [The Grace Company](http://TheGraceCompany.com). The Grace Company StartRight™ leaders have many features that simply are not available with any other products. Please visit www.graceframe.com for complete product information.

Step 1:

Cut leaders to length

Cut your cloth leaders to size, determined by the length of your quilting frame: mini 26" cloth leader, crib 58" cloth leader, and queen 90" cloth leader.

Step 2:

Determine which leader goes on each rail

Install the widest leader to the back rail. The middle sized leader gets attached to the middle rail. Install the narrowest leader to the front rail.

Step 3:

Installing leaders into your frame

Option 1: Velcro® Method

Attach the leaders to your rails by first laying down sticky-backed Velcro® to each rail (*be careful to not cover the Fabri-Fast slot in the rail with the velcro*). Lay the Velcro® side of the leaders over the Velcro® previously installed on the rail.

Option 2: Fabri-Fast™ Method

This method works on all Grace Frames™ with Fabri-Fast rails. First, locate the Fabri-Fast™ Guide Line on your printed leader cloth. Line up the guide line over the slot of your Fabri-Fast™ rail. Insert the leader cloth, and Fabri-Fast tubing into the Fabri-Fast slot using the Fabri-Fast tool (See Fig. 16-4)

Step 4:

Applying your fabric to the leaders

(Here are two options for fabric attachment, although there are other ways)

First, locate and mark the center of each of your quilt layers.

Attach each quilt layer to its respective leader starting in the center of the fabric, then working out to each edge. Line the edge of your fabric layer with the edge of your leader.

Note: Attach the quilt backing to the leader so the finished side of the fabric is face-down. Attach the quilt top with the finished side face-up.

Option 1

Staple Method

Adjust the reference tool on the top of your stapler so that you staple 1/2" in from the fabric edges.

Before stapling fabric sew a small piece of scrap fabric to the edge of your quilt fabric, that can easily be removed when you are finished sewing your quilt on the frame.

Place your staples through this piece of temporary fabric, and into the leader cloths.

By adding a scrap piece of fabric to the edges your quilt, the quilt fabric will not be damaged by the staples.

Option 2:

Pinning Method

Line the edge of your fabric layer with the edge of your leader. Pin the edges together working from the center out.

NOTE: Do not stretch your fabric as you attach it to your leader cloths. This will cause your quilt layers to roll unevenly onto your frame. As you attach your fabric, let it lay as naturally as possible.

Note: After you decide which attachment method you prefer, go to page 20 and read "Attaching fabric to cloth leader."

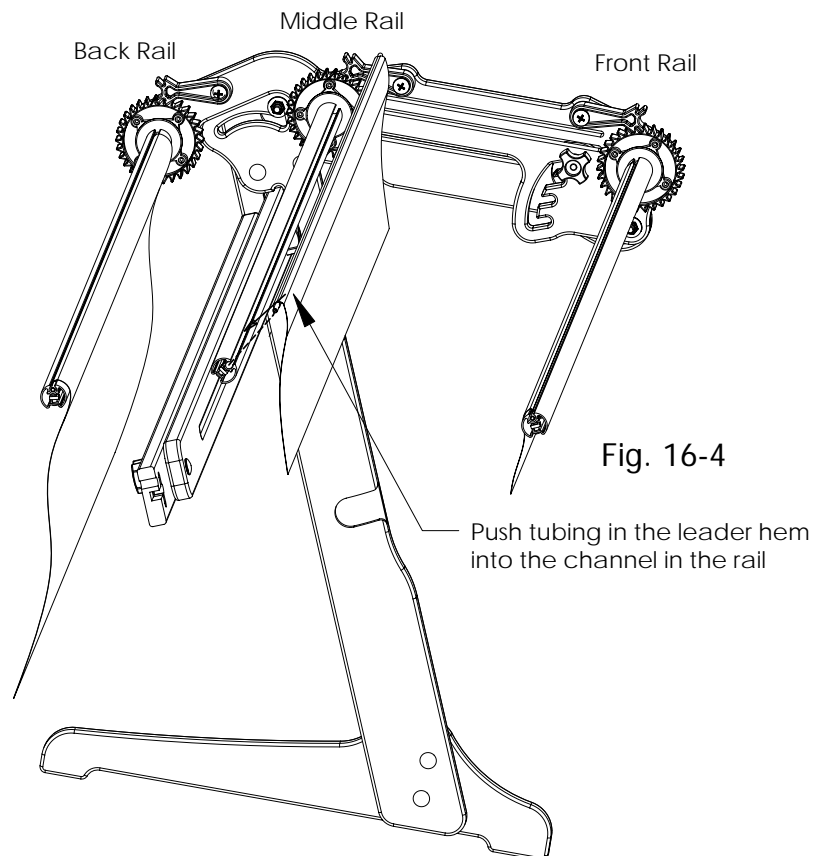
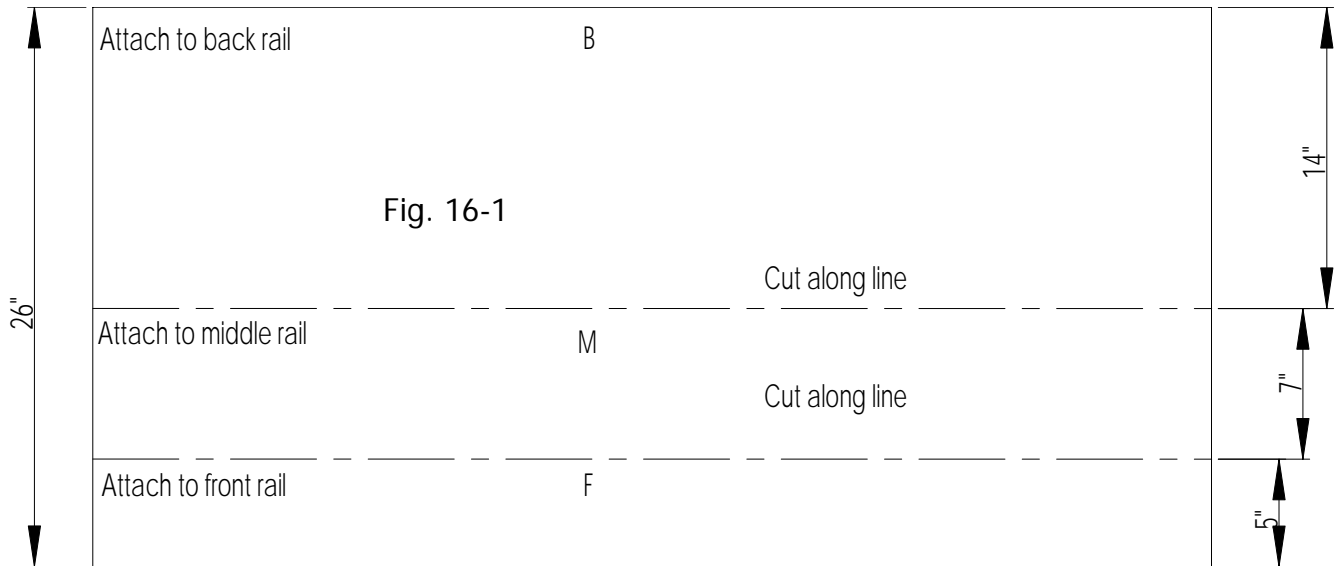

Fig. 16-4

Method #2: Making and using cloth leaders

Step 1: The cloth size is determined by the length of your quilting frame: mini 26" cloth leader, crib 58" cloth leader, and queen 90" cloth leader, as shown in Fig. 16-1.



Cut your material to the dimensions specified above. Pieces "B", "M", and "F" correspond to the fabric for the back, middle, and front rails.

Step 2: Sew a hem along an edge of each leader cloth, as shown in Fig. 16-2.

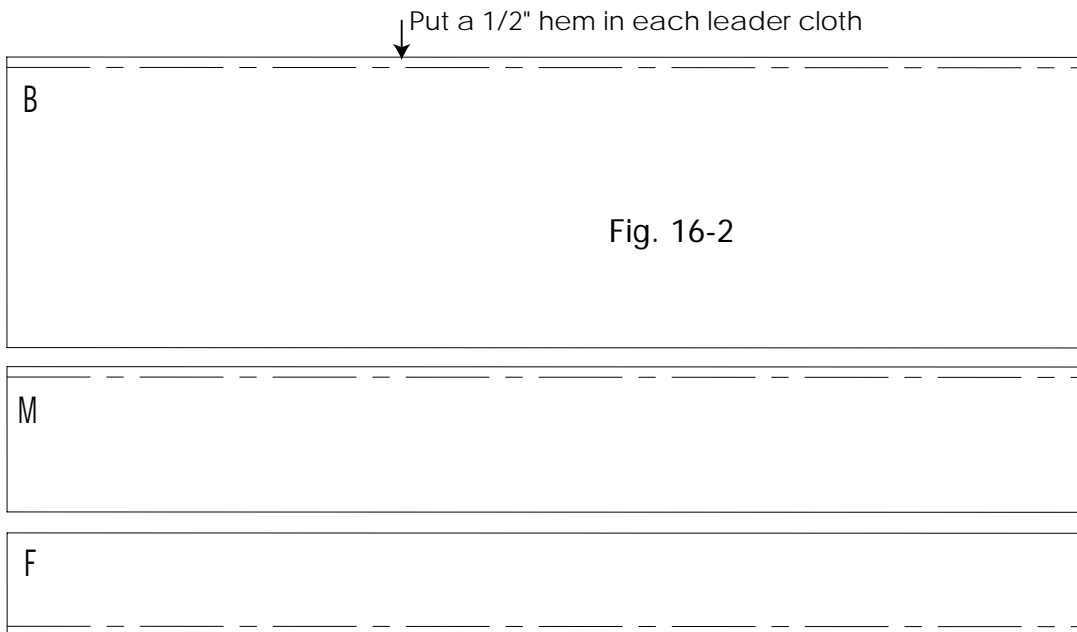

Step 3: Slide the plastic "Fabri-Fast" tubing into this hem or casing, as shown in Fig. 16-3.

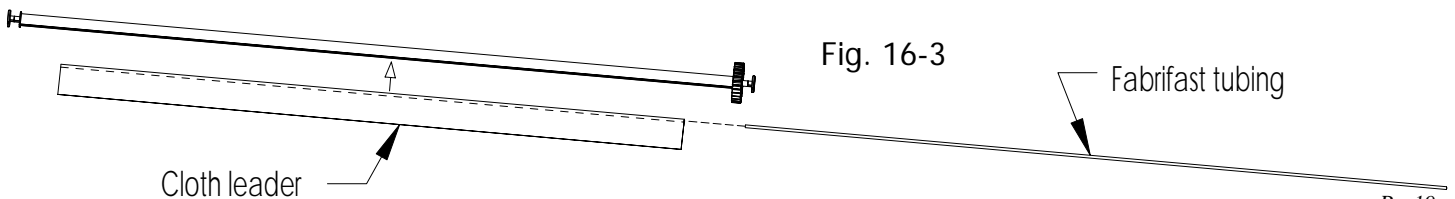

Alternative method: Instead of making a hem or casing, you may also draw or sew a straight line in your fabric, 1/2" from the edge of the leader cloth. Use this line as a guide to line up your fabric retaining tube.

Now push your tubing with fabric into the slot of the corresponding rail using the fabri-fast tool. Insert the 14" leader into the back rail, the 7" leader to the middle, and the 5" to the front.

Now you are ready to install your fabric layers to the quilting frame, attaching each layer to the corresponding cloth leader.

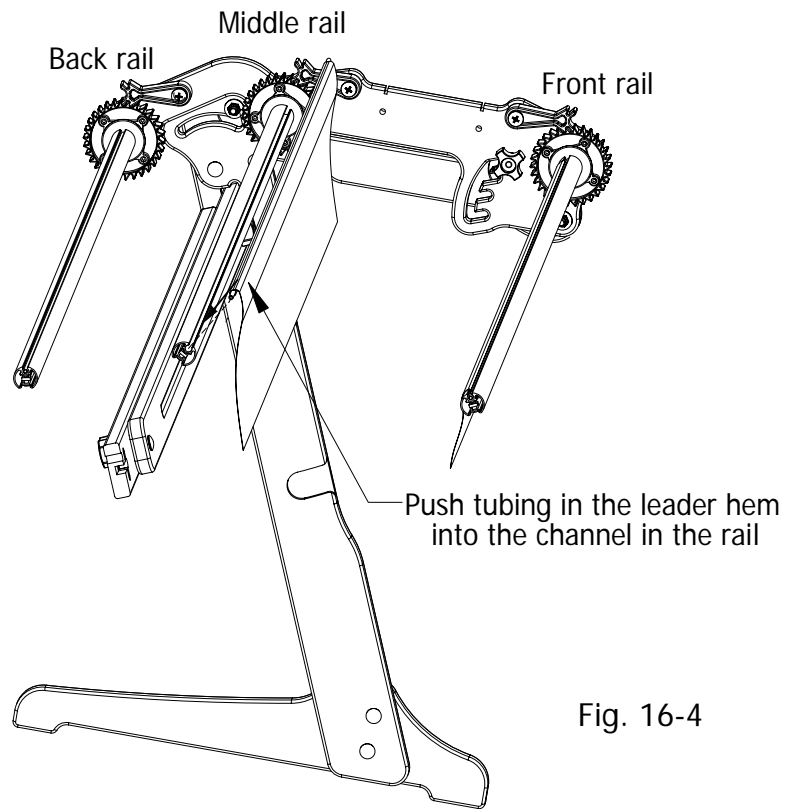

Fig. 16-4

Applying quilt fabric to cloth leader

A. Backing fabric

- **Proper sizing:** The first fabric that will be applied to the quilting frame is the backing. The backing is also known as the lining fabric. This piece of fabric will be the under side of the finished quilt. It is recommended that this piece of fabric be larger than the top, on all four sides, especially if your top is a pieced top. (A pieced top may stretch out and become larger than the backing if you do not make this allowance). The backing fabric can be one continuous piece of fabric or can be made by sewing fabric together.

- **Piecing the backing fabric:** Many quilts have back fabrics that are not one continuous piece of fabric and are pieced together using two fabric pieces with a seam down the middle or three fabric pieces with two seams having been sewn. Cut the selvedge off before you piece the back fabric together. The selvedge is woven more tightly than the rest of the fabric and won't have the same give as the rest of the fabric. This may cause the seam to be too tight. Use a slightly larger, looser machine stitch than normal in sewing/piecing the lengths of the back fabric together. You also can sew your back fabrics together using crosswise piecing.

Step 1: Backing fabric to middle rail: Mark the center of backing fabric with a pin or pencil mark. Place the center mark to the center of the middle rail. (The backing fabric is put on with the wrong side of the fabric up and visible.)

Lay the fabric naturally and evenly along the straight line of the cloth leader. Do not stretch the fabric from side to side. Start pinning the fabric onto the leader along the line that has been stitched or marked, as shown in Fig. 16.5.

Note: Flat flower pins work great for this, and roll well against the rail.

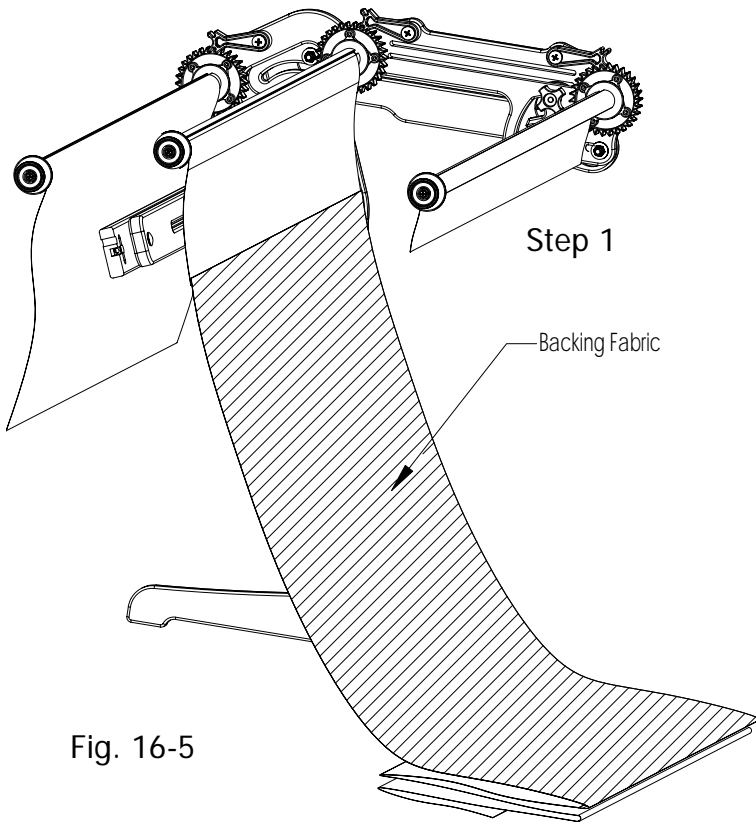

Fig. 16-5

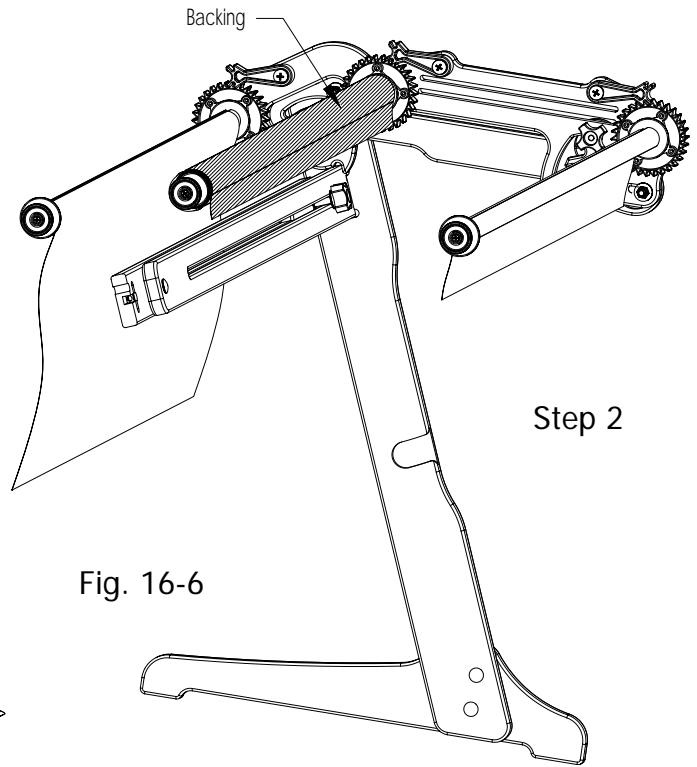

Fig. 16-6

Step 2: Rolling fabric onto middle rail: Next, roll the quilt backing onto the middle rail. To do this properly, be sure to roll the rail counter-clockwise as you look at the frame (toward the ratchet wheels). The fabric needs to roll from off the top of the rail and toward the front rail, as shown in Fig. 16-6.

Roll the material onto the middle rail, making a smooth roll. Be sure that no wrinkles are present.

Smooth the quilt from the center to the outside edges of the rail as it is being rolled. At this point do not roll the fabric tightly, just nicely smooth and even.

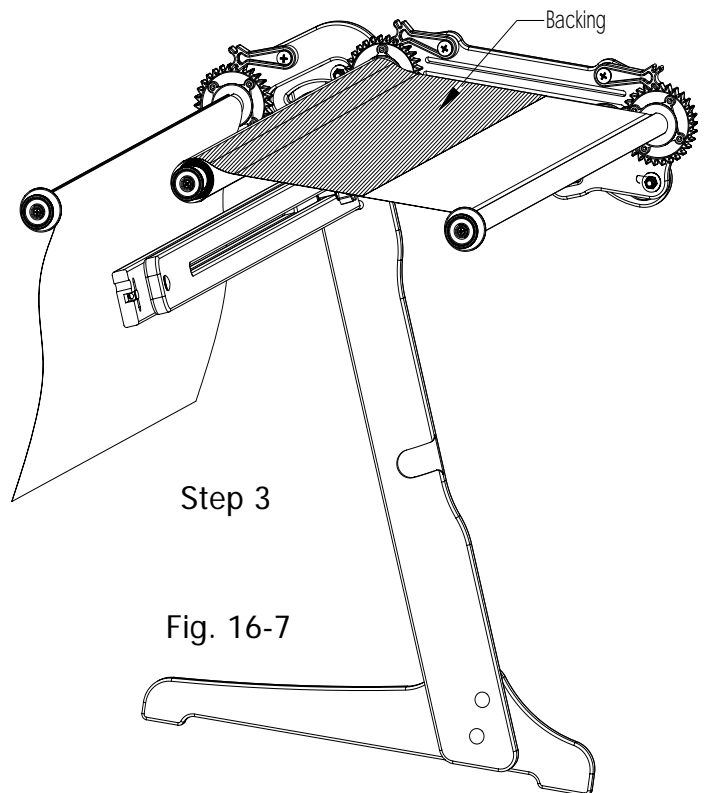

Fig. 16-7

Step 3: Opposite end of backing fabric to front rail: Place the other end of the backing fabric to the front quilting rail cloth leader, centering with the mark as directed on the front rail (the same way as the middle rail).

Place the center mark of the backing to the center of the front rail leader. Lay the fabric naturally and evenly along the straight line of the leader cloth. Do not stretch the fabric. Pin the fabric to the cloth leader, as shown in Fig. 16-7.

Make sure that the amount of rail showing at the edges of the fabric to the end boards is the same on all rails.

Note: The fabric should never be tight when attaching it to your frame. For best results, use as little tension as possible without letting the quilt sag.

B. Batting and Quilt Top

Lay the quilt top face down on the floor and line your batting directly over it. Mark the center of the top and batting.

Line up the edge of the quilt top/batting to back rail cloth leader as shown in Fig. 16-8. Line the center the top/batting to the center of the rear rail. Pin fabric to the cloth leader.

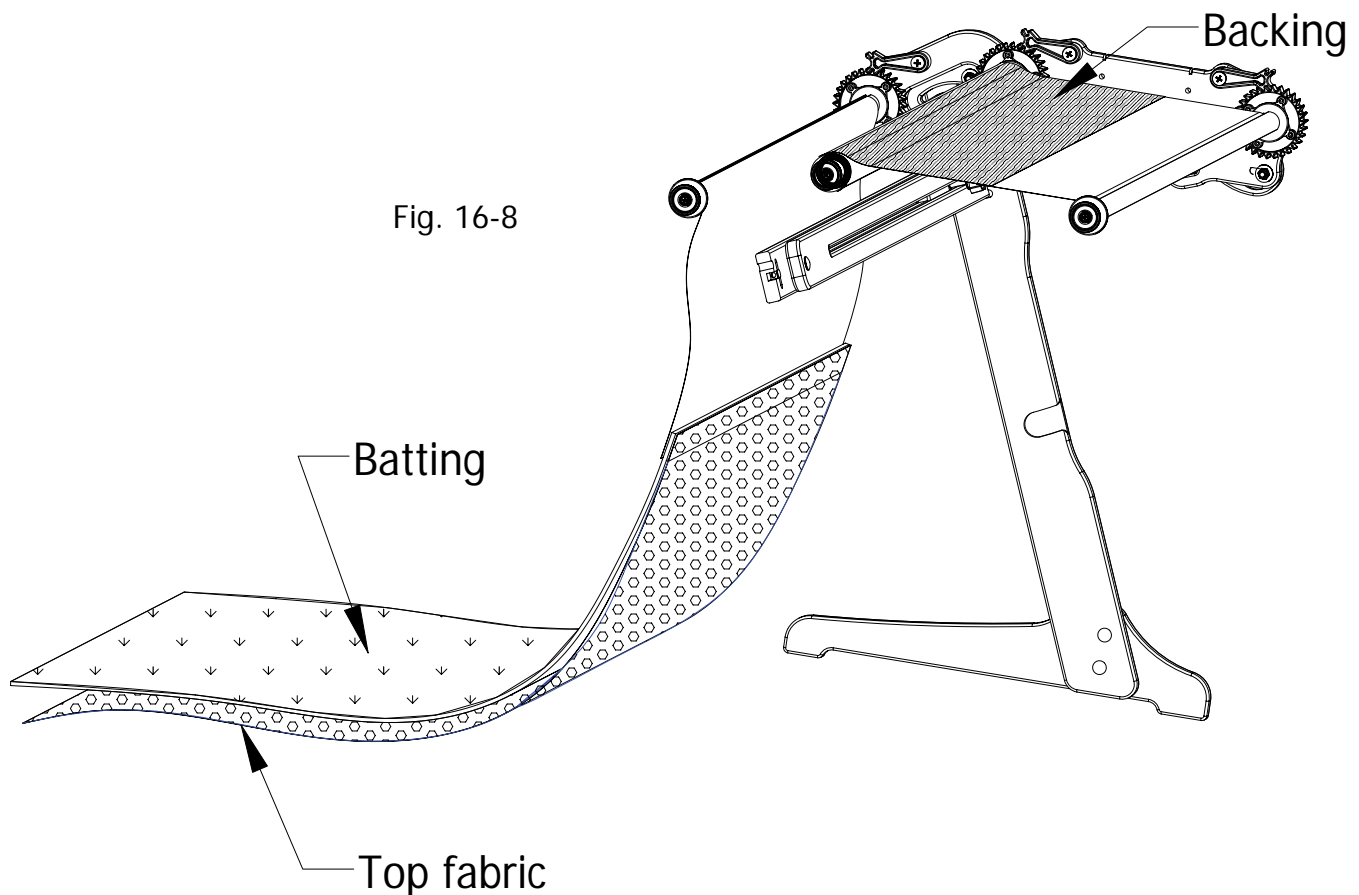

Roll the top/batting onto the rear rail by rolling the rail counter-clockwise, as you did the middle rail. Make sure it rolls smoothly, with no wrinkles as shown in Fig. 16-9.

Remember to smoothly and evenly lay the quilt top to the front rail without stretching from corner to corner during the pinning process.

When you reach the end of the fabric, pull the loose end of the top/batting over the backing and line it up on the front rail as shown in Fig. 16-10.

Completely pin the batting and quilt top moving from the center out to each corner.

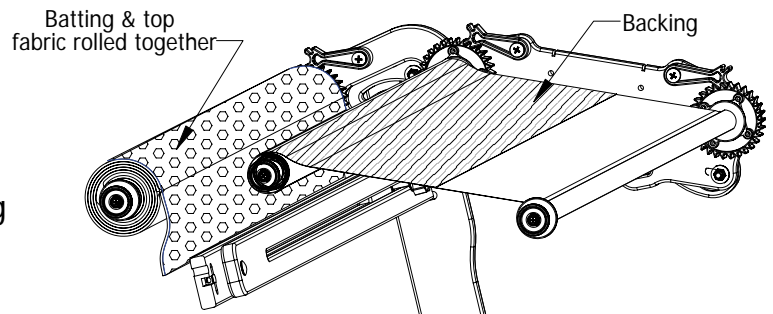

Fig. 16-9

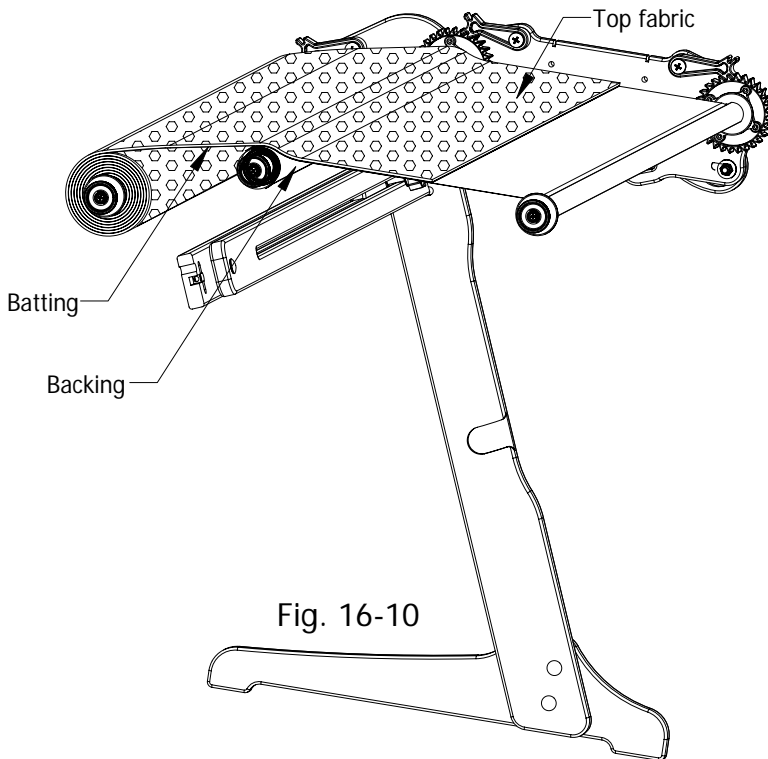

Fig. 16-10

Method #2: Installing fabric directly to rails

This method works well if your quilt top is a single piece and your backing is also one piece.

In this method you bypass using cloth leaders and simply make a $\frac{3}{4}$ " hem or casing at either each of your backing (or draw or sew a straight line about $\frac{1}{2}$ " from each edge).

Next, insert the fabric retaining tube into the hem/casing, but if using the line method, push the fabric into the slot of the rail, following the straight line the entire way.

Push the tubing with fabric securely into the rail the entire length of your frame.

Apply the fabric in the same order as outlined in "Applying quilt fabric to leader cloth" on page 20-23.

1. Backing to middle rail (Fig. 16-5 pg. 21)
2. Backing to front rail (Fig. 16-7 pg. 21)
3. Top and batting to back rail (Fig. 16-8 pg. 22)
4. Top and batting to front rail (Fig. 16-10 pg. 23)

NOTE: The batting should not be inserted into the rail slots. Instead it should lie right up next to the slot. It may be pinned to secure it in place, if desired.

Troubleshooting

Problem: Puckering is occurring throughout the quilt top as soon as it's removed from the frame.

Solution: Uneven tension was applied to the quilt layers (ex: if the top has puckers, the bottom was rolled faster or tighter than the top). This is a common mistake. It is **VERY IMPORTANT** that you use as little front-to-back tension on your fabric as possible! It is much easier to keep the tension equal on the backing, and top if you keep the tension minimal from beginning to end.

Problem: Fabric sags on one side or in middle.

Solution: The fabric may not be cut straight or the grain of the cloth may not be square. The fabric may also be slightly wrinkled in some areas. Take off the fabric and square it up, or partially unroll, and pull (gently) while re-rolling the fabric to square it up

Problem: Sides of quilt have a concave edge.

Solution: The fabric was stretched along the rail. Take the fabric off and let it relax until it is not misshapen and then re-install, without stretching it along the edge.

Problem: Batting tears or separates during the tightening of the ratchet wheels. The Batting has been stretched, or stressed.

Solution: One thing can prevent this problem is to make the batting longer than the Quilt that you are making. There should never be any tension applied to the batting. Another alternative is to use a few extra inches of Batting and let it sag down between the two rear rails. This will stop the Batting from pulling. You may unroll the rear rail and fix the Batting at any time during the quilting process.

Problem: Rails are bowing in.

Solution: The causes may be: 1. Seam down the center of the Fabrics may be sewn too tightly and is not giving with the rest of the Fabric. If the Seam is the problem the Quilt may be attached sideways, 2. Fabric is not cut evenly. 3. Too much tension has been applied. 4. Fabric has been stretched along the Rails instead of naturally laid along the Rails then attached.

Tips for Tying Quilts

Before installing the Quilt onto the Frame, mark both the Quilt Top and Backing in similar increments along the two side edges. (The sides that are not tacked onto the Rails.) While rolling the Quilt during the tying process watch the marks. This will help you to keep an equal tension on the Top and Backing Fabrics so you won't over tighten one or the other of your Fabrics. Important! When rolling into a new area of tying, allow your last row of ties to remain in the new area of tying. Also, tie your knots tight. DO NOT over roll your last row of ties over the turn in the rail.