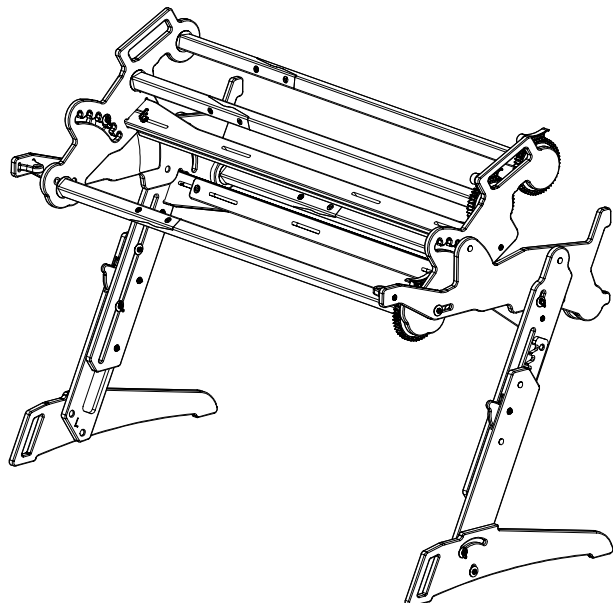



TABLE OF CONTENTS

CARE, FINISHING AND STORAGE.....2
 WARRANTY.....2
 PARTS LIST.....3-4
 ASSEMBLY STEPS
 STEP 1: HARDWARE TO LEFT AND RIGHT POLE MOUNT ENDS.....5
 STEP 2: HARDWARE AND LAMP HOLDERS TO LEFT AND RIGHT PIVOT SECTIONS.....6
 STEP 3: HARDWARE AND HEIGHT SET PIECE TO UPPER DIAGONAL STANDS.....7
 STEP 4: HARDWARE AND HEIGHT ADJUSTING LEVER TO LOWER DIAGONAL STANDS.....8
 STEP 5: UPPER AND LOWER DIAGONAL STAND SUB-ASSEMBLY.....9
 STEP 6: POLE MOUNT AND PIVOT SECTION SUB-ASSEMBLY.....10
 STEP 7: LEFT AND RIGHT FOOT & DIAGONAL STAND SUB-ASSEMBLY.....11
 STEP 8: LEFT AND RIGHT COMPLETE SIDE ASSEMBLY.....11
 STEP 9: BRACE ASSEMBLY.....13
 STEP 10: BRACE TO STAND ASSEMBLY.....15
 STEP 11: POLE ASSEMBLY.....16
 STEP 12: POLE TO END ASSEMBLY.....18
 STEP 13: FINAL FRAME ADJUSTMENTS.....19
 FOLDING AND STORING YOUR Z44™ PROFESSIONAL.....19
 TILTING YOUR Z44™ PROFESSIONAL.....20
 ADJUSTING THE HEIGHT OF THE Z44™ PROFESSIONAL.....21
 USE OF ACCESSORIES.....22
 QUILTING INSTRUCTIONS AND TIPS.....23
 MAKING AND USING CLOTH LEADERS.....23
 FABRIC INSTALLATION.....25
 TROUBLE SHOOTING.....28
 SPECIAL TIPS FOR TYING QUILTING.....29



Caring for Your Z44™ Professional

Your Z44™ Professional Quilting Frame is a sturdy frame that can be used finished or unfinished. For extra protection, or to give it a finished look, you may seal, stain and/or finish the frame using a number of different applications. This is best done BEFORE YOU ASSEMBLE your frame.

To seal the wood, we recommend an application of tung oil that will help preserve the wood and will help to prevent warping. To add a certain color to your frame, you may use a Danish Oil finish. We recommend the Deft™ or Watco™ brands. Some prefer to use a urethane coat to add a more glossy finish.

Test stain on an inconspicuous place. Many different finishes and/or stains may be suitable for sealing and beautifying your frame. You may want to consult your local paint retailer for finishes that are easy to apply and dry hard—not oily.

Use and Storage Tips

--Store frame in a dry place. If not assembled, store with poles and braces in vertical position. (This will prevent floor moisture from seeping into the poles).

--Do not carry the assembled frame by the quilting poles. Hold the braces instead.

--Do not drop the frame or let it twist out of square.

Lifetime Limited Warranty

GraceWood, Inc. will replace or repair, at our choosing, any part of the Grace Z44™ Professional Quilting Frame, which may be shown to be defective. This Lifetime Warranty does not cover parts damaged through misuse, improper storage, improper assembly, loss, natural events and willful or accidental destruction. Defective parts may be returned only with a valid RMA# which may be obtained by calling GraceWood, Inc. at **1-800-264-0644**.

Warranty card must be filled out, stamped and mailed to the address on the card within 30 days of purchase.

Contact Information

*For Technical Support or any other correspondence concerning your Z44™ Professional Quilting Frame, call **1-800-264-0644** ~*

*OR ~ **E-mail: robin@graceframe.com** ~ OR ~ **Fax: (801) 485-4388** ~*

OR ~ Write to:

The Grace Company

P.O. Box 27823

Salt Lake City, UT 84127

For details on accessories and other information, see us online at www.graceframe.com

For shipping of materials to The Grace Company address package (postage prepaid) to: The Grace Company, 2275 South 3200 West, SLC, UT 84119. Materials may be returned only with a valid RMA# or Returned Merchandise Authorization Number which may be obtained by calling GraceWood, Inc. at **1-800-264-0664**.

If you call after business hours (M-F 8:00 a.m. – 5 p.m., MST) be assured that your call will be returned the next business day if you leave a message. Please report any errors in these instructions or make constructive comments to the following: jaren@graceframe.com

Grace Quilting Frames and Hoops: Innovation and Evolution

Grace Quilting Systems have been developed over the past two decades with several original design innovations. Additionally, because feedback from many of the thousands of quilters who have purchased and use the GraceFrame™, we have been able to make a frame that will truly enhance the entire process of hand quilting from beginning to end. If you have any suggestions that will help us to improve our product or service, let us know, using one of the above contact methods.

Z44 Professional Parts List

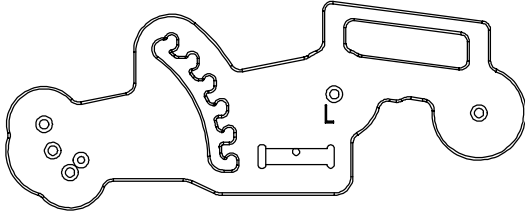

1-Left Pole Mount End

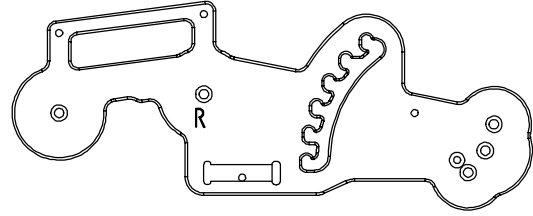

1-Right Pole Mount End

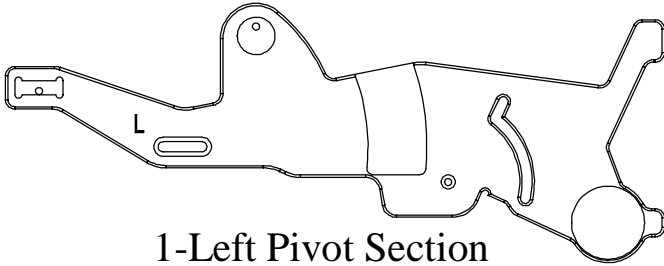

1-Left Pivot Section

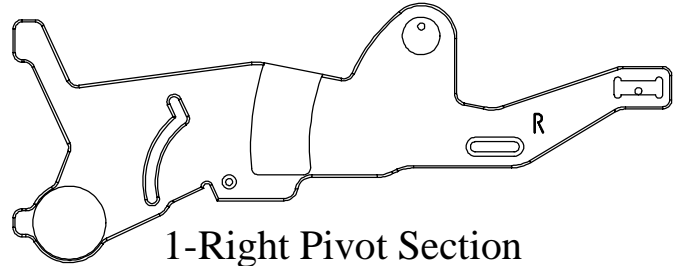

1-Right Pivot Section

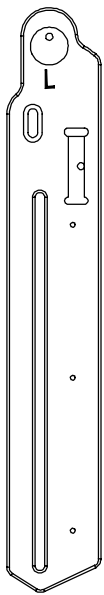

1-Left Upper Diagonal Stand

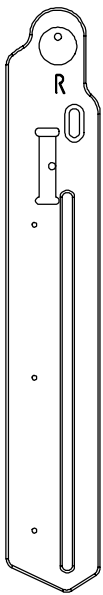

1-Right Upper Diagonal Stand

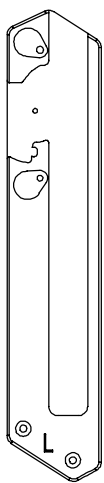

1-Left lower Diagonal Stand

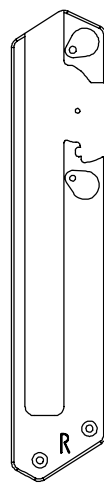

1-Right lower Diagonal Stand

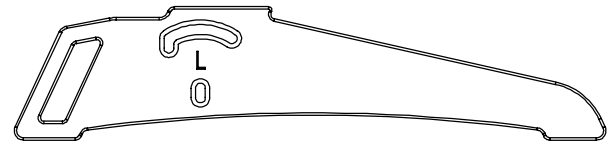

1-Left Foot

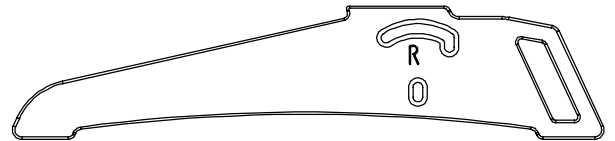

1-Right Foot

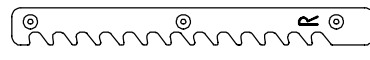

1-Right Height Set



1-Right Height Adjusting Lever

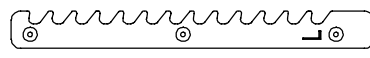

1-Left Height Set



1-Left Height Adjusting Lever



2-Lamp Holder

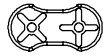

1-Wing Grip Tool



4-Braces

Pole Parts

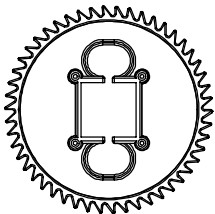

3-50 Tooth Ratchet Wheel



3-Ratchet Stop



4-Pole Cap



8-Guide Dowel

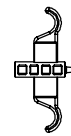

4-Quick Release Pole Hook

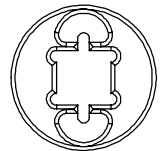

1-4th Pole Hand Wheel

Hardware Parts List

Drawings display hardware in actual size

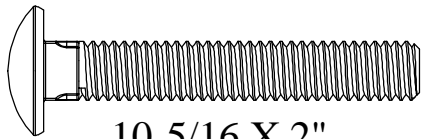

10-5/16 X 2"
Carriage Bolt

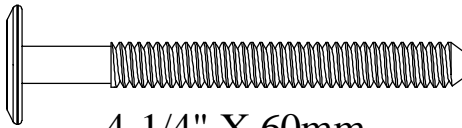

4-1/4" X 60mm
Connector Bolt

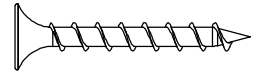

8-1 1/4" Grabber
Screw

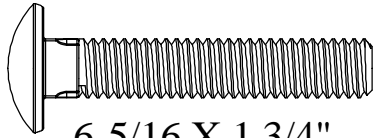

6-5/16 X 1 3/4"
Carriage Bolt

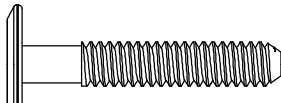

18-1/4" X 35mm
Connector Bolt



8-5/16" Wing
Nut

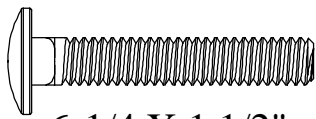

6-1/4 X 1 1/2"
Carriage Bolt

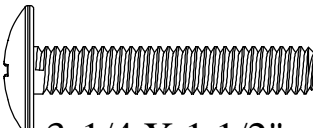

3-1/4 X 1 1/2"
Truss Bolt



6-Spring

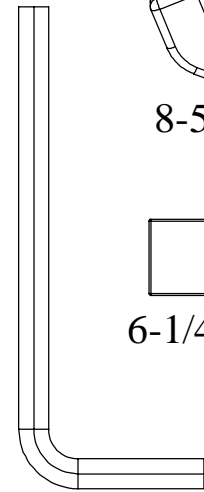

1-4mm Allen
Wrench

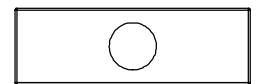

6-1/4" Rectangle
Nut

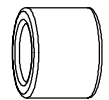

24-Plastic
Rollers

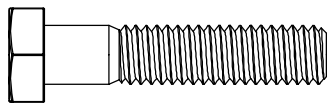

4-5/16 X 1 1/2"
Hex Bolt

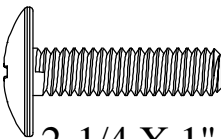

2-1/4 X 1"
Truss Bolt

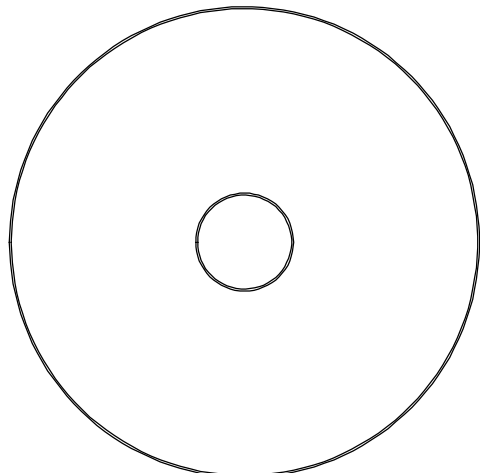

8-Nylon Washer

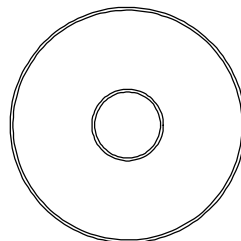

16-1 1/4" Fender
Washer

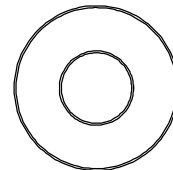

4-5/16" Flat
Washer

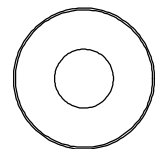

24-1/4" Flat
Washer

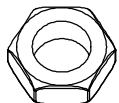

16-5/16"
Jamb Nut

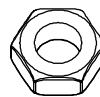

6-1/4"
Jamb Nut



8-5/16"
Nylock Nut



2-1/4"
Nylock Nut

Pole List

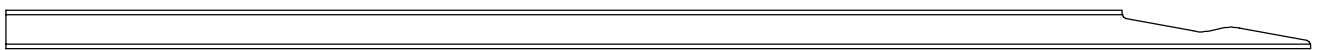

4-55 1/2" Pole



4-48 1/2" Pole

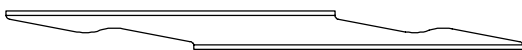

4-22" Pole

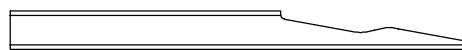

4-19 1/2" Pole

Assembly of the Z44™ Professional Quilting Frame

BEFORE YOU BEGIN

Using the preceding parts list as a reference, take the parts out of the box and make sure your package is complete. (If there is something missing or damaged, **do not call the store or dealer from whom you purchased the product**. Please contact The Grace Company directly at **1-800-264-0644**).

TOOLS NEEDED

To assemble your frame, you will need the following common tools:

1. One 1/2" wrench
2. Phillips Head Screw Driver
2. One 7/16" wrench (A combination or socket wrench is preferable)
3. Flat Head Screw Driver
4. Wing Grip Tool (to easily tighten and loosen wing nuts--***provided***)
5. Allen Wrench (***provided***)

- **Note:** To help you distinguish between wood parts, all Left Side parts are marked with an "L" grooved into the wood on the inside of the part. Right side parts are marked with an "R" on the inside. The first four steps will involve installing hardware into parts and performing other sub-assemblies in preparation for further steps.
- This is a new product! We welcome your feedback on this product or these instructions. If you encounter a problem during assembly or use of the Grace Z44™ Professional, and you can't seem to overcome it, call us before frustration sets in! ☺ **1-800-264-0644**.
- **NOTE!** Read each step all the way through before actually assembling parts in that step.

STEP 1: HARDWARE TO LEFT AND RIGHT POLE MOUNTS ENDS

PARTS NEEDED: 1 – LEFT POLE MOUNT END
 1 – RIGHT POLE MOUNT END
 2 – 5/16" X 1 3/4" CARRIAGE BOLT
 2 – 1/4" FLATWASHER
 2 – 5/16" JAMB NUT

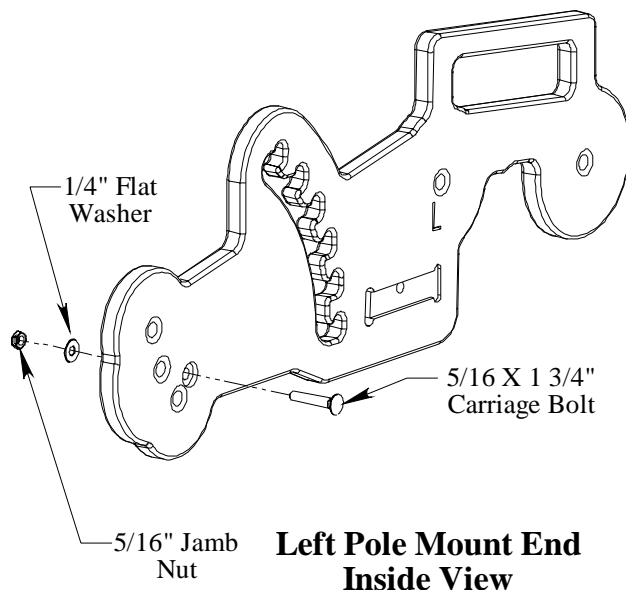

- First, distinguish all the shorter 5/16" x 1 3/4" carriage bolts from the others, using the parts list as a reference (all hardware in the parts list is shown in actual size).
- Put a 5/16" x 1 3/4" carriage bolt through the inside hole as shown in the illustration (see left). Make sure the head of the bolt is on the inside of the part (marked with an "L"), and comes out the outer side of the part.
- Place a 1/4" flat washer (smallest) and a 5/16" jamb nut onto the end of the carriage bolt and completely tighten the jamb nut onto the bolt **until the head**

of the bolt is pulled into the counter-sunk hole.

- **NOTE!** Failing to tighten jamb nuts in these initial steps will lead to assembly problems in further steps. Be sure to **completely tighten** each jamb nut as instructed!
- Repeat these instructions for the Right Pole Mount End (see right).

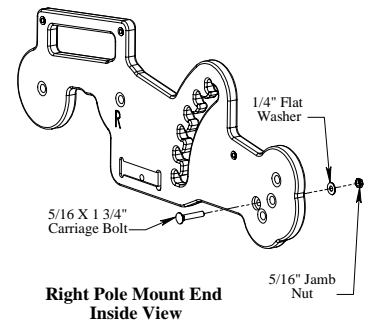

STEP 2: HARDWARE AND LAMP HOLDERS TO LEFT AND RIGHT

PIVOT SECTIONS

PARTS NEEDED:	1 – LEFT PIVOT SECTION	2 – 1/4" X 35MM CONNECTOR BOLT
	1 – RIGHT PIVOT SECTION	4 – 5/16" X 2" CARRIAGE BOLT
	2 – LAMPHOLDER	4 – 5/16" JAMB NUT
	2 – 1/4" RECTANGLE NUT	4 – 1/4" FLAT WASHER

- Begin by putting the four 5/16" x 2" carriage bolts into the two holes on each piece as shown below.
- The upper hole on each part gets the carriage bolt **with the head of the bolt on the outer side** of the Pivot Section.
- The lower hole gets the carriage bolt **with the head of the bolt on the inner side** of the Pivot Section (marked with an "L").
- With these bolts in place, put one 1/4" flat washer and 5/16" jamb nut onto each bolt. Tighten the jamb nuts **completely**.
- Attach the Lamp Holder to the Pivot Section by placing a 1/4" x 35mm connector bolt through the hole at the front of the Pivot Section, with the head of the bolt on the outer side. Place a 1/4" rectangle nut in the cross slot of the Lamp Holder and thread the bolt through the nut (**see close-up right**).

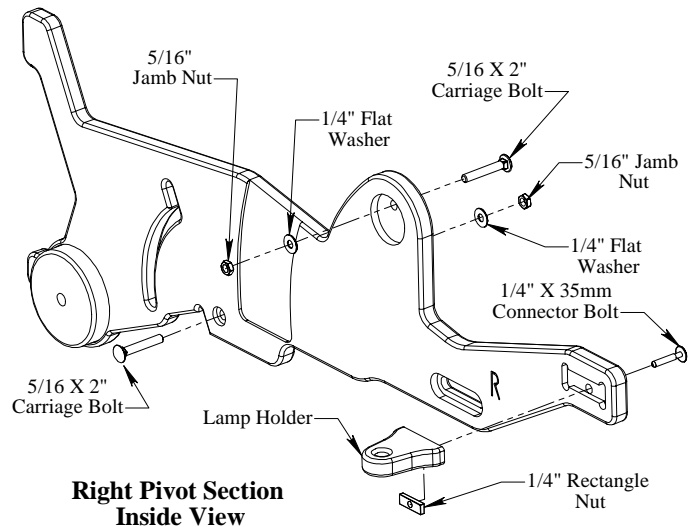
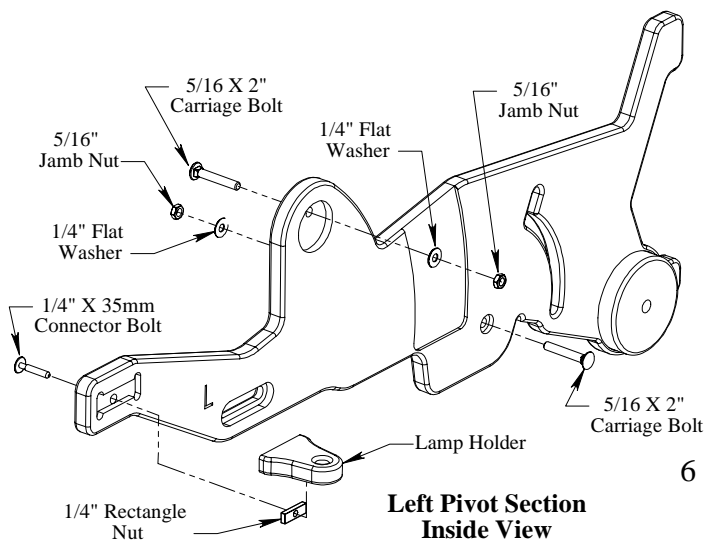
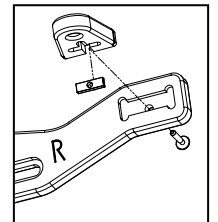

STEP 3: HARDWARE AND HEIGHT SET TO UPPER DIAGONAL STANDS

PARTS NEEDED:	1 – LEFT UPPER DIAGONAL STAND	1 – RIGHT UPPER DIAGONAL STAND
	1 – LEFT HEIGHT SET	1 – RIGHT HEIGHT SET
	2 – 5/16" X 2" CARRIAGE BOLT	6 – 1/4" X 1 1/2" CARRIAGE BOLT
	6 – 1/4" JAMB NUT	2 – 5/16" JAMB NUT
	8 – 1/4" FLATWASHERS	

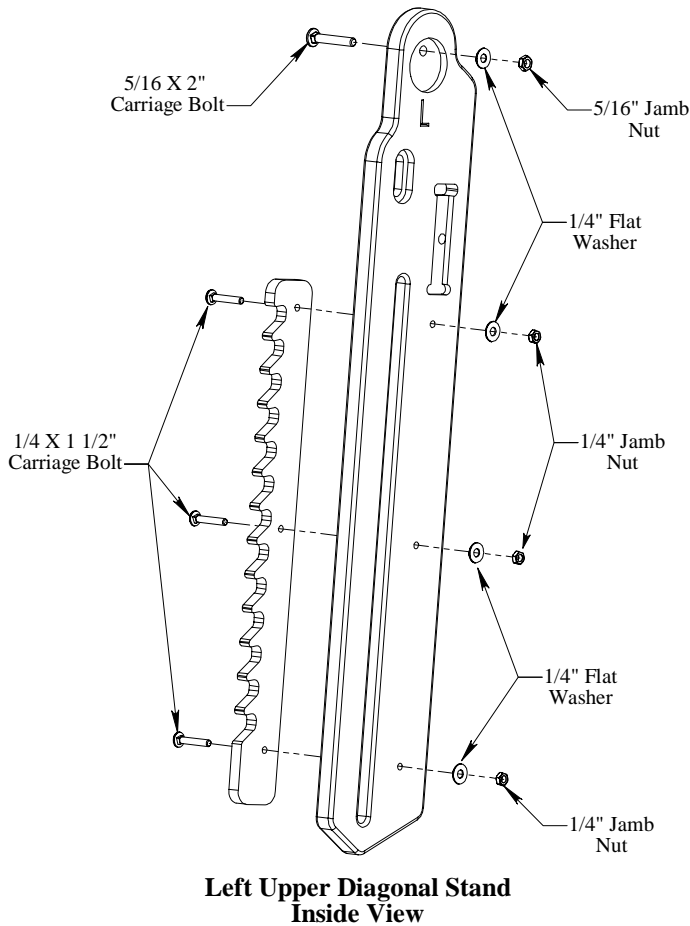

- First, put a 5/16" x 2" carriage bolt through the uppermost hole of the Left Upper Diagonal Stand. The head of the bolt should be on the outer side of this part.
- Place a 1/4" flat washer and a 5/16" jamb nut onto the end of the bolt and **completely tighten** the jamb nut.
- Position the Left Height Set to the outer side of the Left Upper Diagonal Stand as pictured (see left). The "L"s should face opposite directions.

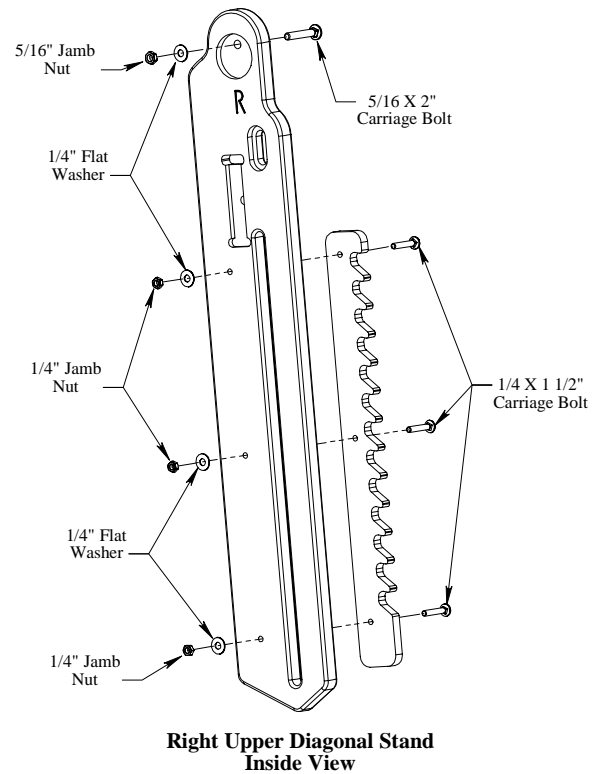

- Connect the two pieces using three 1/4" x 1 1/2" carriage bolts, starting them through the Height Set and into the Left Upper Diagonal Stand as pictured above. **NOTE:** The holes are just big enough to allow the bolts through with a minimum of extra "wiggle-room." You may need a mallet or hammer to nudge the bolts through.
- Fasten the two pieces by placing a 1/4" flat washer and 1/4" jamb nut (smaller) onto the end of each 1/4" carriage bolt.
- Repeat these instructions for the Right Upper Diagonal Stand and Height Set.

STEP 4: HARDWARE AND HEIGHT ADJUSTING LEVER TO LOWER DIAGONAL STANDS

PARTS NEEDED:	1 – LEFT LOWER DIAGONAL STAND	1 – RIGHT LOWER DIAGONAL STAND
	1 – LEFT HEIGHT ADJUSTING SET	1 – RIGHT HEIGHT ADJUSTING SET
	4 – 5/16" X 2" CARRIAGE BOLT	10 – 1/4" FLATWASHER
	4 – 5/16" X 1 3/4" CARRIAGE BOLT	2 – 1/4" NYLOCK NUT
	2 – 1/4" X 1" TRUSS BOLT	

- First, thread 5/16" x 1 3/4" carriage bolts through the two lower holes of the Lower Diagonal Stand, with the heads of the bolt on the inner side of the part (marked "L"), as pictured (see left).

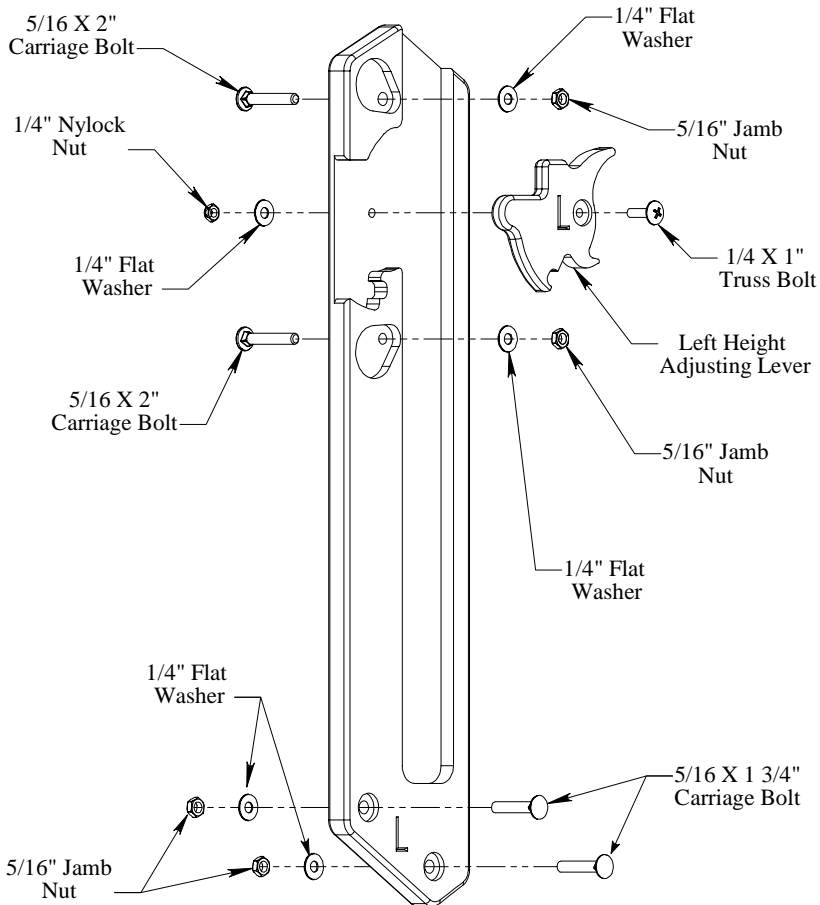

**Left Lower Diagonal Stand
Inside View**

- Finally, attach the Height Adjusting Lever to the Lower Diagonal Stand by putting a 1/4" x 1" truss bolt through the Height Adjusting Lever (head on the "L" side) and then through the inside of the Lower Diagonal Stand.
- Fasten these two parts by placing a 1/4" flat washer and then a 1/4" nylon lock nut onto the end of the bolt (nylon side out) and PARTIALLY tighten onto the bolt (just enough to still allow the washer inside to spin).
- **NOTE!** The nylon lock nuts look just like jamb nuts, except for the thin nylon ring inside. This keeps the bolt from eventually working itself off of a bolt. When tightening nylock nuts at movable points like this one, *it is important not to over-tighten!* Tighten this nylock just enough to hold the washer against the wood, but loose enough to allow the washer to turn with your finger.

- Place a 1/4" flat washer and a 5/16" jamb nut onto the end of each bolt, and tighten the jamb nuts completely.
- Next, place the longer 5/16" x 2" carriage bolts into the other two holes of the Lower Diagonal Stand as pictured (left), with the head of the bolt on the outer side.
- Place a 1/4" flat washer and a 5/16" jamb nut onto these two bolts and completely tighten each jamb nut.

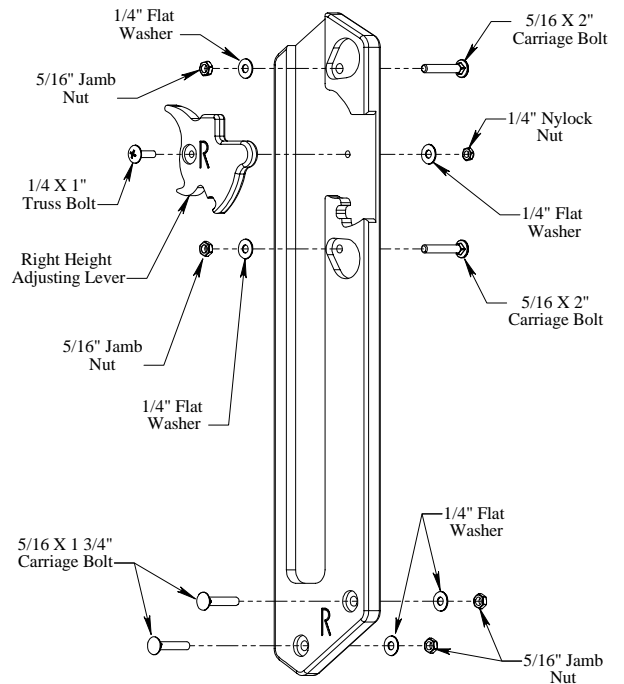

**Right Lower Diagonal Stand
Inside View**

- Repeat these instructions for the Right Lower Diagonal Stand.

STEP 5: UPPER AND LOWER DIAGONAL STAND SUB-ASSEMBLY

PARTS NEEDED:	1 – LEFT UPPER DIAGONAL STAND	1 – RIGHT UPPER DIAGONAL STAND
	1 – LEFT LOWER DIAGONAL STAND	1 – RIGHT LOWER DIAGONAL STAND
	8 – PLASTIC ROLLER	4 – 1 1/4" FENDER WASHER
	2 – 5/16" NYLOCK NUT	2 – 5/16" WING NUT
	2 – SPRING	

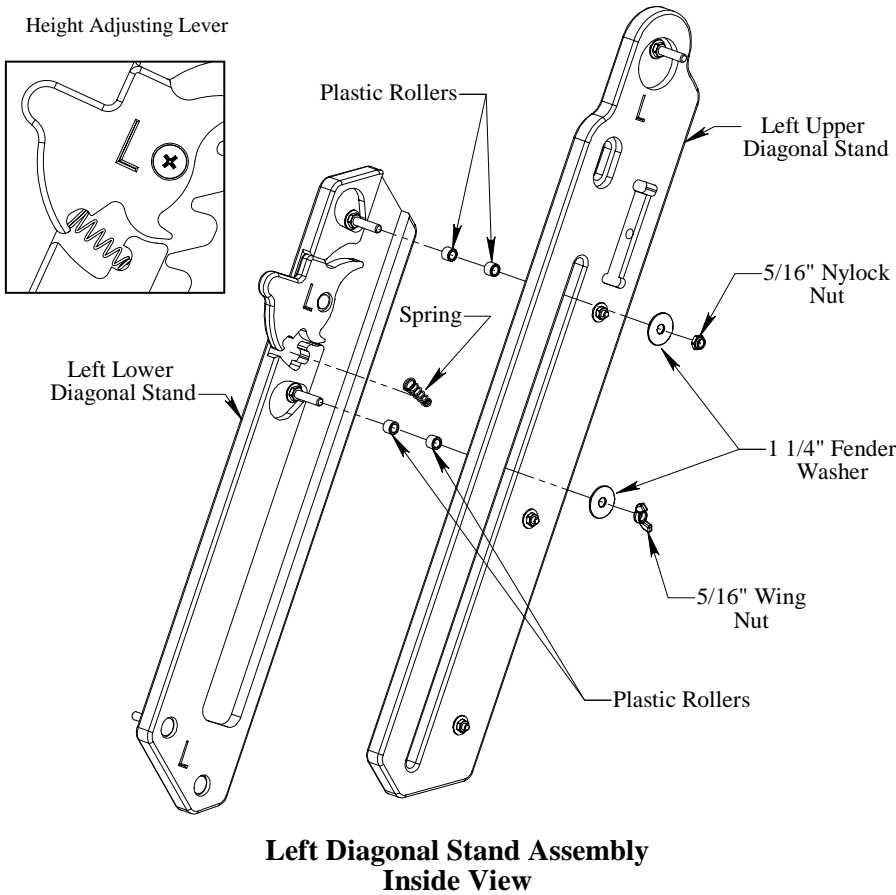

- With the Height Adjusting Lever fastened, place a spring in the open area between the Lever and the Diagonal Stand as pictured (see close-up left).
- Now assemble the Upper and Lower Diagonal Stand parts by lining up the parts as shown. Begin with the left side parts (be sure the "L" side of both parts are facing the same direction).

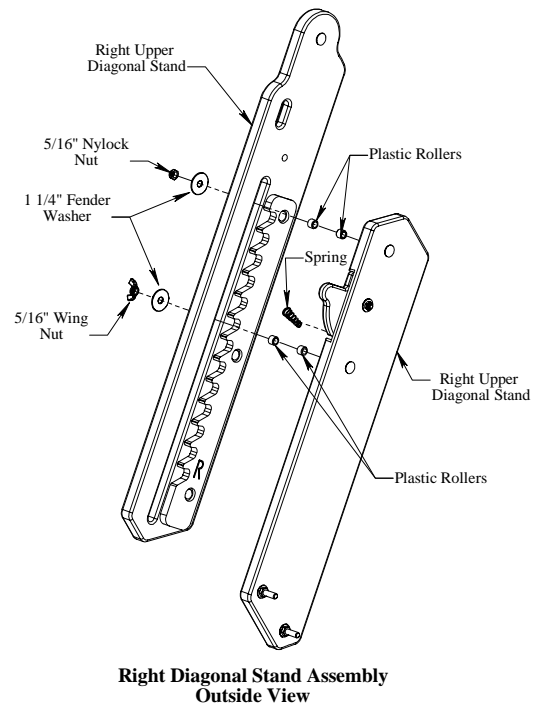

- Place two plastic rollers on each of the two bolts coming through the Lower Diagonal Stand, as pictured.
- Put the two bolts through the long slot of the Upper Diagonal Stand.
- Fasten these parts together by placing one 1 1/4" fender washer on each bolt. Thread a 5/16" wing nut onto the lower bolt, and a 5/16" nylock nut on the upper bolt.
- NOTE! Tighten the nylock nut, leaving it just loose enough to allow the fender washer to freely spin.
- Repeat these instructions for the right side sub-assembly (see right).

STEP 6: POLE MOUNT AND PIVOT SECTION SUB-ASSEMBLY

PARTS NEEDED:	1 – LEFT POLE MOUNT END	1 – RIGHT POLE MOUNT END
	1 – LEFT PIVOT SECTION	1 – RIGHT PIVOT SECTION
	6 – PLASTIC ROLLER	4 – 1 1/4" FENDER WASHER
	2 – 5/16" WING NUT	2 – 5/16" NYLOCK NUT

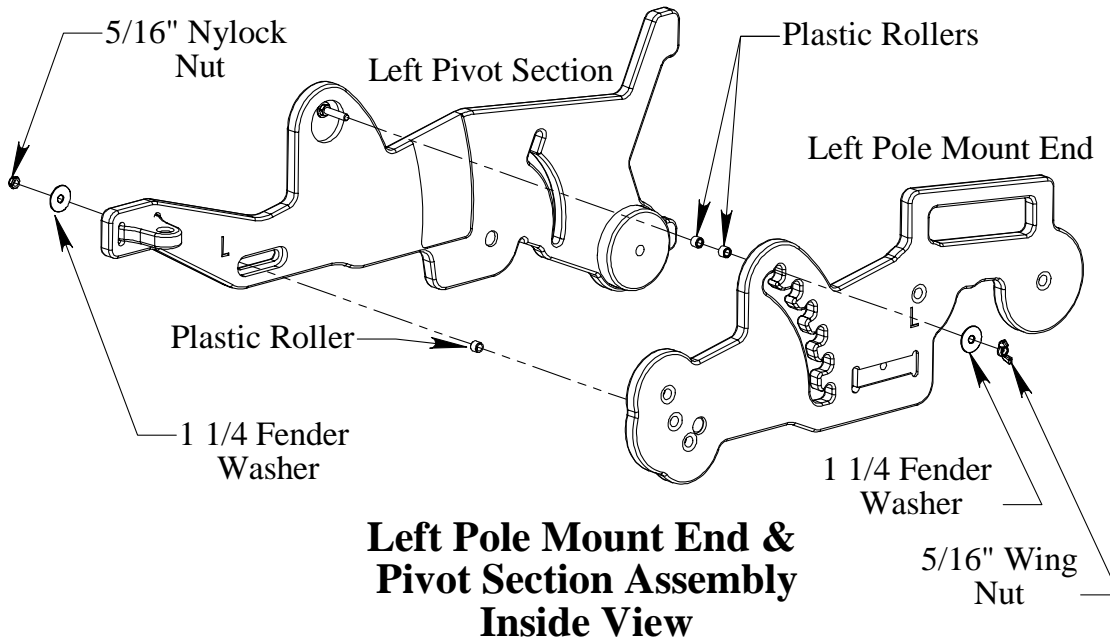

- Now assemble the Left Pivot Section (outside) to the Left Pole Mount (inside) by lining up the parts as shown (be sure the “L” side of both parts are facing the same direction).
- Place two plastic rollers onto the upper bolt coming out of the Pivot Section. Then place one plastic roller onto the bolt coming out of the Pole Mount End.
- The carriage bolt in the Pivot Section goes into the ratchet slot of the Pole Mounting End as pictured.
- The Pole Mounting End’s carriage bolt fits into the horizontal slot (next to the “L”) in the Pivot Section.
- With these pieces together, place an 1 1/4” fender washer onto both carriage bolts.
- Thread a wing nut on the top (inside) carriage bolt (in the ratchet slot).
- Thread a nylon lock nut on bottom carriage (outside) bolt. Tighten the nylock nut, leaving it just loose enough to allow the fender washer to spin.
- Repeat these instructions for the right side.

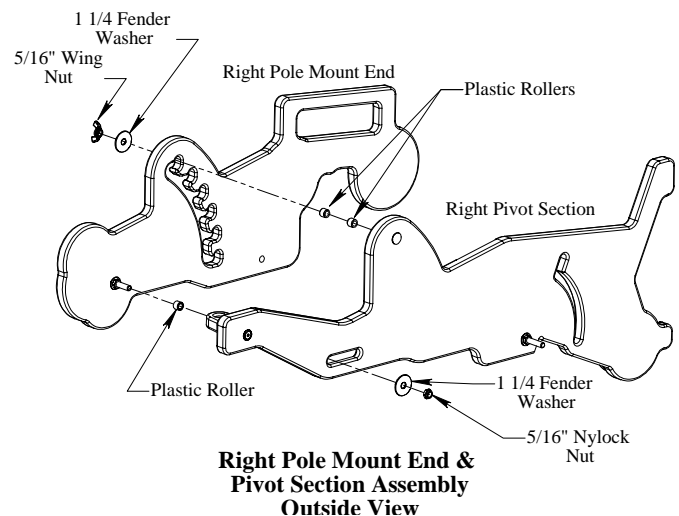

STEP 7: LEFT AND RIGHT FOOT & DIAGONAL STAND SUB-ASSEMBLY

PARTS NEEDED:	1 – LEFT DIAGONAL STAND	1 – RIGHT DIAGONAL STAND
	1 – LEFT FOOT	1 – RIGHT FOOT
	4 – PLASTIC ROLLER	4 – 1 1/4" FENDER WASHER
	2 – 5/16" WING NUT	2 – 5/16" NYLOCK NUT

- Connect the Left Foot to the Diagonal Stand by lining up the parts as shown with the foot to the outside of the stand.
- Be sure the “L” is facing the same direction on both parts.
- Place one plastic roller onto each bolt coming out of the Lower Diagonal Stand.
- Position the parts so the top bolt goes through the curved slot on the upper part of the foot, with the bottom bolt going through the vertical slot.

- With these bolts now coming through the foot, place an 1 1/4" fender washer onto each bolt.

- Thread a wing nut on the top bolt, and a nylock nut onto the bottom bolt.

- NOTE! Tighten the nylock nut, leaving it just loose enough to allow the fender washer to spin.

- Repeat these instructions for the right side assembly.

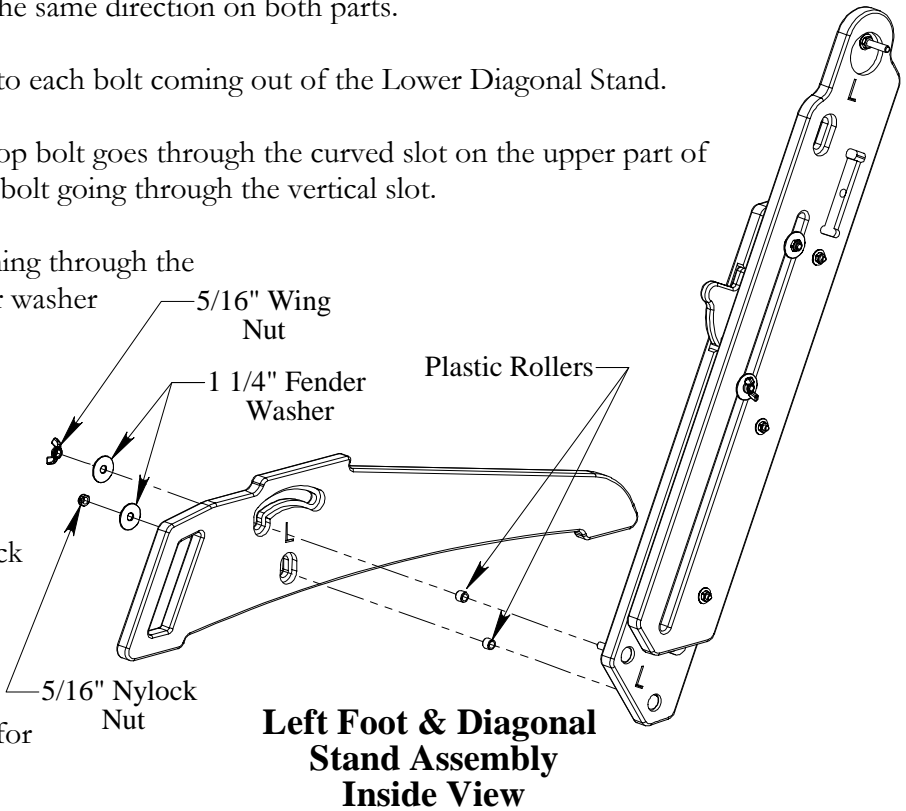

STEP 8: LEFT & RIGHT COMPLETE SIDE ASSEMBLY

PARTS NEEDED:	1 – LEFT FOOT & STAND ASSEMBLY
	1 – RIGHT FOOT & STAND ASSEMBLY
	1 – LEFT MOUNT END/PIVOT ASSEMBLY
	1 – RIGHT MOUNT END/PIVOT ASSEMBLY
	6 – PLASTIC ROLLER
	4 – 1 1/4" FENDER WASHER
	2 – 5/16" NYLOCK NUT
	2 – 5/16" WING NUT

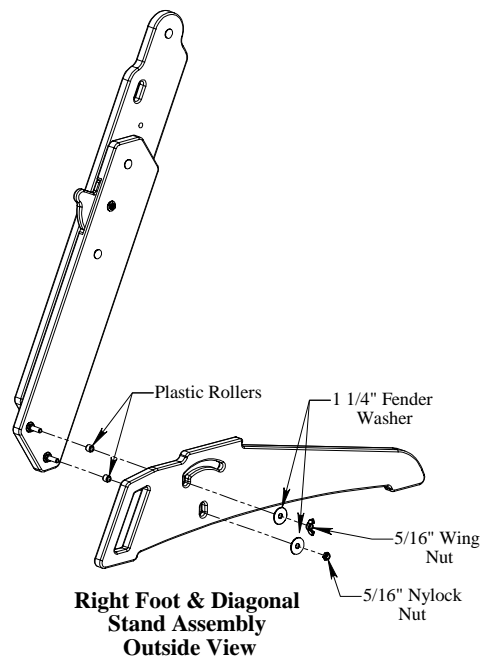

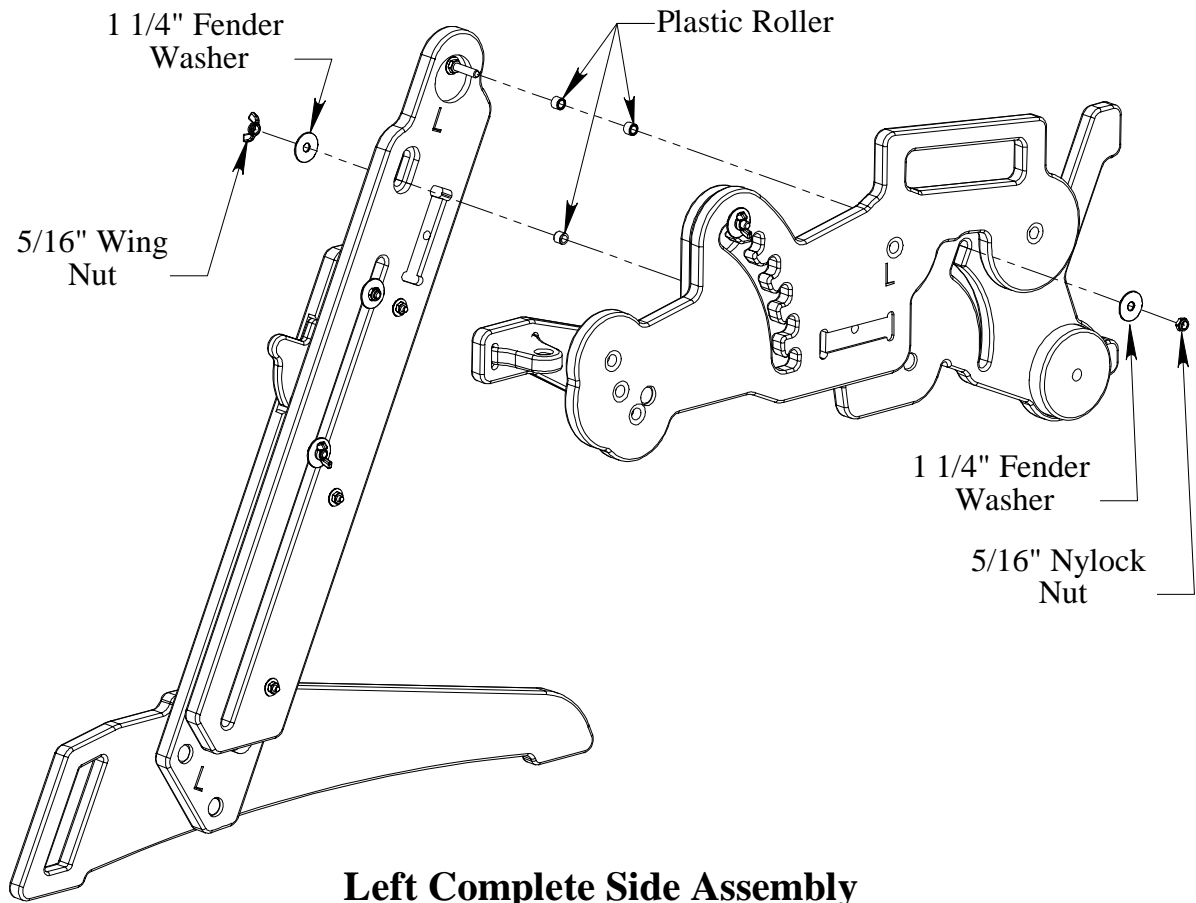

**Left Complete Side Assembly
Inside View**

- Beginning with the left side assembly, position the Pivot Section/Pole Mount End sub-assembly to the assembled Diagonal Stand as pictured, with the “L” facing the same direction on all parts.
- Place two plastic rollers onto the top bolt coming out of the Upper Diagonal Stand.
- Place one plastic roller onto the bolt coming from the Pivot section.
- Place the assembly together so that the top bolt from the Diagonal Stand goes into the long slot of the Pivot Section. The Pivot Section bolt goes into the slot just below the “L” of the Diagonal Stand (see above).
- With these parts together, place a fender washer onto each bolt.
- Thread a wing nut onto the outside (lower) bolt and a nylock nut onto the inside (top) bolt.
- NOTE! Tighten the nylock nut, leaving it just loose enough to allow the fender washer to spin.
- Repeat these instructions for the right side

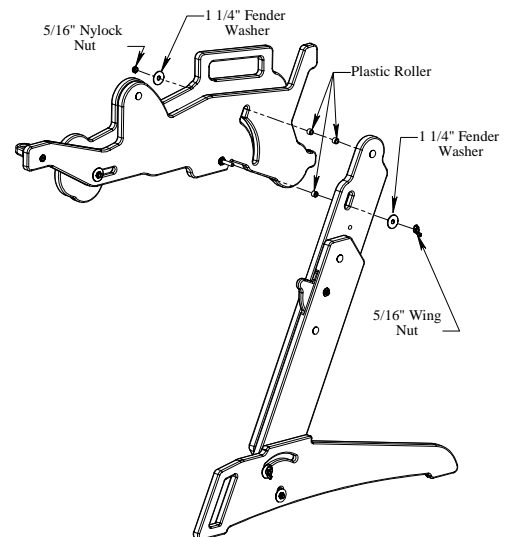

**Right Complete Side Assembly
Outside View**

STEP 9: BRACE ASSEMBLY

PARTS NEEDED: 4 – BRACES
 4 – 5/16" X 1 1/2" HEX BOLT
 4 – 5/16" FLATWASHER

- In this step, you will pair the brace pieces together to form the upper and lower brace sets.
- Take two braces and line them up with each other as pictured. (Now is the time to select the size of frame you want to initially assembly. See the chart on the following page for guidance. Crib size is pictured on this page).
- **IMPORTANT! Be sure the inserted metal T-Nut on the end of each brace is facing away from the other brace (toward the outside)!**
- Place a 5/16" x 1 1/2" hex bolt **with 5/16" (larger) flat washer** through the selected long slot of the one brace and into the hole and T-nut of the other brace.
- Repeat these instructions for the other set of braces.
- LEAVE THE HEX BOLTS LOOSE AT THIS POINT, ALLOWING THE BRACES TO TELESCOPE IN AND OUT.

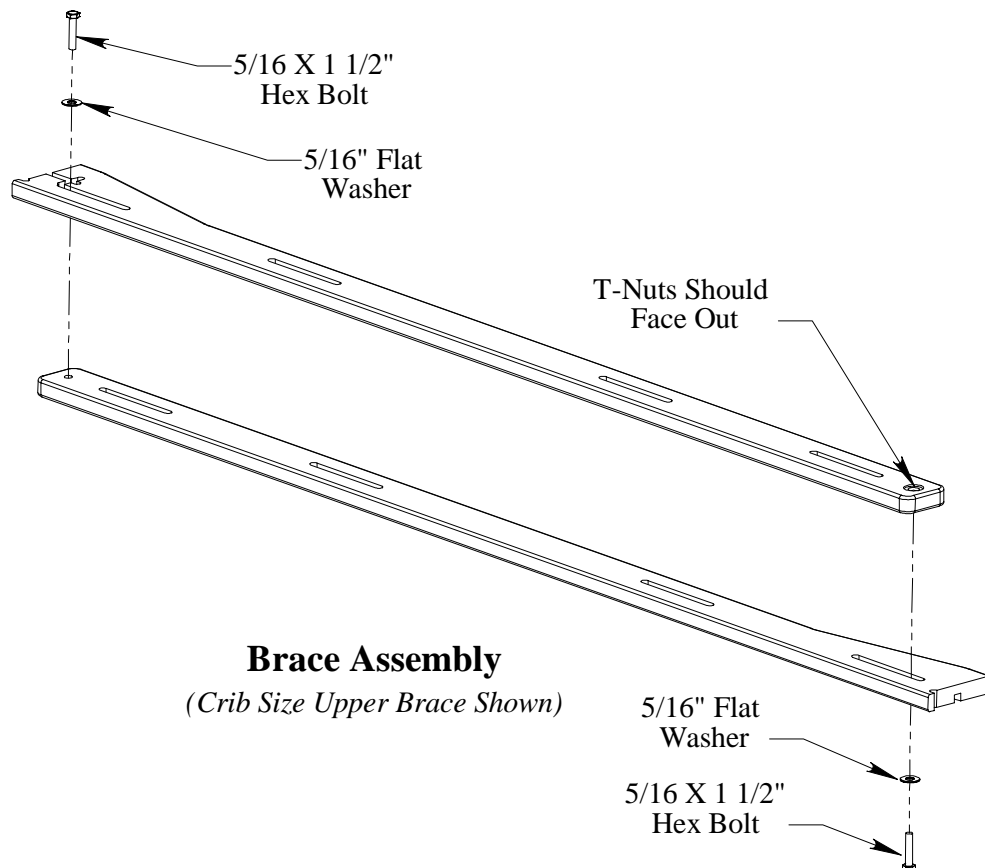

Brace Sizes

Crib Size(59" quilting space)

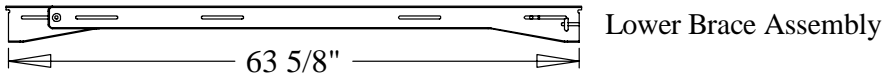

Twin Sizes(73" quilting space)

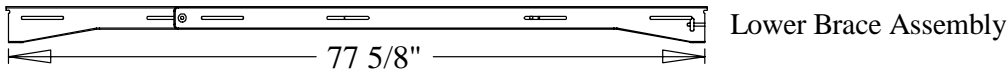

Queen Size(95" quilting space)

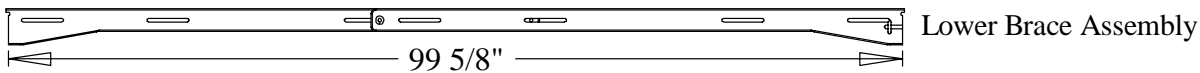
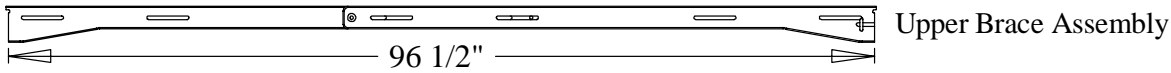

King Size(109" quilting space)



*****Optional Super King Size(123" quilting space)*****

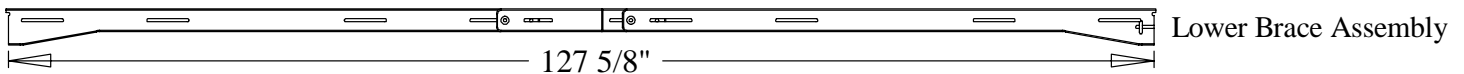

*****Optional Extra Long Super King Size(143" quilting space)*****

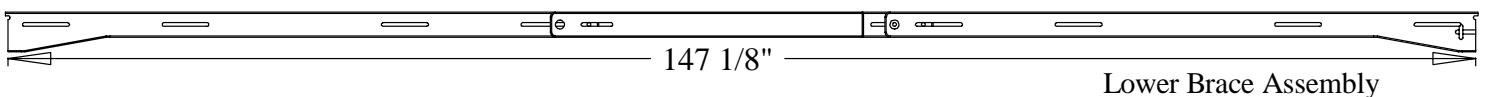
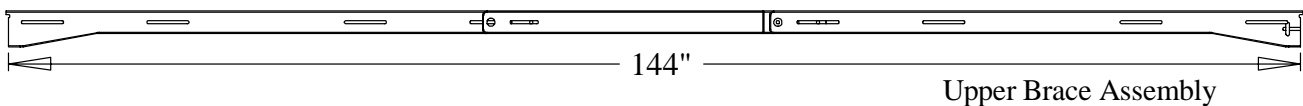

STEP 10: BRACE TO STAND ASSEMBLY

PARTS NEEDED:	1 – LEFT COMPLETE SIDE	1 – RIGHT COMPLETE SIDE
	2 – BRACE ASSEMBLY	4 – 1/4" X 60 MM CONNECTOR BOLT
	4 – 1/4" RECTANGLE NUT	

- Note that the two sets of braces are interchangeable as the upper and lower sets.
- Before you begin, the right and left sides will have to be positioned as pictured below (feet down, pivot section upright, and pole mount positioned in a high tilt setting (*at least four slots high-enough to expose the brace slot hole in the Pole Mount End*)).
- Begin with the lower brace. Align the keyed end of the brace into the slots located on the inside of the Diagonal Stand.
- Place a connector bolt through the hole of the Diagonal Stand (from the outside) and into the keyed end of the brace.
- Place a rectangle nut in the cross slot of the brace so that its threaded hole lines up with the bolt. Thread the bolt through the rectangle nut and completely tighten using the allen wrench. Repeat these instructions for both ends of the brace.
- Now position the Upper Brace assembly into the slots of the raised Pole Mount End, as pictured.
- Repeat the steps above using the 60 mm bolts and rectangle nuts, completely tightening all bolts with the allen wrench. **CONTINUE TO LEAVE THE HEX BOLTS THAT CONNECT THE BRACES TO EACH OTHER LOOSE AT THIS POINT.**

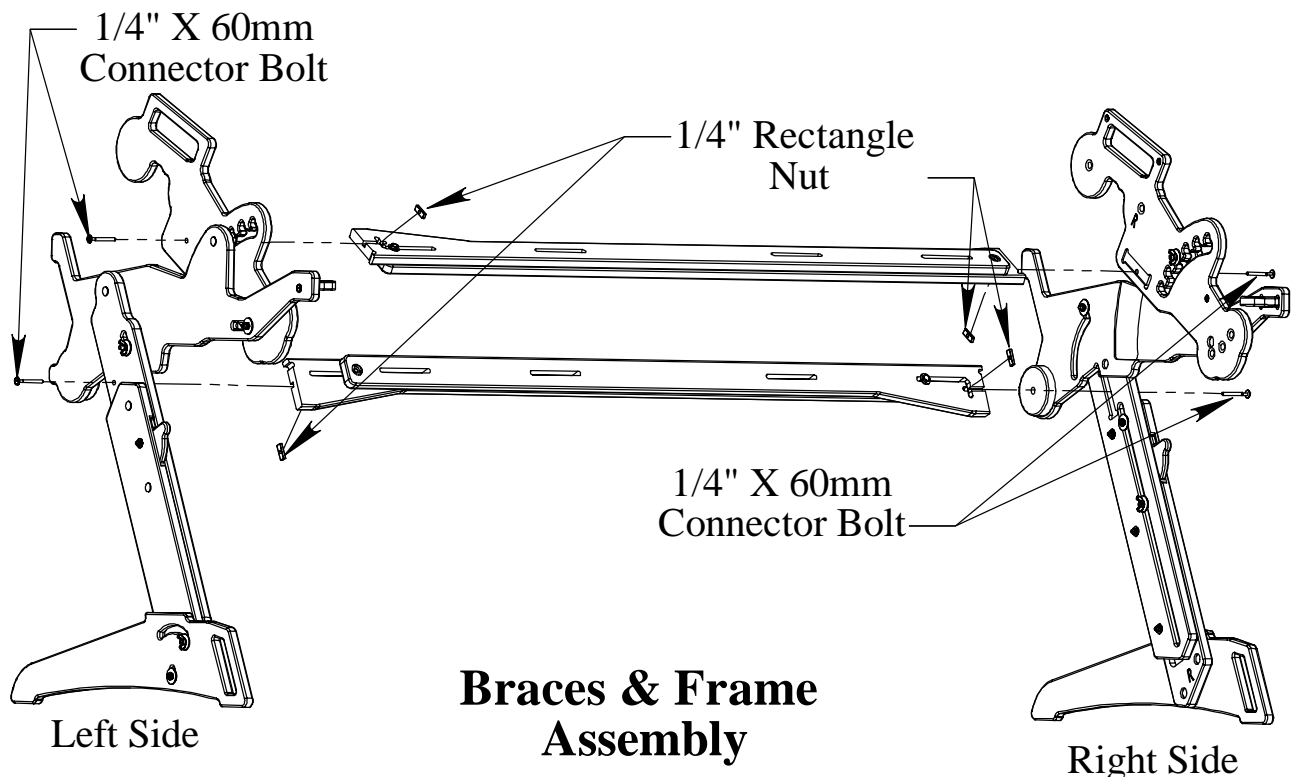

STEP 11: POLE ASSEMBLY

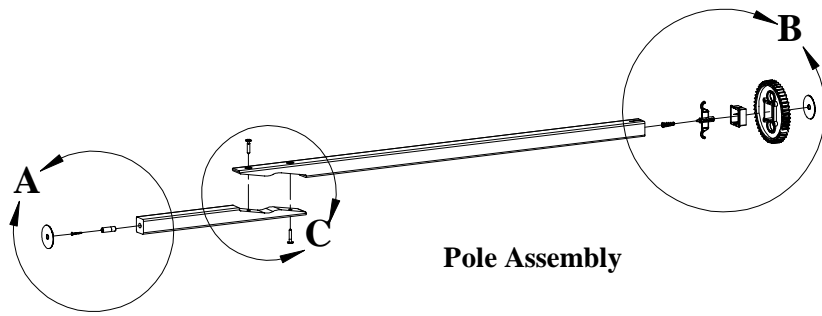

PART A: “F” and “E” Pole Assembly

PARTS NEEDED:	4 – “F” POLE	4 – “E” POLE
	8 – GUIDE DOWEL	8 – 1 1/4” GRABBER SCREW
	8 – NYLON WASHER	

- First, you will assemble the “F” (55 1/2”) and “E” (19 1/2”) poles. Gather these poles together along with the grabber screws and Guide Dowels.

- Insert a Guide Dowel into the ends of each “F”, and “E” poles WITH THE SMALLER HOLE OF THE GUIDE DOWEL INWARD.

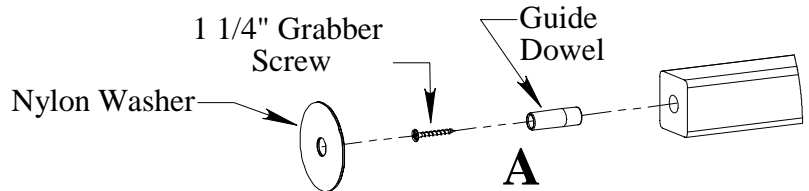

- Insert a grabber screw into a Guide Dowel. Using a Phillips Screwdriver, screw the grabber completely into the rail.
- Place a nylon washer onto the end of each “F” and “E” pole.

PART B: “D” Pole Assembly

PARTS NEEDED:	4 – “D” POLE	3 – 50-TOOTH RATCHET WHEEL
	1 – 4 TH POLE HAND WHEEL	4 – QUICK RELEASE POLE HOOK
	4 – SPRING	4 – NYLON WASHER
	4 – POLE CAP	

- First attach the Quick Release Springs to the ends of the Quick Release Hooks. This is done by slipping the springs over the knob as pictured.
- Place the Quick Release Hook assembly into the slots that are cut into the end of each “D” Pole.
- Next place a plastic Pole Cap onto the end of each “D” Pole. The slotted side of the Pole Cap goes in the inside.

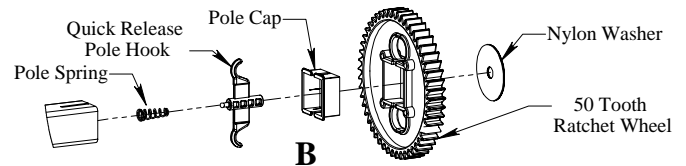

- You will put the ratchet wheel and nylon washer on the end this assembly later.

PART C: Connecting Pole to Pole

PARTS NEEDED: POLES AND 1/4" X 35 MM CONNECTOR BOLTS
 (NUMBER DEPENDING ON WHAT SIZE YOU ARE ASSEMBLING (SEE CHART BELOW))

- First match the rail assembly size with the size you selected for the braces. Look at the chart below to see which poles are needed for the desired size.
- Align the slanted ends of the pole parts together and insert each bolt into the outside hole. Continue inserting the bolt through to the metal T-nut insert.
- Begin all the bolts by hand, then, while holding the wood poles together, align it squarely on all sides. Now use the allen wrench to completely tighten all bolts. Continue bolting together all slanted ends of poles until you have four quilting poles of identical size.

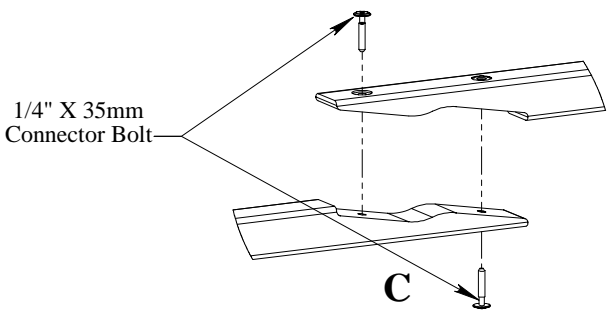

Crib Size: 2 connector bolts per pole assembly **Twin Size:** 4 connector bolts per pole assembly
Queen Size: 2 connector bolts per pole assembly **King Size:** 4 connector bolts per pole assembly
(Multiply the amount of connector bolts x 4 pole assemblies for total needed connector bolts)

POLE ASSEMBLY (BY LENGTH OF QUILTING SPACE)

Quilt must be at least 1" smaller than the overall length of pole.

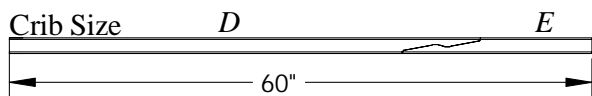

F = 55 1/2
 D = 48 1/2
 G = 22
 E = 19 1/2

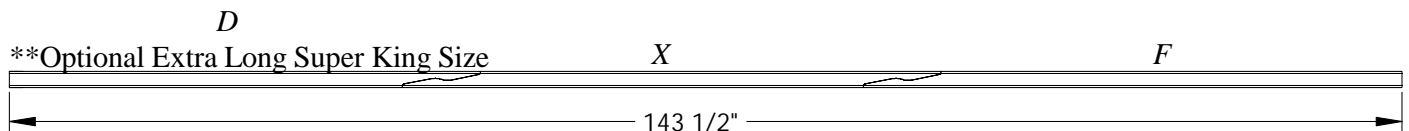
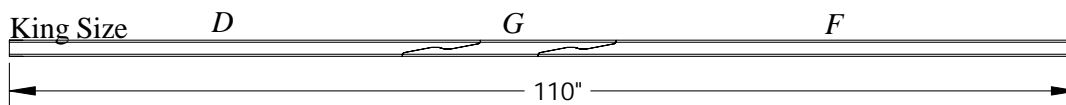
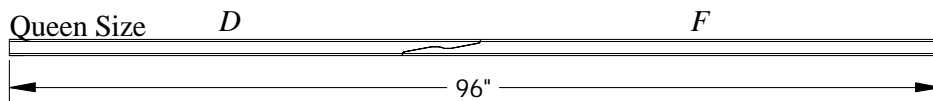
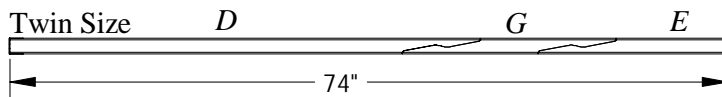

STEP 12: QUILTING POLE TO POLE MOUNT END ASSEMBLY

PARTS NEEDED: 4 – ASSEMBLED POLES
 3 – RATCHET STOPS
 3 – 1/4" X 1 1/2" TRUSS BOLT

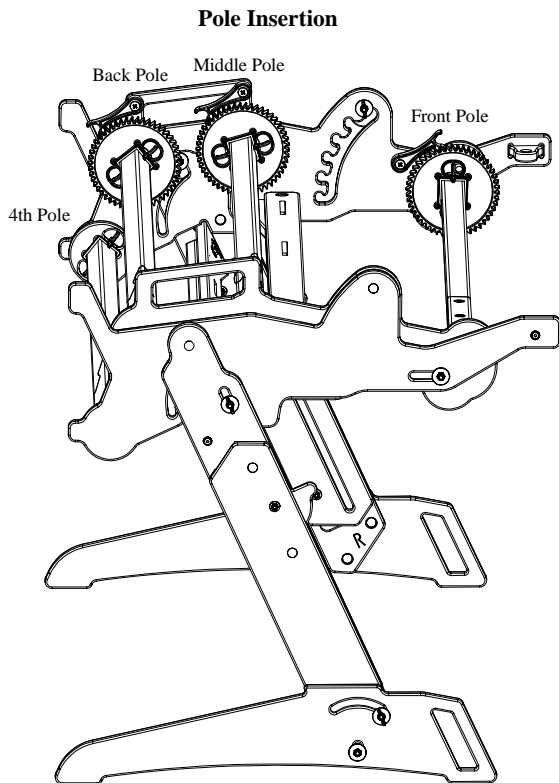

*****IMPORTANT:** Before completing the next step, keep in mind that the truss bolt should be about 1/4" too long. **THE TRUSS BOLT SHOULD NOT BE TIGHTENED WITH ANY TOOL. TO AVOID DAMAGE, TIGHTEN THIS BOLT WITH YOUR FINGERS ONLY.**

- Install the three ratchet stops by threading one truss bolt through a ratchet stop and into a metal insert of the Right Pole Mount End. Be sure they point the same direction as illustrated.
- Next, install the four rails with ratchet wheels.
- TIP! Observe the direction of the Ratchet Wheel teeth as illustrated below and follow this while assembling the quilting poles to the Pole Mount Ends.

- Slip a Ratchet Wheel onto the end of one "D" Pole. Slip a nylon washer onto each end of the pole assembly. Position the end of the pole that **does not have the Ratchet Wheel on it** into the LEFT FRONT HOLE in the Left Pole Mounting End (just inside the lamp holder). (NOTE: There are three hole options giving you slight height adjustment. **Be sure to place each end in the same level hole).**

Pole Assemblies Wheel Direction

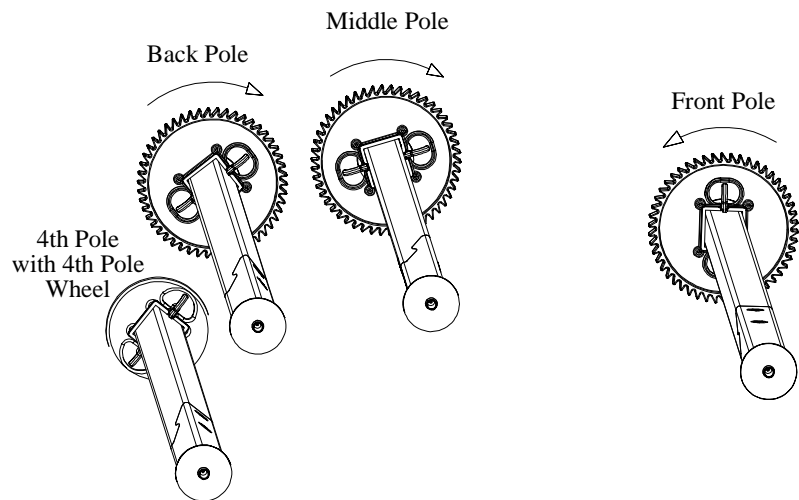

- As you position the Ratchet Wheel end of the pole into the Right Pole Mounting End, pull the Quick Release Hook back, then release it into the hole. (The ratchet stop's teeth should fit snugly into the teeth of the wheel. If it does not, slip the wheel off and flip it around so the teeth go the other direction).
- Complete the above steps for the two other poles with Ratchet Wheels. **Remember, the wheel rotation will be opposite from the wheel on the front pole.**

- Finally, put the lower pole (“4th Pole”) in place, left side first. The right side with the round wheel goes into the round disc already in place on the frame. (**This pole does not have a ratchet wheel.** This is to avoid the possibility of batting tear-out caused by accidental tension).

STEP 13: FINAL FRAME ADJUSTMENTS

- **After all the poles are in place, adjust the Upper Brace so that all the poles will roll freely but will not move much from side-to-side.**
- Tighten the 5/16" hex-head bolts that are in the slots on the Upper Brace.
- **Adjust the Lower Brace so that the tilt action will move smoothly and easily.**
- Tighten the 5/16" hex-head bolts that are in the slots on the Lower Brace.
- Double-check the Brace to Stand Assembly, making sure all connections are completely tightened.

FOLDING AND STORING YOUR Z44™ PROFESSIONAL

Your Z44™ has a tool-free folding process that takes only a couple of minutes. Keep the following things in mind:

- **Frame must be in the horizontal (non-tilted) position before it is to be folded. (See right)**
- After positioning the tilt to the horizontal setting (top notch), re-tighten the tilt-control wing nuts on the Pivot Section (one on each side).
- **The folding feature will not affect the quilt in progress.**
- The depth of the folded frame is about 16".
- **Follow the steps in order, without variation.**
- **Reverse steps to unfold.**
- You can use the WingGrip™ Tool to loosen and tighten your wing nuts! Now you are ready to begin!

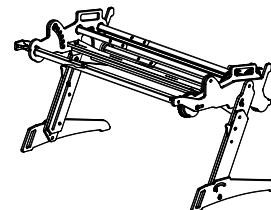

STEP 1: Loosen the wing nuts on the outside Upper Diagonal Stands (one on each side).

STEP 2: Lift the pole assembly up, and allow it to slide down. *When frame is set up in bigger sizes, it is recommended you do this one side at-a-time.*

STEP 3: The pole assembly will drop down until it rests against the diagonal stand (see right).

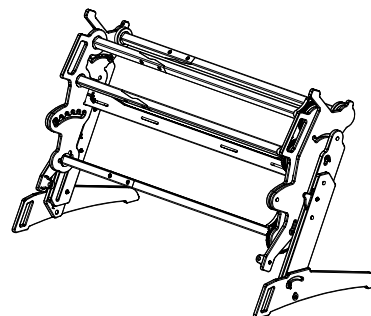

STEP 4: Re-tighten the two wing nuts loosened in Step 1.

STEP 5: Loosen the wing nuts on the Feet (one on each side)

STEP 6: Lift the frame by the Lower Brace until the Feet drop in the slot.

STEP 7: Gently lay frame down and re-tighten wing nuts. (If the Feet do not drop down and fold automatically, or if your frame is set up in a bigger size, *you can fold the Feet manually, one side at-a-time.*)

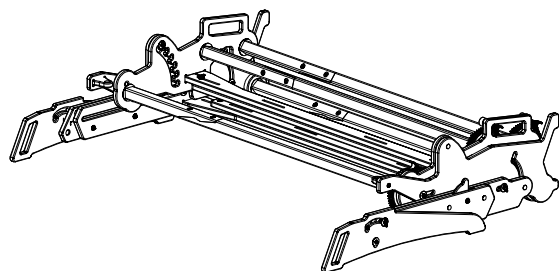

STEP 8: Lifting the frame by the braces, stand the frame on its head as pictured (right) so it can be free-standing.

*****NOTE: IF THE FRAME PARTS DO NOT MOVE AT THE JOINTS SMOOTHLY, CHECK THE NYLOCK NUTS AND MAKE SURE THEY ARE NOT OVER-TIGHTENED.**

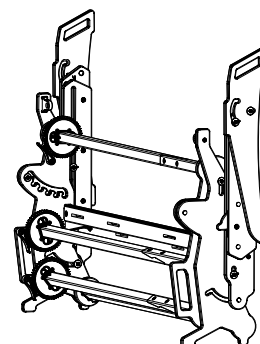

TILTING THE Z44™ PROFESSIONAL

STEP 1: Loosen the wing nuts on the inside of the pivot section (one on each side)

STEP 2: **Standing at the back of the frame**, grip the back or middle pole assembly and pull up and back. This will free the bolts from the ratchet slot. Raise or lower the assembly to the desired angle.

(**NOTE:** For Queen and King size, we recommend adjusting the tilt one side at a time).

STEP 3: Slide Pole Assembly forward again until the bolts on both ends rest completely seated in the slot of tilt arch.

STEP 4: Re-tighten the wing nuts on the Pivot Section.

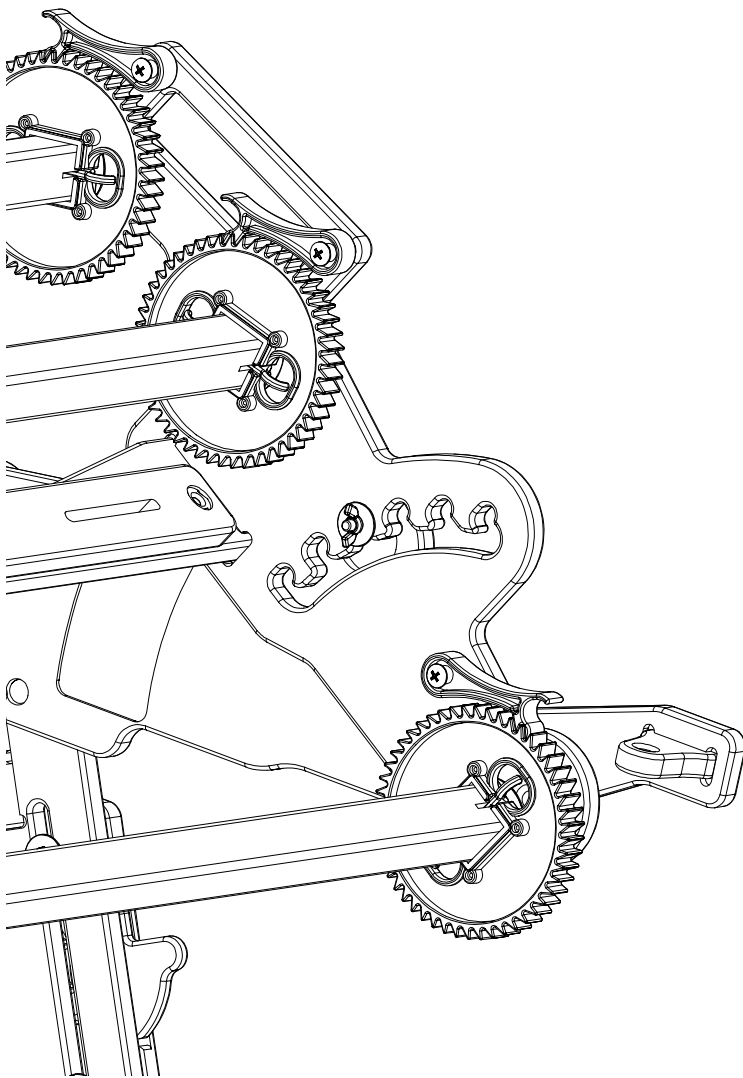

*****NOTE: IF THE FRAME PARTS DO NOT MOVE AT THE JOINTS SMOOTHLY, CHECK THE NYLOCK NUTS AND MAKE SURE THEY ARE NOT OVER-TIGHTENED. ALSO CHECK TO MAKE SURE THE BRACE ARE FITTING SNUGGLY INTO THE END PIECES.*****

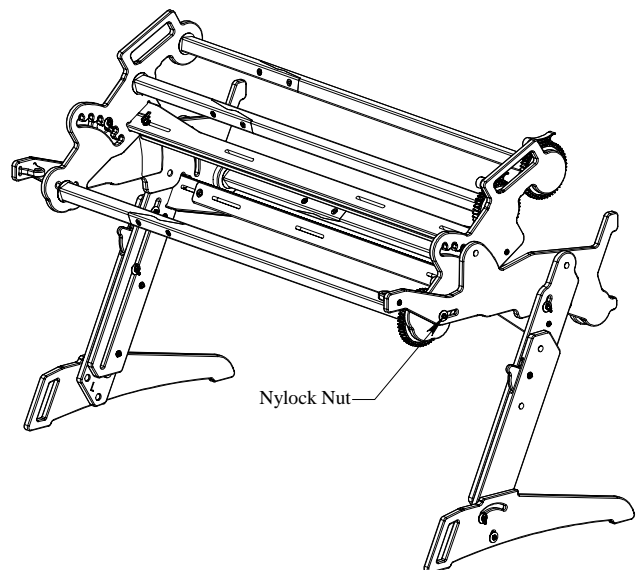
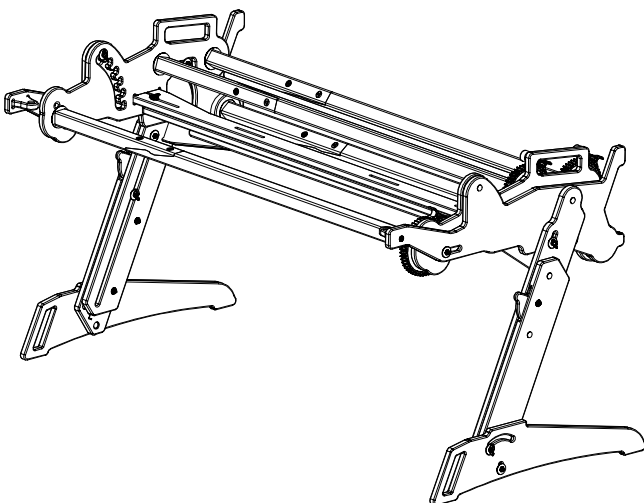

ADJUSTING THE HEIGHT OF THE Z44™ PROFESSIONAL

➤ The Z44™ Professional can be raised or lowered to several different heights. Using this feature, you can adjust the frame to accommodate whatever seating you may be using—even if quilting in a recliner or bed. The frame even raises enough to quilt standing up.

➤ Raising and lowering the frame is done one side at-a-time. Before doing so, be sure to loosen the wing nut on the inside of each Diagonal Stand.

➤ **NOTE!** Only loosen the wing nut just enough to allow free movement of the stands. **Over-loosening may cause the Upper and Lower Diagonal Stand to spread apart and bind during the adjusting process.**

➤ **TO RAISE THE HEIGHT** of the frame, place your foot on top of the foot of the frame. Lift up on the Pivot Section.

➤ You will hear the Height Adjusting Lever click as it passes each height setting.

➤ Count the clicks to make it easier to get both sides to the same height.

➤ Repeat this process on the other side.

➤ **TO LOWER THE HEIGHT** of the frame, place your hand on the Height Adjusting Lever. Push down gently until the Height Set slips into the next setting down. Continue until the frame is lowered to the desired height.

➤ Count the clicks to make it easier to get both sides to the same height.

➤ Repeat this process for the other side.

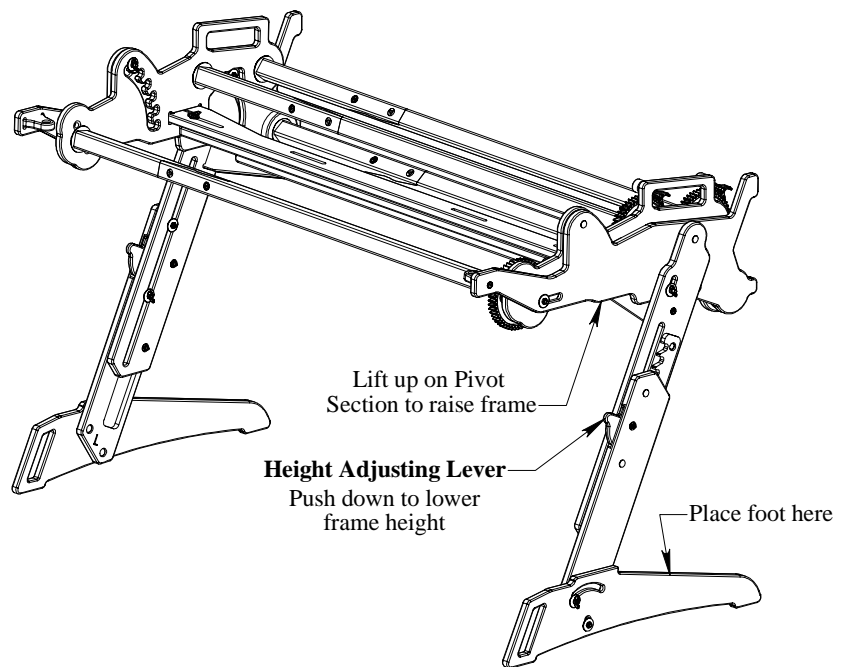
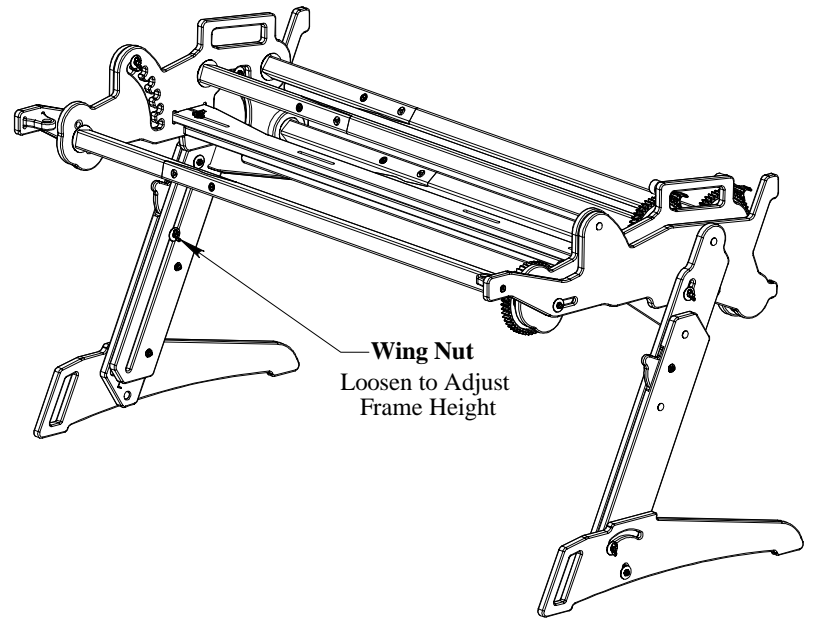

Assembly & Use of Accessories

(Available from the Grace Company: 1-800-264-0644)

Application and Use of EdgeMaster™

- The Edgemaster™ keeps the side tension of the quilting fabric even. Slide the hooks around the back side of the front and middle poles. The bar with the cloth sleeve should rest on top of the two poles, with the sleeve facing toward the work area.
- There are four tightness settings available. The best one will depend on the angle of your poles as they rotate around. (Example: If you are clamping down on the corner of the front pole, you will need to clamp down in a less tight setting).
- To test the appropriate tightness setting, lift the handle up to the unlocked position and move it to a different notch and gently pull down to the locking position. **If it strongly resists locking down, DO NOT FORCE.** The setting is too tight. (typically, the cloth sleeve bar will bend under the pressure of a setting that is too tight).
- Pin the quilt edge to the muslin strip. Next, as you lock in the appropriate tightness setting, pull gently away from the work area to achieve desired side tension. **Do not distort fabric by pulling it too tautly.**

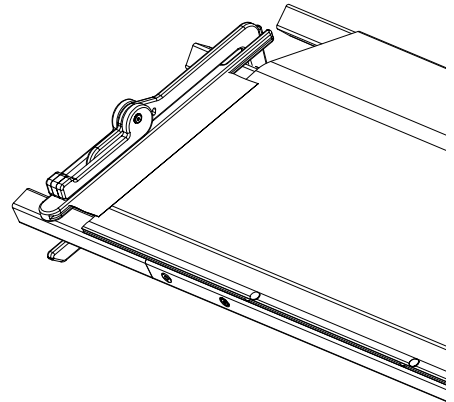
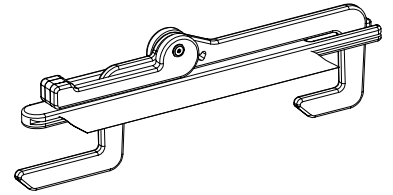

SuperKing™ and Extra Long SuperKing™ Extension Assembly

- These kits extend your frame to 123" (S.K.) and 143" (Extra Long S.K.) to handle over-sized quilts.
- The assembly configuration pictures for the SuperKing™ Extension Pole are located on page 14. The Brace assembly configuration pictures for the SuperKing™ Extension set-up are located on page 17. Follow those pictures and directions as you set up the frame into the SuperKing™ or Extra Long SuperKing lengths.

Super King Extension Kit

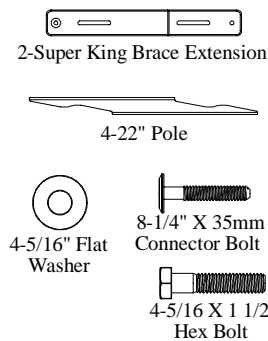

Extra Long Super King Extension Kit

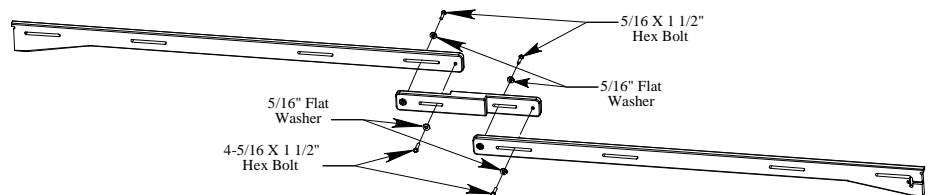
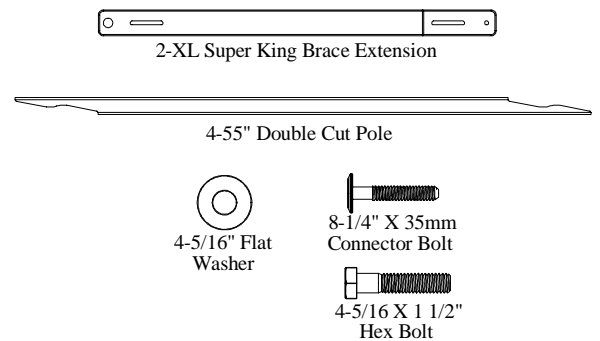

Super King Brace Assembly

The Caster Option

- The Caster Option provides you with special caster-adaptable feet and four lock-able casters (two for each foot).
- Attach these feet to the Diagonal Stand according to the instructions on page 11. The casters come with screws to secure them to the feet.
- Simply push the caster saddle into the pocketed slot on each end of the feet.
- Then push a screw through the hole in the saddle and foot until it comes through the other side.

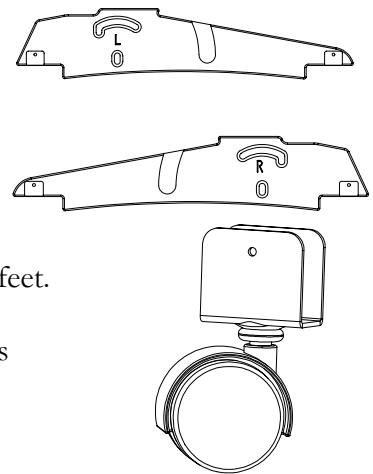

Installing Fabric and Quilting with your Z44™ Professional

Use of *Optional Cloth Leaders*

Your quilt fabrics may be tacked directly to the poles. However, using cloth leaders is a much better way to attach your quilt. Leaders are easy to make and allow the quilter to move the last few inches of the quilt forward from the rear pole to the front quilting area.

This is a suggestion for making one kind of cloth leaders. There are many ways and ideas for making these leaders. Don't be worried about trying your own idea. Just remember that the widest strip of fabric should be applied to the rear pole. This allows the whole quilt to come up into the area of quilting without stopping and adjusting the quilt top to the second pole in order to finish it.

The best cloth selection for making cloth leaders is unbleached muslin.

- Purchase:*
- 1 ½ yards for 58" pole (crib)
 - 2 yards 72" pole (twin)
 - 2 2/3" yards for 94" pole (queen)
 - 3 yards for 108" pole (king)

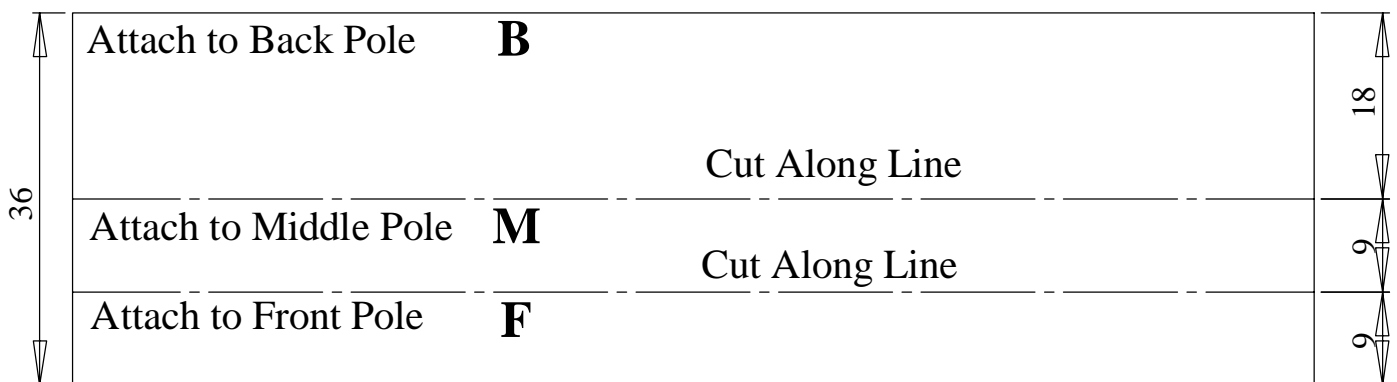

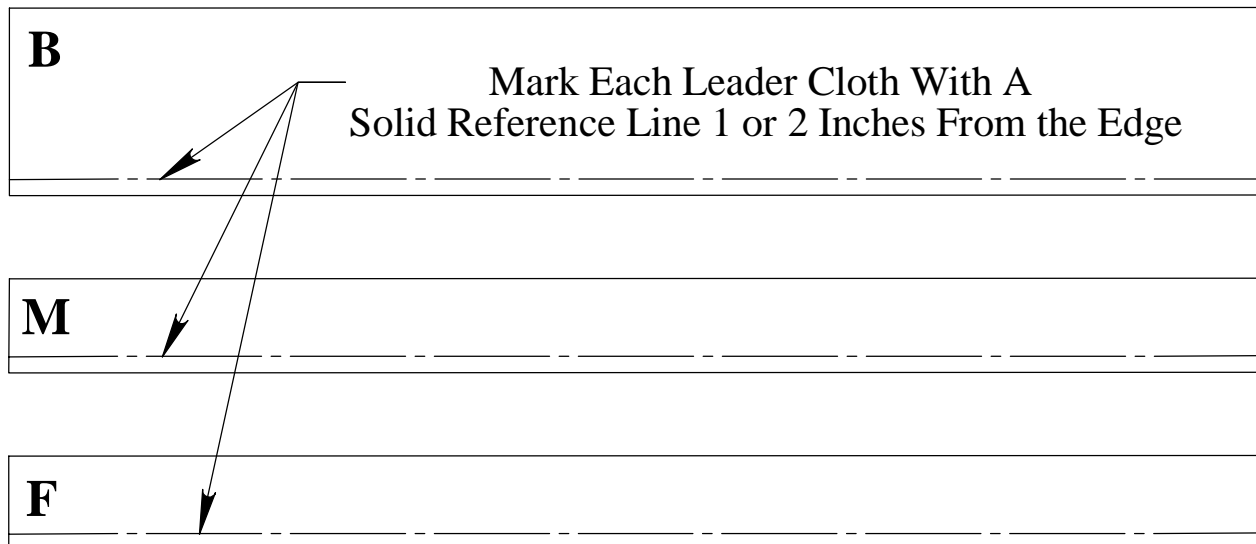

- < **Step 1.** Cut the fabric as shown in illustration above.
- < **Step 2.** Finish the cut edges of the leaders with either a serge stitch or with a very straight 1/2" hem allowance. **Press the leader cloth with a warm iron.**
- < **Step 3.** Draw straight, dark, solid line 1" from one edge of each of the leader cloths.
- < **Step 4.** Thumbtack the cloth leaders to the poles as shown on illustration below.
- < **Step 5.** Pin or baste your quilt fabrics to the cloth leaders. Use the dark, straight line that you marked on your leaders in Step 2 to align your quilt fabrics with.
- < **Step 6.** Roll the Cloth Leaders and Quilt Fabrics up on Poles.
- < **Step 7.** You are now ready to begin quilting.

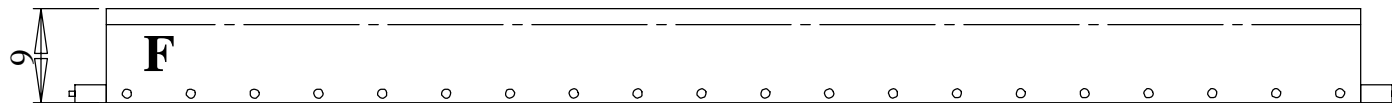
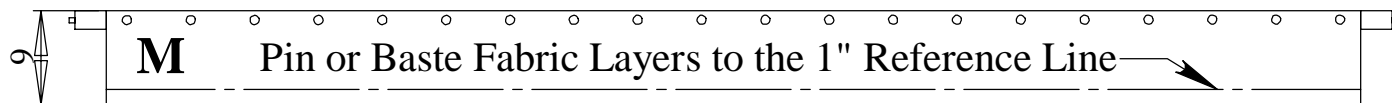
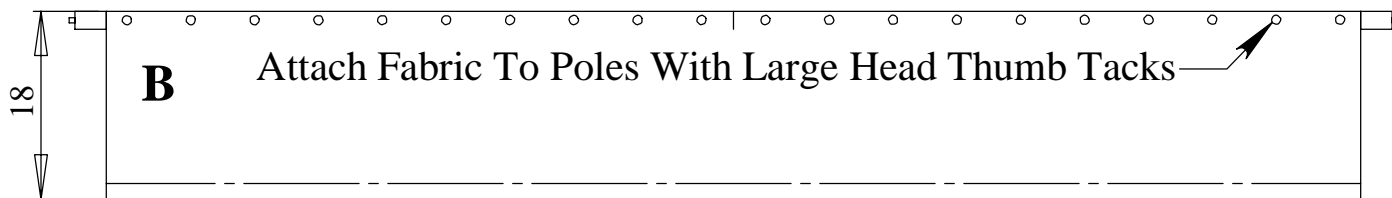

Installing Fabric on the Z44™ Professional

Step 1. BACKING FABRIC

The first fabric that will be applied to the quilting frame is the **Backing**.

The **Backing** is also known as the lining fabric. This piece of fabric will be the under side of the finished quilt. It is recommended that this piece of fabric be 2" to 4" larger than the top on all four sides, especially if your top is a pieced top.

(A pieced top may possibly stretch out and become larger than the backing if you do not make this allowance). The **Backing fabric** can be one continuous piece of fabric or can be made by sewing fabric together.

Piecing the Backing fabric:

Cut the selvages before you piece the back fabric together. The selvedge is woven more tightly than the rest of the fabric and won't have the same "give" as the rest of the fabric which can cause the seam to be too tight. Use a slightly larger machine stitch than used in normal sewing when piecing the lengths of the back fabric together. Many quilts have **Back fabrics** that are not one continuous piece of fabric and are pieced together using two fabric pieces with a seam down the middle or three fabric pieces with two seams having been sewn. You can also sew your back fabrics together using crosswise piecing.

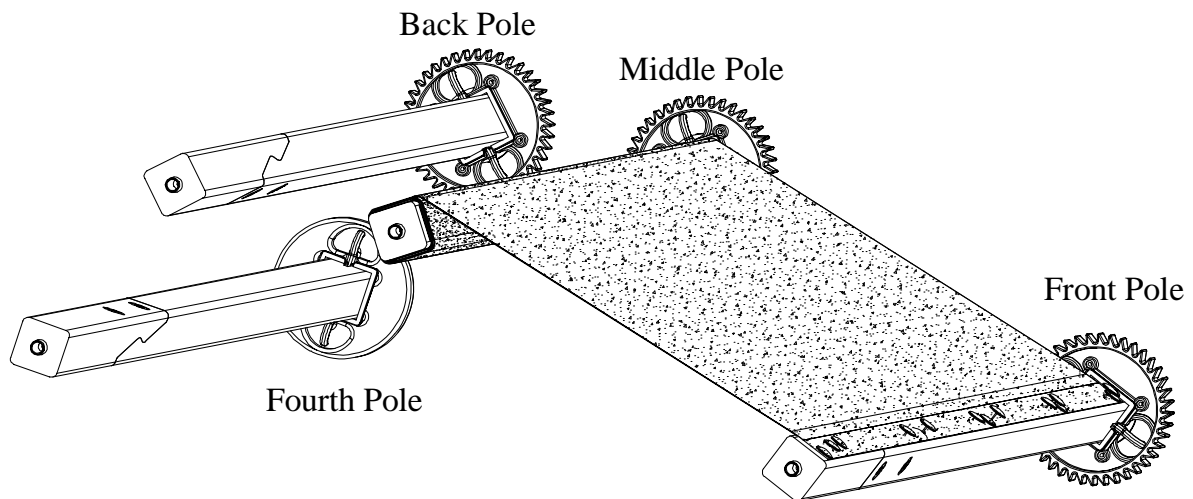

Front Pole-Backing fabric

1. Mark the center of **Backing fabric** with a pin or a pencil mark.
2. Tack the center mark to the center of the front pole. (The **Backing fabric** is put on with the wrong side of the fabric up and visible.)
3. Lay the fabric naturally and evenly along the straight edge of the pole. **Do not stretch the fabric**. Tack the corners of the fabric to the pole.
4. Add a few more tacks to hold the material on the pole.

Middle Pole–Backing fabric

1. Tack the other end of the **Backing fabric** to the middle quilting pole, centering with the mark as directed on the front pole.
2. Tack the center mark to the center of the middle pole.
3. Lay the fabric naturally and evenly along the straight edge of the middle pole. Do not stretch the fabric. Tack the corners of the fabric to the pole.
4. Measure the amount of wood showing at the edges of the fabric to the end boards. This measurement should equal the amount showing on the front pole.
5. Securely tack the **Backing fabric** along the entire edge of the middle pole, using plenty of tacks.

Rolling the Backing fabric onto the middle pole

1. Roll the material onto the middle pole, making a smooth roll. Be sure there are no wrinkles present.
2. Smooth the quilt from the center to the outside edges of the pole as it is being rolled. **At this point do not roll the fabric tightly, just roll it nicely smooth and even.**
3. Roll until there is very little slack between the two poles.

Now, from the front of the frame, look at the fabric and readjust the fabric on the front pole if necessary. Sometimes, due to an uneven grain line of the fabric, the fabric will be loose in one area and tighter in another. First, try rolling the fabric completely from the middle pole to the front pole and then back to the middle pole again. Then if this did not adjust the fabric, simply even the tension by adjusting the tacks on the front pole. After adjusting the tension add additional tacks to hold the fabric on the front pole.

Step 2. BATTING INSTALLATION

1. Center the **batting** on the front pole over the **backing** and tack down with a few tacks. Smooth **batting** over the back to the middle pole and let the **batting** drape to the floor between the **middle pole and the 4th pole**.

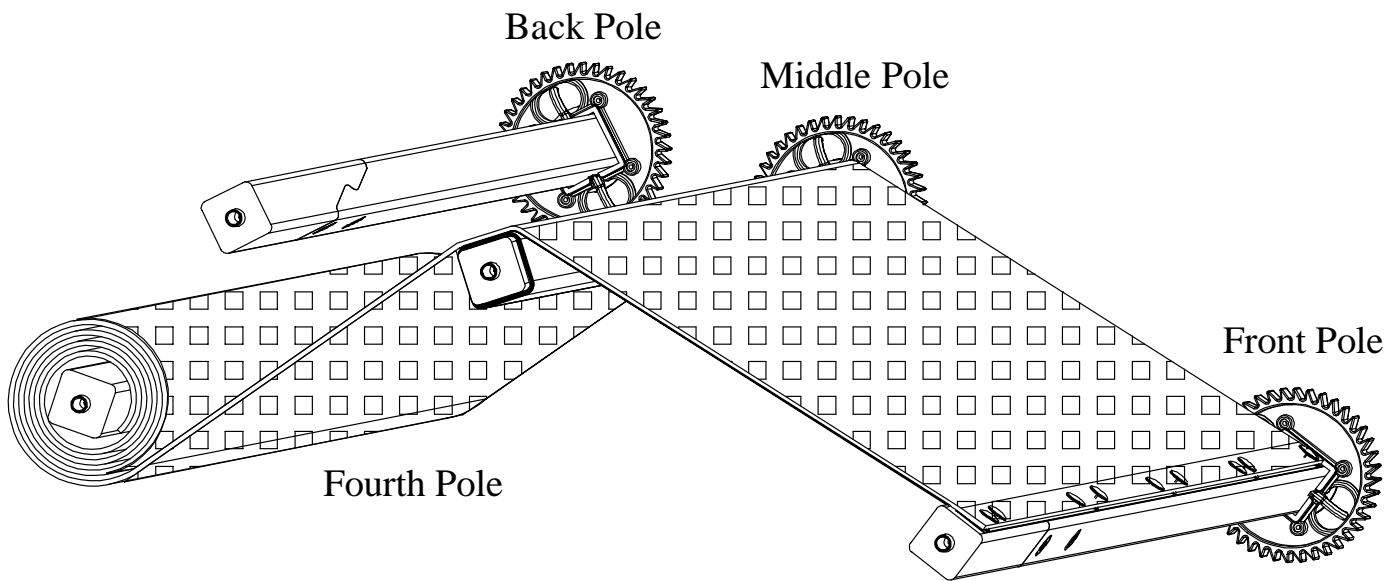

2. At this point, leave the batting draped to the floor. You will roll it onto the fourth pole after applying the quilt top.

Step 3. QUILT TOP

1. Tack the center of the quilt top onto the center of the front pole.
2. Smooth out the quilt top from the center to each corner. **DO NOT STRETCH.**
3. Tack the quilt top along the straight edge of the pole over the backing and the batting layers.
4. Drape the quilt top over the middle pole and let it hang between the middle and rear poles.
5. Tack the center of the quilt top edge to the rear pole.
6. Smoothly and evenly, without stretching, tack the fabric to the rear pole moving from the center to each corner.

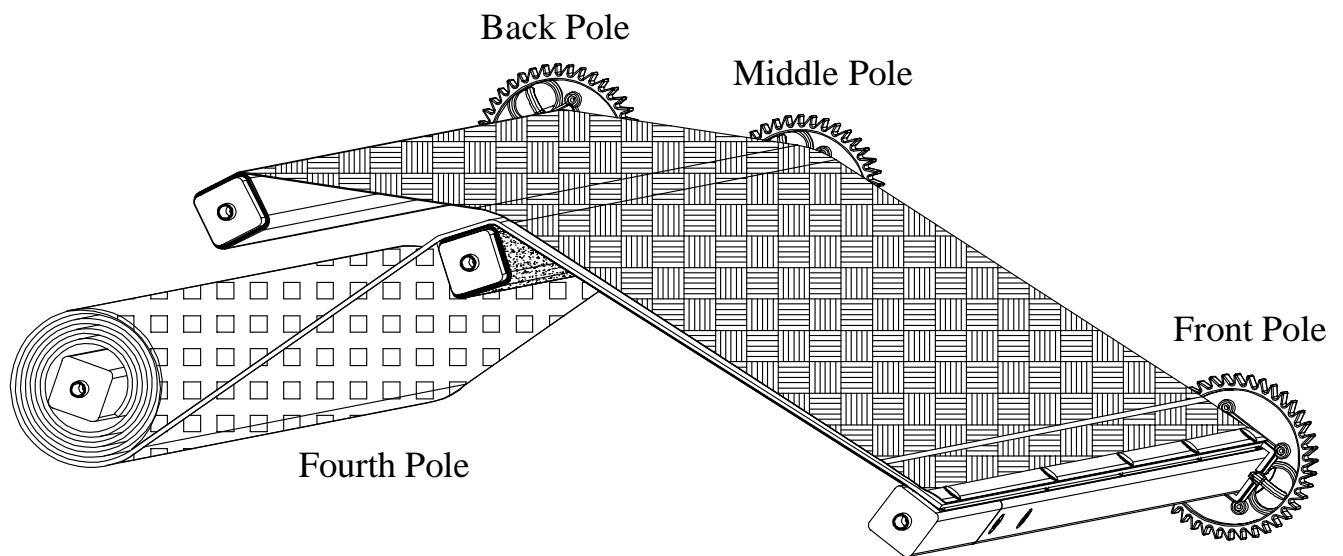

7. Measure the quilt top edge to the end boards. This measurement should be the same distances as on the front pole.

8. Roll the quilt top onto the rear pole. Keep this roll smooth and loose, without allowing any wrinkles or creases to occur.

9. Now adjust the tensions of quilt top and backing fabrics until you get the desired tension. Adjust the tightness of the fabrics by turning the cog wheels by hand. **DO NOT OVER TIGHTEN.** Apply the cog stop to the cog wheels.

10. Begin quilting from the front edge and roll as you go.

Happy Quilting!

Trouble Shooting

Problem: Fabric sags on one side or in middle.

Solution: Fabric may not be cut evenly straight or the grain of the cloth may not be square. Take it off and square it up or pull (gently) to square.

Problem: Sides of quilt have a concave edge.

Solution: The fabric was stretched along the pole. Take the fabric off and let it relax until it is not misshapen and then re-install, without stretching it along this edge.

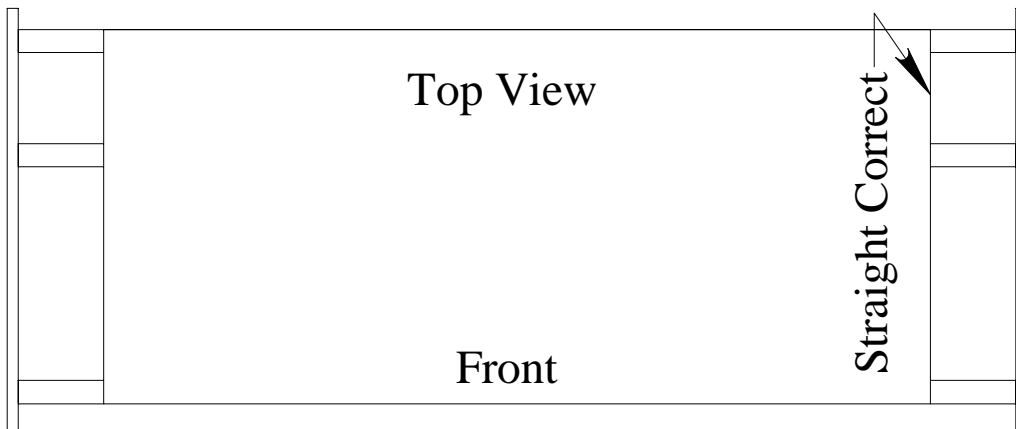
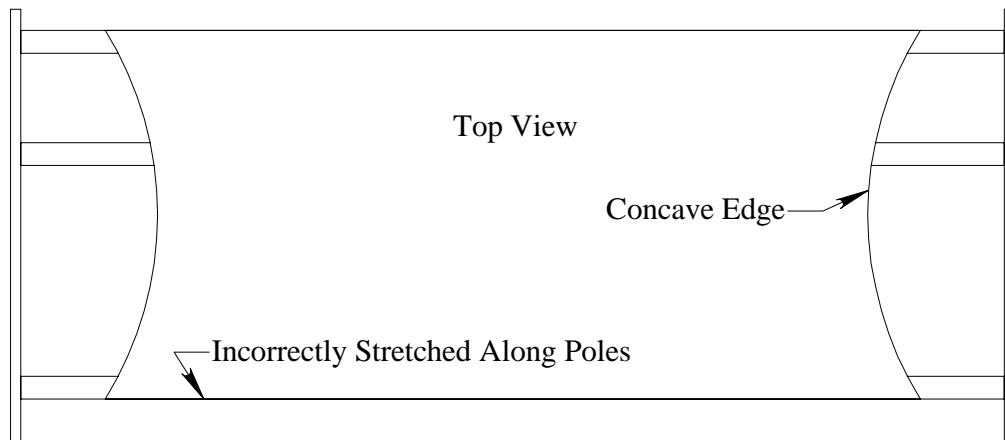

Problem: Quilt backing is much longer than quilt top, after quilting.

Solution: Monitor tension of backing and quilt top. Mark on edges of fabrics every six inches on backing and quilt top and as you roll you will be able to monitor the tension.

Problem: Batting tears or separates during the tightening of the cogwheels.

Solution: The batting was stretched and stressed. The batting should be longer than the quilt that you are making and there should not be tension applied to it. Check the 4th pole to make sure that it is rolling smoothly and easily.

Problem: Poles are bowing in.

Solution: The causes may be: 1. Seam down the center of the fabrics may be sewn too tight and is not giving with the rest of the fabric. If the seam is the problem the quilt may be attached sideways. 2. Fabric is not cut evenly. 3. Too much tension has been applied. 4. Fabric has been stretched along the poles instead of smoothly laid along the pole then attached.

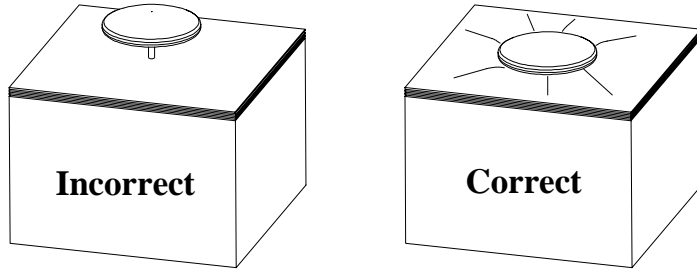

Problem: Fabric pulls/tears out at the thumbtacks when tension is applied.

Solution: Seat the tack all the way in. The head of the tack, not the post of the tack, should hold the fabric. Use a tack hammer to seat the tacks if your hand is not strong enough.

Problem: Poles squeak as they roll or they do not roll freely.

Solution: **The frame is not square!** Square it up with the floor using a carpenter's square or an uncut piece of poster board or a picture frame. If the quilting frame still squeaks after making sure that the frame is in good square alignment, rub some paraffin or candle wax on the dowel ends of the poles.

Helps for Quilting, and Especially Tying:

Before installing the quilt onto the frame, mark both the quilt top and backing in similar increments **along the two side edges**. (The sides that are not tacked onto the poles). While rolling the quilt during the tying process watch the marks. This will help you to keep an equal tension on the top and backing fabrics so you won't over tighten one or the other of your fabrics.

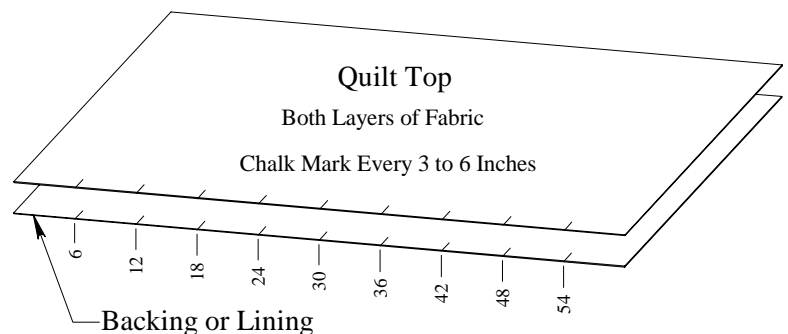

When rolling into a new area of tying, allow your last row of ties to remain in the new area of tying. Also, tie your knots tight. **Do not roll past you last row of ties.**