

The Grace Z44™ Professional

Quilting System

Table of Contents

Care, Finishing and Storage

Warranty

Parts Lists

Assembly

Step 1: Hardware to Diagonal Stands.	1
Step 2: Hardware and LampHolders to Pivot Sections.	1
Step 3: Hardware to Pole Mounting Ends.	2
Step 4: Base Feet and Pivot Sections to Diagonal Stands.	2
Step 5: Pole Mounting Ends to Pivot Section Assembly.	3
Step 6: Pole Mounting Ends to Diagonal Stands.	4
Step 7: Brace Assembly.	5
Step 8: Brace to Stand Assembly.	7
Step 9: Quilting Pole Assembly.	8
Step 10: Quilting Pole to End Assembly.	10
Step 11: Final Frame Adjustments.	10
Tilting your Z44™ New Millennium.	11
Folding and Storing your Z44™ New Millennium.	12
Accessory Assembly.	13
Quilting Instructions and Tips	
How to Use Your GraceFrame (Fabric Installation).	14
Making and Using Optional Cloth Leaders.	16
Trouble Shooting	17
Tying Quilts.	18

Copyright November 2001 Jim M. Bagley
GraceWood, Inc. Reproduction Prohibited
Patent Pending

For Missing or Damaged Parts; Do not contact your
store or dealer. Call the Grace Company Direct!
(1-800-264-0644)

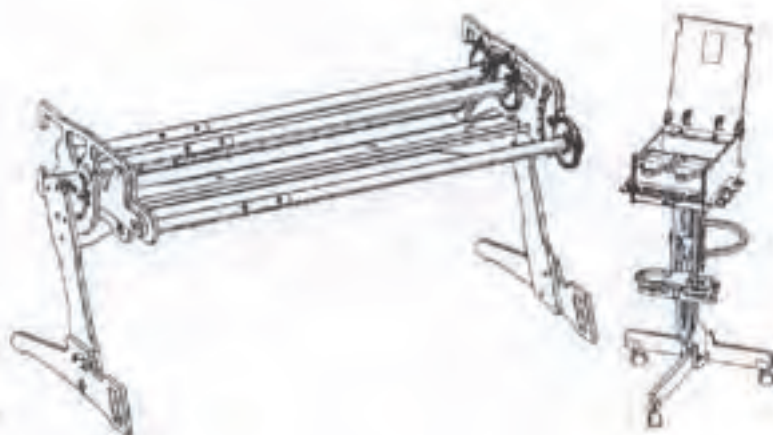

Caring for Your Z44™ Professional

Your Z44™ Professional can be used unfinished. For extra protection, or to give it a finished look, you may seal, stain and/or finish the frame using a number of different applications. This is best done BEFORE YOU ASSEMBLE your frame.

To seal the wood, we recommend an application of tung oil which will help preserve the wood and will help to prevent warping. To add a certain color to your frame, you may use a Danish Oil finish. We recommend the Defl™ or Watco™ brands. Some prefer to use a urethane coat to add a glossy finish.

Test your stain on an inconspicuous place. Many different finishes and/or stains may be suitable for sealing and beautifying your frame. You may want to consult your local paint retailer for finishes which are easy to apply and dry hard-not oily.

Use and Storage Tips

—Store frame in a dry place if not assembled, preferably with poles and braces in vertical position. (This will prevent floor moisture from seeping into the poles).

—Do not carry the assembled frame by the quilting poles.

—Do not drop the frame or let it twist out of square.

Warranty

*Warranty card must be filled out and sent to: **GraceWood, Inc.**
P. O. Box 27823
Salt Lake City, Utah 84127*

GraceWood, Inc. will replace or repair, at our choosing, any part of the Grace Z44™ Professional Quilting Frame, which may be shown to be defective. This Lifetime Warranty does not cover parts damaged through misuse, improper storage, improper assembly, loss, natural events and willful or accidental destruction. Defective parts may be returned only with a valid RMA# which may be obtained by calling GraceWood, Inc. at (801) 485-6688. Warranty registration card must be returned within 30 days of purchase.

For correspondence concerning your Z44™ Professional, write to:

The Grace Company

P.O. Box 27823

Salt Lake City, UT 84127

For shipping of materials to the Grace Company address package (postage prepaid) to: The Grace Company, 801 West Layton Avenue, SLC, UT 84104. Materials may be returned only with a valid RMA# (Returned Merchandise Authorization Number) which may be obtained by calling GraceWood, Inc. at (801) 485-6688.

For technical support, call (801) 485-6688. All calls will be returned. Please report any errors in these instructions or make constructive comments to the following:

Fax: (801) 485-4388 – E-mail: info@graceframe.com – <http://www.graceframe.com>

About the Grace Quilting Frame

The Grace Quilting System has been developed over the past decade with several original design innovations. Due to feedback from many of the thousands of quilters who have purchased and use the GraceFrame™, we have been able to make a frame that will truly enhance the entire process of hand quilting from beginning to end. If you have any suggestions that will help us to improve our product or service, please write to The Grace Company.

Large Parts List

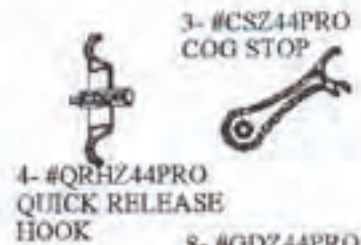
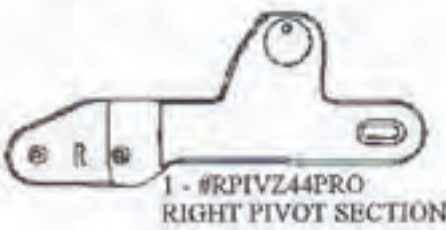
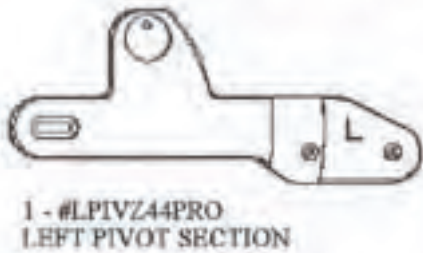
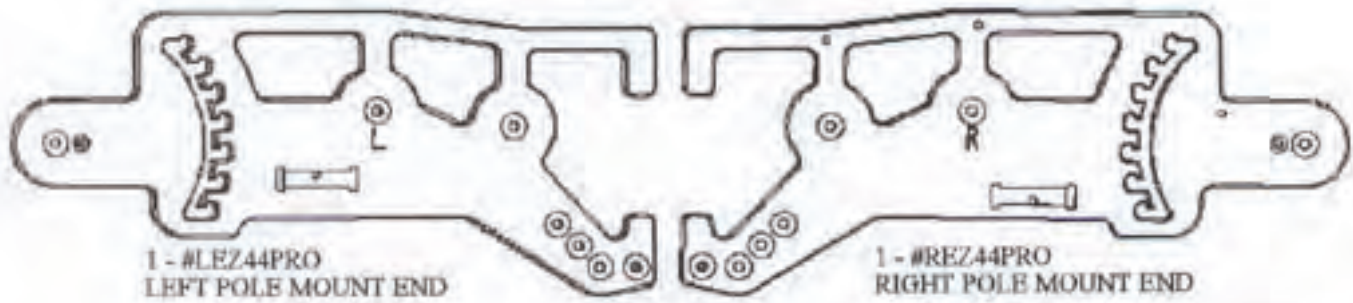

3 - #CSZ44PRO
COG STOP

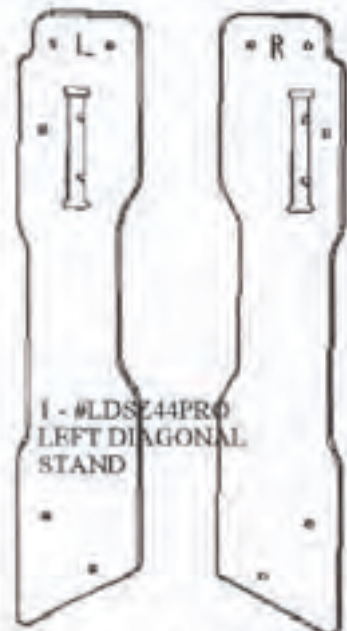

8 - #GDZ44PRO
GUIDE DOWEL



1 - #WGZ44PRO
WING GRIP TOOL

1 - #RDSZ44PRO
RIGHT DIAGONAL
STAND



1 - #LTHZ44PRO
LEFT TILT HEAD



1 - #RTHZ44PRO
RIGHT TILT HEAD



3 - #CWZ44PRO
COG WHEEL



2 - #UPBRZ44PRO
UPPER BRACE



2 - #LOBRZ44PRO
LOWER BRACE

Small Parts List



6 - 5/16" x 2"
Carriage Bolt



6 - 5/16" x 1 3/4"
Carriage Bolt



4 - 5/16" x 1 1/2"
Hex Head Bolt



6 - 1/4" x 60mm
Connector Bolt



25 - 1/4" x 35 mm
Connector Bolt



8 - 1 1/8" Grabber
Screws

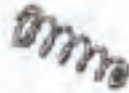

4 - Springs



6 - 5/16"
Wing Nuts



6 - 5/16" Nylon
Lock Nuts



12 - 5/16"
Jamb Nuts



6 - 1/4"
Rectangle Nuts



1 - Allen Wrench



8 - Plastic Washers



12 - 5/16" x 1 1/2"
Fender Washers



4 - 5/16" Flat
Washers



12 - 1/4" Flat
Washers



14 - 5/16" Plast
Rollers

4 - #PL55-5Z LARGE POLE EXTENSION **F**

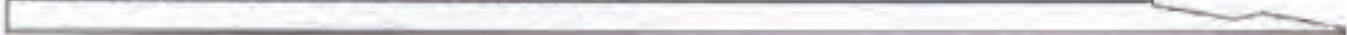

4 - #PL48-5Z SPRING END POLE EXTENSION **D**



4 - #PL22-0Z DOUBLE END POLE EXTENSION **G**



4 - #PL19-5Z SMALL POLE EXTENSION **E**



*****OPTIONAL PARTS*****

OPTIONAL SUPER KING PARTS LIST

- 4 - PL22-0Z DOUBLE END POLE EXTENSION "G"
- 8 - 1/4" 35MM CONNECTOR BOLTS
- 4 - 5/16" X 1 1/2" HEX BOLTS
- 4 - 5/16" FLAT WASHERS

1 - #UP215SKZ UPPER BRACE EXTENSION



1 - #LO22125SKZ LOWER BRACE EXTENSION



OPTIONAL EXTRA LONG SUPER KING PARTS LIST

- 8 - 1/4" 35MM CONNECTOR BOLTS
- 4 - 5/16" X 1 1/2" HEX BOLTS
- 4 - 5/16" FLAT WASHERS

1 - #UP4125SKZ-XL UPPER BRACE EXTENSION



1 - #LO4175SKZ-XL LOWER BRACE EXTENSION

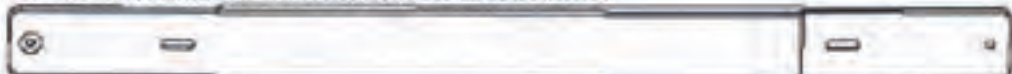

4 - #XL.SKPL.55-5Z DOUBLE END POLE EXTENSION "X"

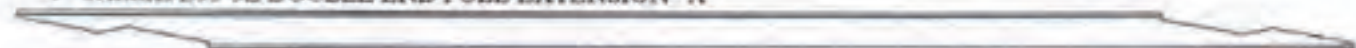

Assembly of The Z44™ Professional

Before You Begin

Using the parts list as a reference, take the parts out of the box and make sure your package is complete. (If there is something missing or damaged, do not call the store or dealer from whom you purchased the product. Contact The Grace Company directly: 1-800-264-0644).

Tools Needed

To assemble your frame, you will need the following common tools:

1. One 1/2" wrench
2. One 7/16" wrench (a combination or socket wrench is preferable)
3. Phillips Head Screw Driver
4. WingGrip™ Tool (provided)
5. Alan Wrench (provided)

Note: To help you distinguish between wood parts, all Left Side parts are marked with an "L" grooved into the wood on the inside of the part. Right side parts are also marked with an "R" on the inside.

Step 1: Hardware to Diagonal Stands

Parts Needed: Right and Left Diagonal Stands
4 - 5/16" x 2" Carriage Bolts
4 - Jamb Nuts
4 - 1/4" Flat Washers (Smaller)
4 - Plastic Rollers

- Note the direction carriage bolts go through the parts.
- Tighten jamb nuts on carriage bolts to pull the square part of the bolts into the wood until they are completely seated into the parts.
- Slide a plastic roller onto each of the carriage bolts. These will fit loosely and will be held in place by the parts assembled in Step 5. Be sure they stay in place as directed.

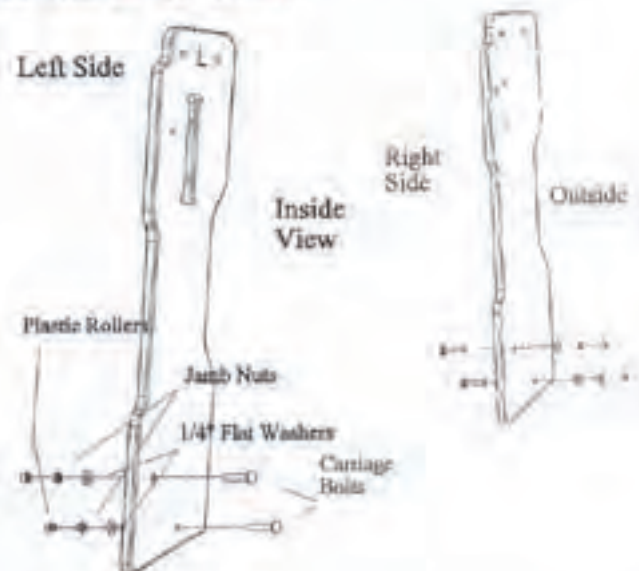

Step 2: Hardware to Pivot Sections

Parts Needed: Right and Left Pivot Sections
2 - 5/16" x 2" Carriage Bolts
4 - 5/16" x 1 3/4" Carriage Bolts
6 - Jamb Nuts
6 - 1/4" Flat Washers (Smaller)
8 - Plastic Rollers

- Note the direction carriage bolts go through the Pivot Sections.
- Position carriage bolts through pivot sections as shown in drawing. (Longer ones in the top hole, shorter ones in the two bottom holes). Tighten jamb nuts onto the

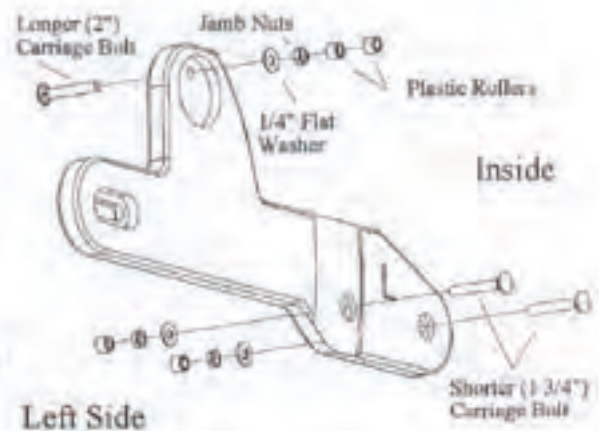

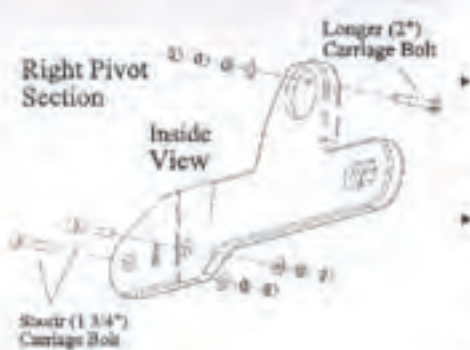

carriage bolts until the square part of the carriage bolt is drawn and seated into the wood.

- Place two plastic rollers on each of the top carriage bolts of the left and right sides, and one plastic roller on each of the remaining four carriage bolts.
- The plastic rollers will fit loosely on the bolts until they are held in place by the parts assembled in Step 5.

Step 3: Hardware to Pole Mounting Ends

Parts Needed: Right and Left Mounting Ends

2 - 5/16" x 1 3/4" Carriage Bolts (Shorter)

2 - 1/4" Flat Washers (Smaller)

2 - Jamb Nuts

2 - Plastic Rollers

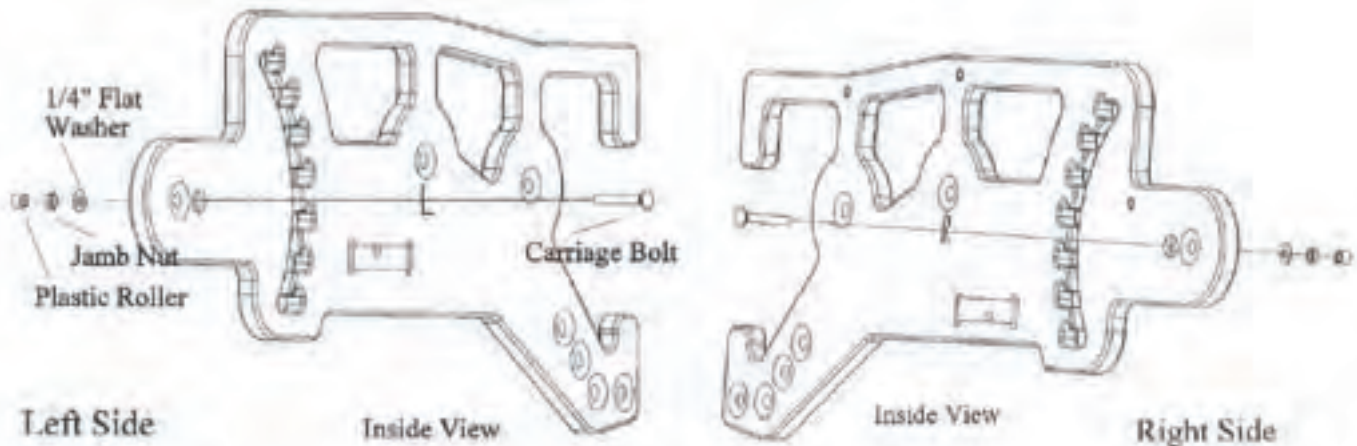

- Note the direction carriage bolts go through the part.
- Tighten nuts on carriage bolt to pull the square part of the bolt into the wood until the bolt is completely seated into the part.
- Slide the plastic rollers on the bolts as pictured. These will rest on the bolt loose and be held in place by the Diagonal Stands (Step 5).
- ***IMPORTANT:** Before proceeding, go back and make sure all jamb nuts are completely tightened! Failure to fully tighten will cause difficulty in later steps.

Step 4: Tilt Heads to Diagonal Stands

Parts Needed: Right and Left Tilt Heads

Right and Left Diagonal Stands

6 - Connector Bolts 35mm (shorter)

1 - Allen Wrench

- Note the proper positioning of the Tilt Heads (T-nuts and "L" and "R" face inside).
- Place the connector bolts through each of the three top holes of the Diagonal Stands (as pictured). Using the Allen Wrench, completely tighten the bolts into the corresponding T-nuts.

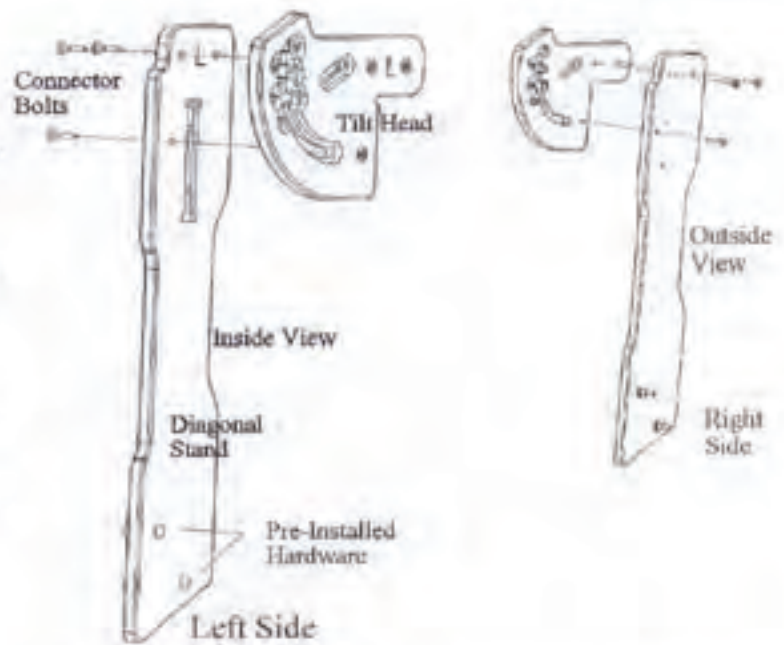

Step 5: Pivot Sections and Base Feet to Diagonal Stands

- Parts Needed: Right and Left Base Feet, Right and Left Pivot Sections (w/ Hardware Installed)
 Right and Left Diagonal Stand Assemblies
 4 - Wing Nuts
 4 - Nylon Lock Nuts
 8 - Large Fender Washers

- Before proceeding, be sure the plastic rollers previously installed on the Pivot Sections and Diagonal Stands remain in place.

Pivot Sections



- Align the carriage bolts that are already installed on the Pivot Sections and the Diagonal Stands through the holes as shown on the pictures.
- The Pivot Section is fastened to the inside of the Tilt Head with the two carriage bolts that protrude from the outside of the Pivot Section. One goes into the ratchet slot, the other into the rectangular slot.
- Place a fender washer on the end of each carriage bolt.

- The carriage bolt in the ratchet slot receives wing nut. Thread a nylon lock nut onto the other bolt, and partially tighten.
- ****Nylon side of nylon lock nuts faces out when threading onto the bolt end.****
- ****When tightening the nylon lock nuts, leave them loose enough to spin the washer and slide the joint.****

Base Feet

- As shown in drawings, position carriage bolt ends through holes in base legs.
- For ease of tightening, thread fender washer and nylon lock nut onto the bottom carriage bolt first.
- Next, thread the washer and wing nut on the top carriage bolts.

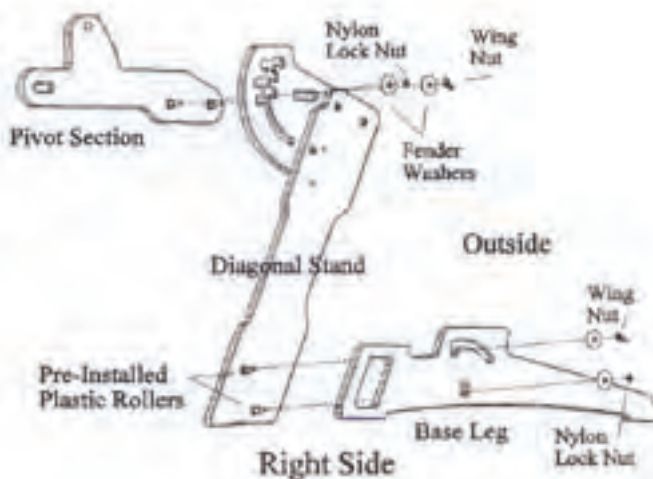

Step 6: Pole Mounting Ends to Diagonal Stand Assembly

Parts Needed:

- Right and Left Diagonal Stand Assembly
- 4 - Large Fender Washers
- 2 - Wing Nuts
- 2 - Nylon Lock Nuts

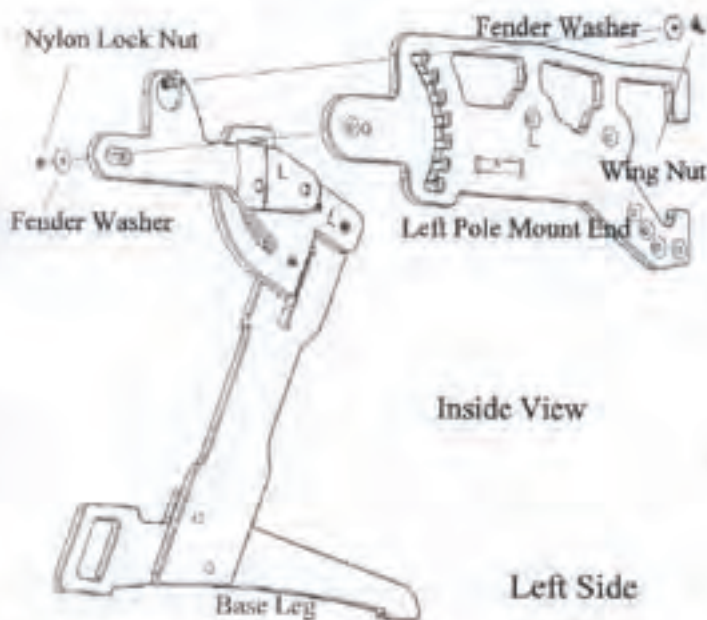

Before beginning, be sure the plastic rollers are in place on the carriage bolts as directed in Steps 2-3.

The carriage bolt in the Pivot Section goes into the ratchet slot of the Pole Mounting End.

The Pole Mounting End's carriage bolt fits into the horizontal slot (next to the "L" or "R") in the Pivot Section.

With the End pieces fastened, place a large fender washer onto both carriage bolts.

- Thread a wing nut on the top (inside) carriage bolt (ratchet slot).
- Thread a nylon lock nut on bottom carriage (outside) bolt.
- **Nylon side of nylon lock nuts faces out when threading onto the bolt end.****
- **When tightening the nylon lock nuts, leave them loose enough to spin the washer and slide the joint.****

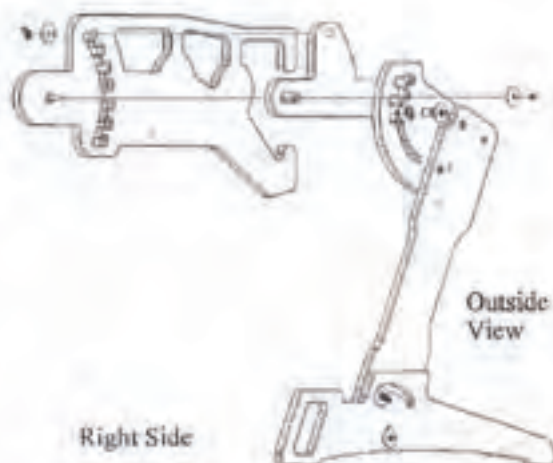

Step 7: Brace Assembly

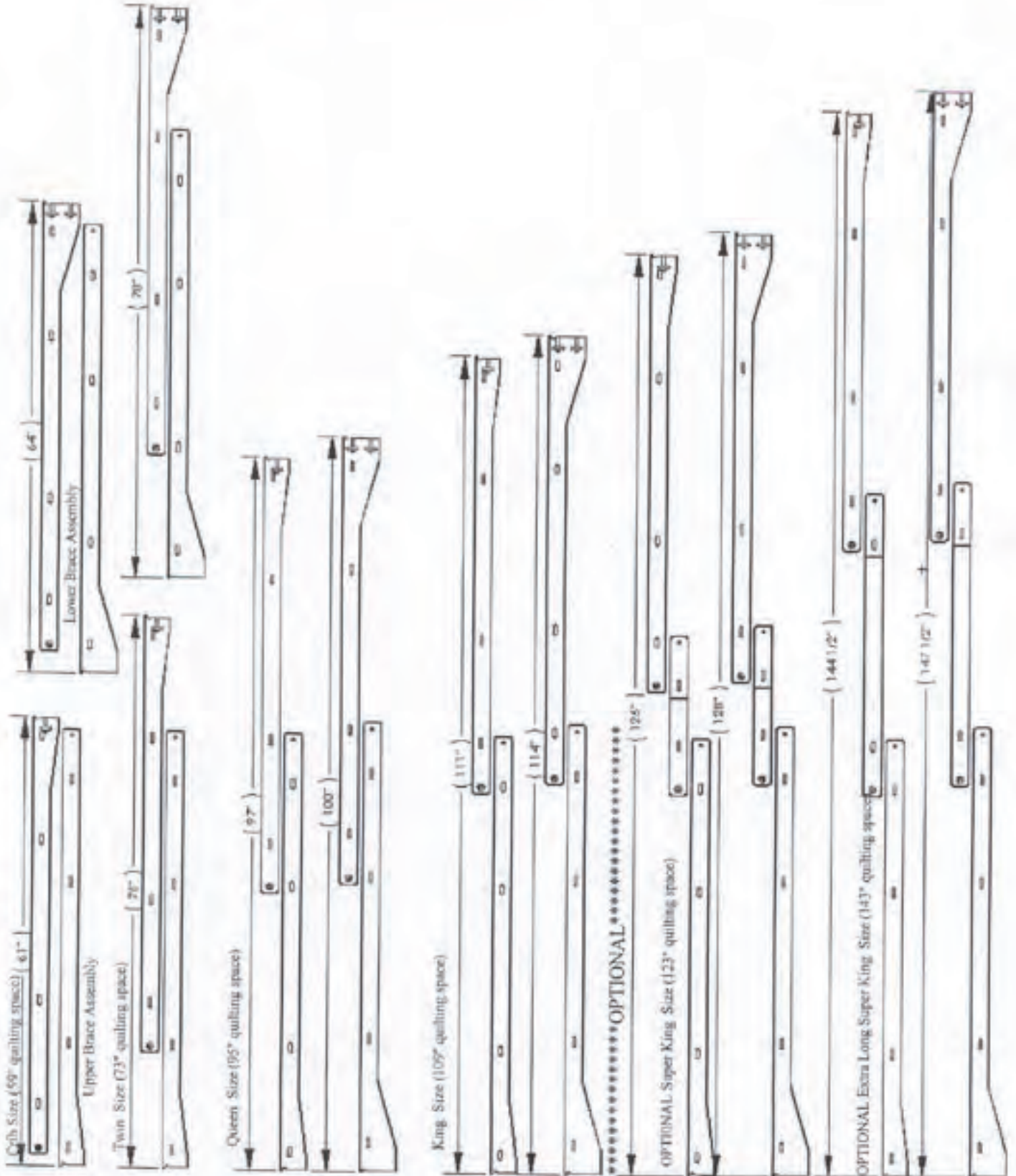

Step 7: Brace Assembly (con't)

- Parts Needed: 2 - Upper Braces
- 2 - Lower Braces
- 4 - 5/16" x 1 1/2" Hex-Head bolt
- 4 - 5/16" Washer (Larger)

NOTE: WHEN PAIRING UP YOUR BRACES, THE GOLD INSERTED METAL T-NUTS MUST ALWAYS FACE OUTSIDE AND BE VISIBLE AFTER ASSEMBLY IS COMPLETE. FAILING TO DO THIS WILL CAUSE THE T-NUTS TO LOOSEN AND EVENTUALLY FALL OUT!

- * **TIP** - Be sure to pair upper brace to upper brace and lower to lower.
- Decide which size quilt frame you want to put up (see sizes in diagram of previous page).
- Follow the line up of holes as indicated in the pictures according to the size of the frame that you are assembling. Notice the position of the inserted metal T-Nuts. Be sure they are facing outside.
- Put the 5/16" washer on the 5/16" x 1 1/2" bolt and start it through the slot first, continuing through the round hole into the inserted metal T-nut.
- By hand, begin to tighten all the bolts onto the threads of the T-nuts. Do not tighten the bolts with a socket wrench at this point. Leave them loosely holding the parts together. (They will not be completely tightened until the poles are installed).
- * **TIP** - Double check to be sure the metal T-Nuts are visible, facing outside.

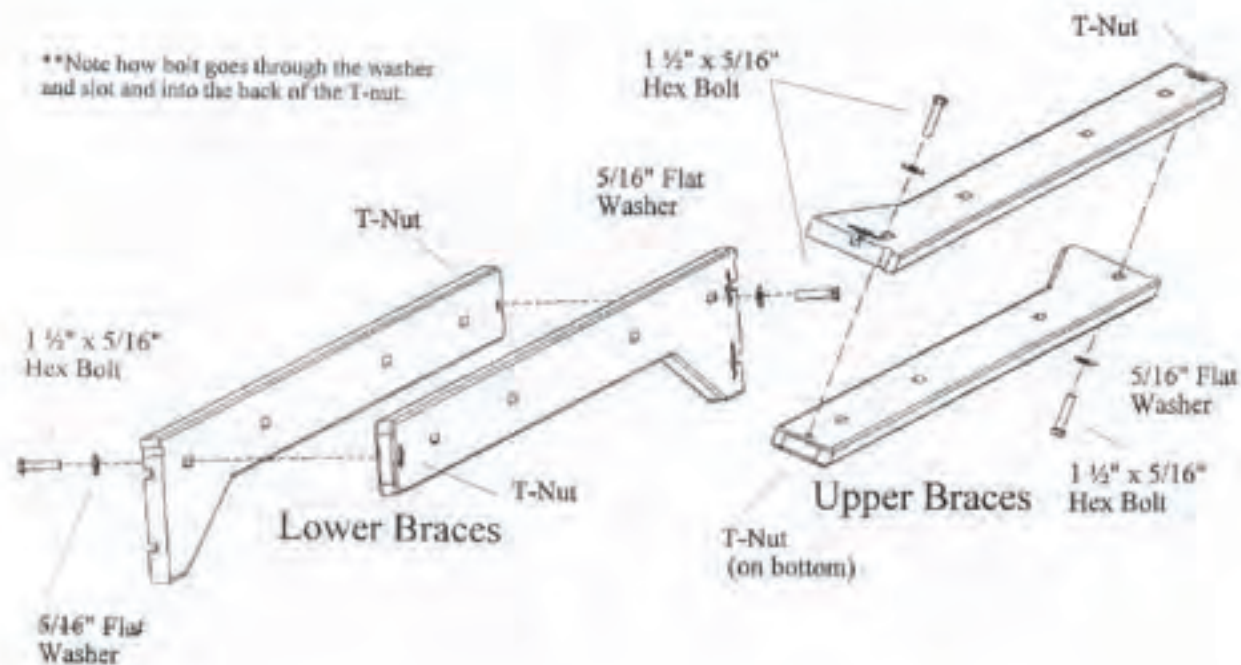

Step 8: Brace to Stand Assembly

Parts Needed: 1 - Right and Left pre-assembled sides
1 - Upper Brace assembly (untightened)
1 - Lower Brace assembly (untightened)
6 - 60 mm Connector Bolts (Longer)
6 - Rectangle Nuts
1 - Allen Wrench (provided)

- Before you begin, the right and left preassembled sides will have to be positioned as pictured below (feet down, pivot section upright, and pole mount positioned in a high tilt setting (at least four slots high-enough to expose the slot hole in the Pole Mount End).
- Begin with the Lower Brace. Align the keyed end of the brace into the slots located on the inside of the Diagonal Stand.
- Place a connector bolt through the hole of the Diagonal Stand (from the outside) and into the keyed end of the brace.
- Place a rectangle nut in the brace slot so that its threaded hole lines up with the bolt. Thread the bolt through the rectangle nut and completely tighten using the allen wrench.
- Continue this procedure until all four bolts are holding the Lower Brace assembly in place.
- Now position the Upper Brace assembly into the slots of the Pole Mount End as pictured.
- Repeat the steps above using the 60 mm bolts and rectangle nuts, completely tightening all bolts with the allen wrench. **CONTINUE TO LEAVE THE HEX BOLTS THAT CONNECT THE BRACES TO EACH OTHER LOOSE AT THIS POINT.**

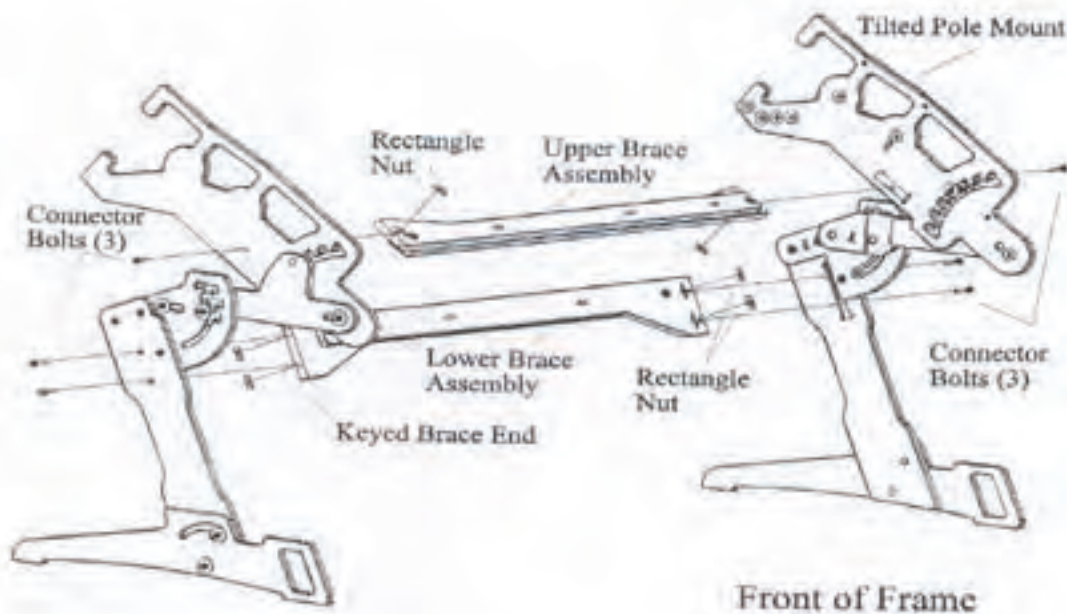

Step 9: Quilting Pole Assembly

Parts Needed: 4 each - PL55-5NM F, PL19-5NM E, PL48-5NM D

Connector Bolts 35 mm (Shorter)

8 - Plastic Washers

4 - Pole Caps

4 - Quick Release Springs

8 - Guide Dowels

4 - Quick Release Hooks

8 - Grabber Screws

"F" and "E" Pole Assembly

- First, you will assemble the "F" (55 1/2") and "E" (19 1/2") poles. Gather these poles together along with the grabber screws and Guide Dowels.
- Insert a Guide Dowel into the ends of each "F", "G", "E" poles WITH THE SMALLER HOLE OF THE GUIDE DOWEL INWARD.



- Insert a grabber screw into a Guide Dowel. Using a Phillips Screwdriver, screw the grabber completely into the rail.

"D" Pole Assembly

- First attach the Quick Release Springs to the ends of the Quick Release Hooks. This is done by slipping the springs over the knob as pictured.

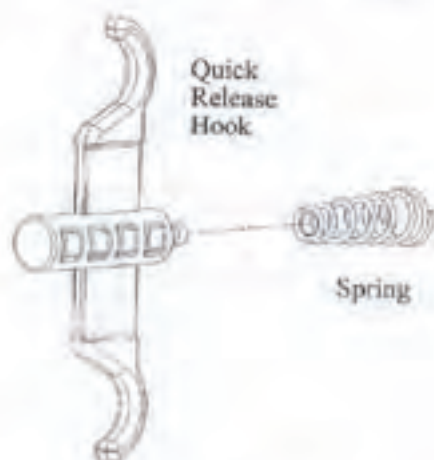

- Place the Quick Release Hook assembly into the slots that are cut into the end of each "D" Pole.
- Next place a plastic Pole Cap onto the end of each "D" Pole. The slotted side of the Pole Cap goes in the inside (toward the pole).

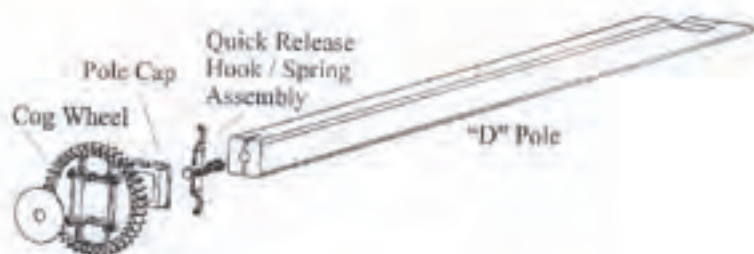

Connecting Pole to Pole

- Look at the rails needed to make the size you have selected. Align the slanted ends of the pole parts together and insert a 35mm connector bolt into the each outside hole. Continue inserting the bolt through to the metal T-nut insert.
- Begin all the bolts by hand, then tightly holding the wood pole together align it squarely on all sides. Line up this joint completely and then use the socket to tighten all bolts. Continue bolting together all slanted ends of poles until you have four Quilting Poles



POLE ASSEMBLY (BY LENGTH OF QUILTING SPACE)

Quilt must be at least 1' smaller than the overall length of pole.

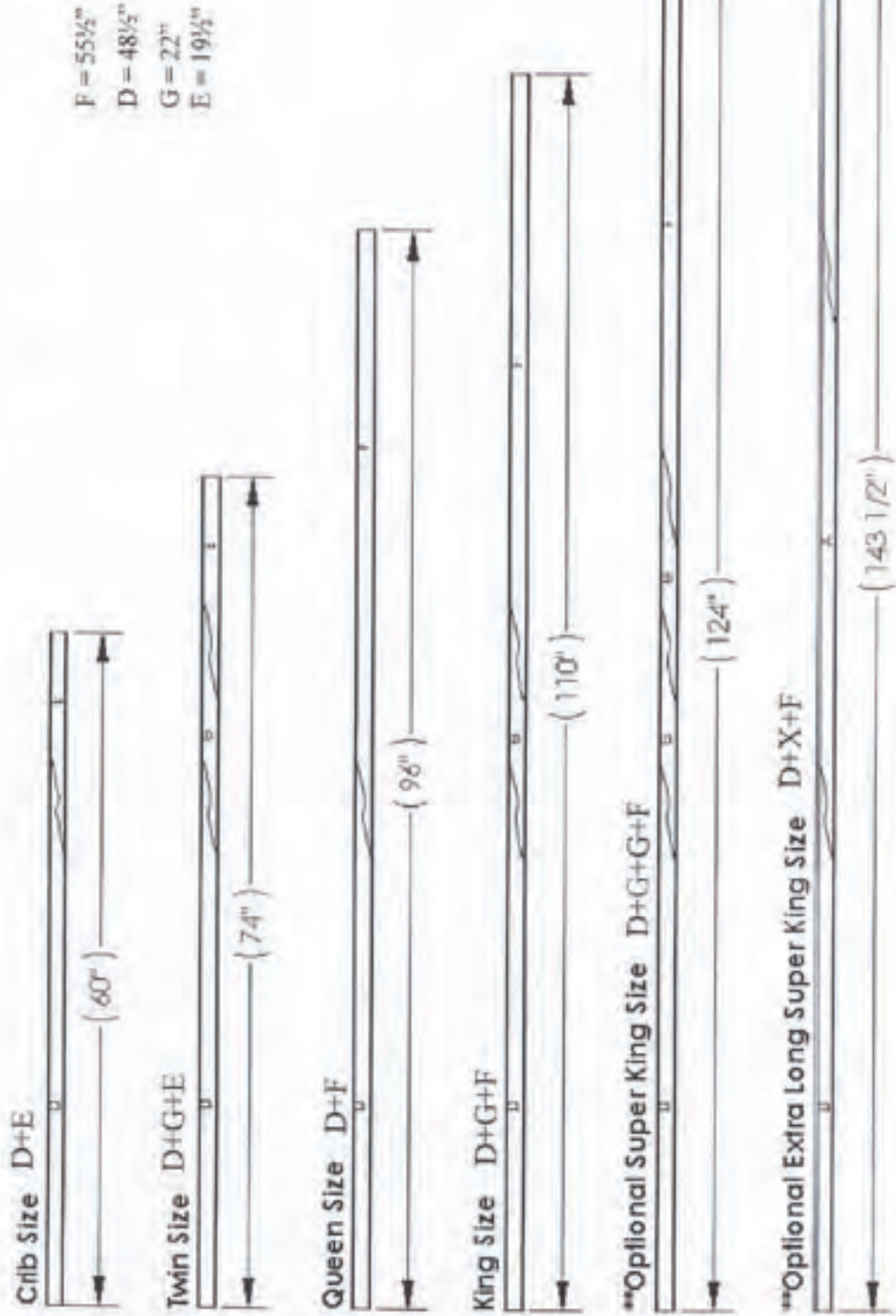

Step 10: Quilting Pole to End Assembly

Parts Needed: 4 - Assembled Poles

8 - Plastic Washers

3 - Cog Wheels

3 - Cog Stops

3 - 35 mm Connector Bolts (shorter)

- TIP: Observe the direction of the Cog Wheels teeth as illustrated and follow while assembling the quilting poles to the Ends.
 - *****IMPORTANT: Before completing the next step, keep in mind that the connector bolt should be about 1/4" too long. THE BOLT SHOULD NOT BE TIGHTENED WITH ANY TOOL. TO AVOID DAMAGE, TIGHTEN THIS BOLT WITH YOUR FINGERS ONLY.**
 - Install the three cog stops as illustrated using the shorter connector bolts into the metal inserts of the Right Pole Mount End.
 - Slip a Cog Wheel onto the end of one "D" Pole. Slip a plastic washer onto each end of the pole assembly. Position the end of the pole that **does not have the Cog Wheel on it** into the **LEFT FRONT HOLE** in the Left Pole Mounting End (just inside the lamp holder). (NOTE: There are three hole options giving you slight height adjustment. Be sure to place each end in the same level hole).
 - As you position the Cog Wheel end of the pole into the Right Pole Mounting End, pull the Quick Release Hook back, then release it into the hole. Test the cog stop to make sure it fits snug into the teeth of the wheel. If it does not, slip the wheel off and flip it around so the teeth go the other direction.
- *TIP-With the first pole in place, it may be necessary to adjust the width of the frame with the slots in the braces so that the pole will roll freely but will not will not move more than 1/16" from side to side.*
- Complete the above steps for the two other poles with Cog Wheels. Remember, the wheel rotation will be opposite from the wheel on the front pole.
 - Finally, put the lower pole ("4th Pole") in place, left side first. The right side goes into round disc already in place on the frame. (This pole does not have a cog wheel. This is to avoid the possibility of batting tear-out of a cog wheel was not released by mistake.

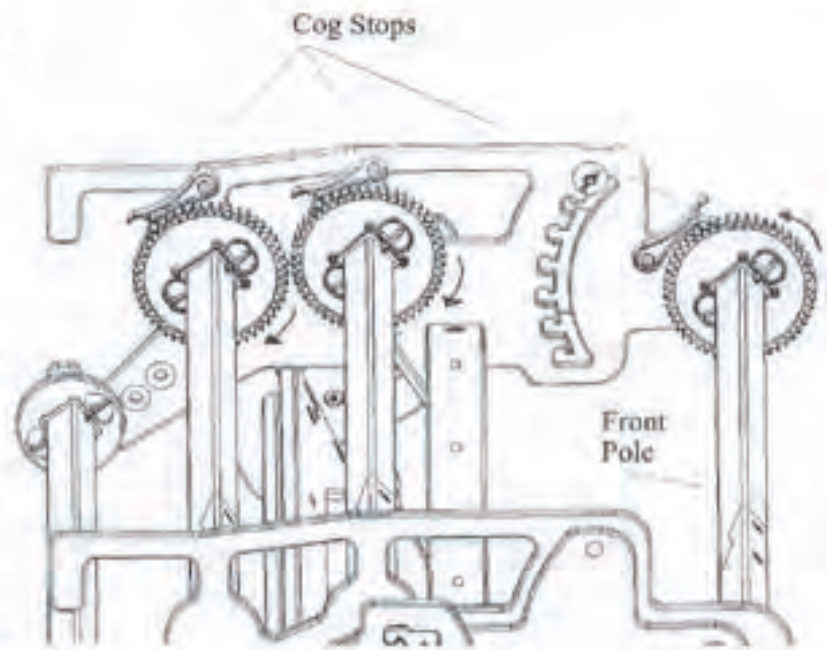

Step 11: Final Frame Adjustments

- After all the poles are in place, adjust the Upper Brace so that all the poles will roll freely but will not move from side to side.
- Tighten the 5/16" hex-head bolts that are in the slots on the Upper Brace.
- Adjust the Lower Brace so that the tilt action will move smoothly and easily.
- Tighten the 5/16" hex-head bolts that are in the slots on the Lower Brace.
- Double-check the Brace to Stand Assembly, making sure all connections are completely tightened.

Tilting The Z44™ Professional

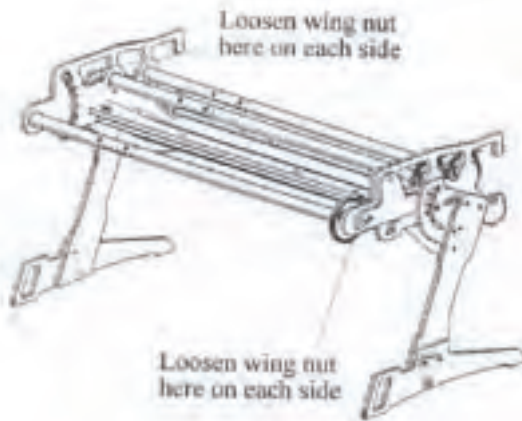

STEP 1: To change the tilt angle of the frame, there are four wing nuts to loosen: the wing nuts on the outside of the pivot section (one on each side), and the wing nuts on the inside of the pole mount end (one on each side).

STEP 2: Standing at the back of the frame, grip the pole assembly by the back or middle rail and pull back. This will free the bolts from the ratchet slot. Raise or lower the assembly to a different angle.

(NOTE: For best results, change the angle one side at a time).

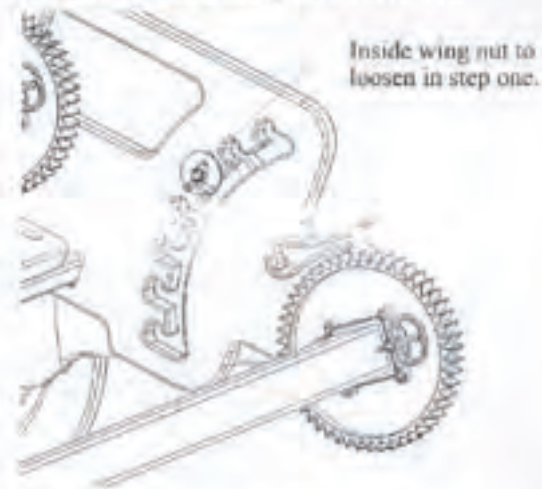

STEP 3: Slide Pole Assembly forward again until the bolts on both ends rest completely seated between teeth in tilt arch.

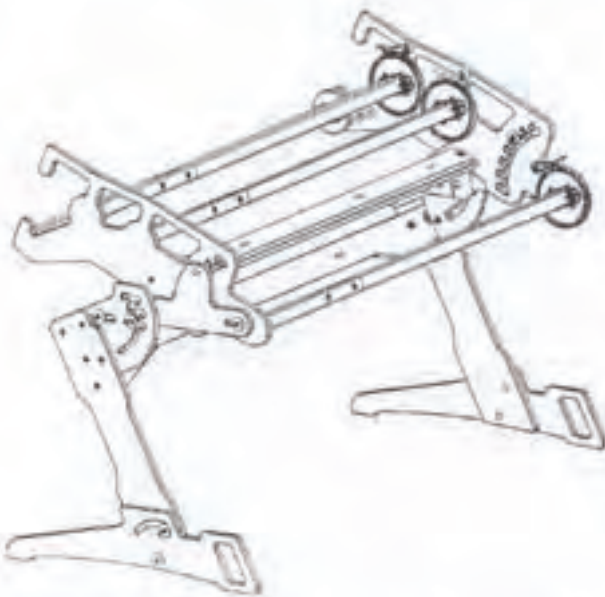

STEP 4: Re-tighten the wing nuts on the Pivot Sections and Pole Mount Ends.

ADJUSTING THE Z44™ PROFESSIONAL FOR HEIGHT:

STEP 1: For best results, make sure all wing nuts are tightened, except for the wing nuts on the outside of the Tilt Head (two on each side).

STEP 2: Standing at the front of the frame, pull out the Pole Assembly until the front bolt enters the slot. Adjust to the desired height and push the bolt into the appropriate ratchet slot. Do this one side at a time, being sure to adjust both sides to the same setting.

STEP 3: Retighten the wing nuts on the Tilt Head.



***NOTE: IF THE FRAME PARTS DO NOT MOVE AT THE JOINTS SMOOTHLY, CHECK THE NYLON LOCK NUTS AND MAKE SURE THEY ARE NOT OVERTIGHTENED.

Folding and Storing your Z44™ Professional

Your Z44™ has a tool-free folding process that takes only a couple of minutes. Keep the following things in mind:

- **Frame must not be tilted when it is to be folded.** (See "Tilting the Z44™ Professional" in previous section.)
- Set the tilt to the horizontal setting (top notch). Re-tighten the tilt-control wing nuts on the Pivot Section (one on each side).
- The folding feature will not affect the quilt in progress.
- The depth of the folded frame is about 16".
- **Follow the steps in order, without variation.**
- **Reverse steps to unfold.**
- You can use the WingGrip™ Tool to loosen and tighten your wing nuts!



STEP 1: Loosen the wing nuts on the outside Tilt Heads (one on each side).

STEP 2: Lift the pole assembly up, and allow it to slide down

STEP 3: The pole assembly will drop down until it rest diagonal against the stand (see below).

STEP 4: Re-tighten the two wing nuts loosened on the Tilt Heads.

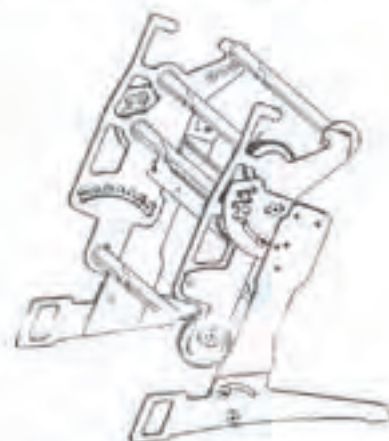

STEP 5: Loosen the wing nuts on the Base Legs (one on each side)

STEP 6: Lift the frame by the brace until the Base Legs drop in the slot.

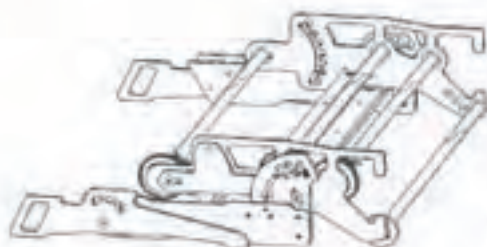

STEP 7: Gently lay frame down and re-tighten wing nuts. (If the Base Legs do not drop down and fold automatically, or if your frame is set up in a bigger size, it will be easier to fold the Base Legs manually, one side at-a-time.

STEP 8: Lifting the frame by the braces, stand the frame on its head as pictured (right) so it can be free-standing.

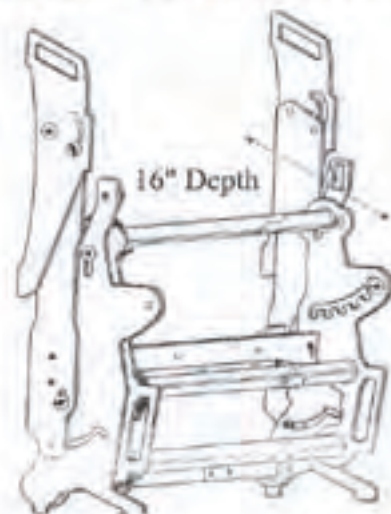

***NOTE: IF THE FRAME PARTS DO NOT MOVE AT THE JOINTS SMOOTHLY, CHECK THE NYLON LOCK NUTS AND MAKE SURE THEY ARE NOT OVER-TIGHTENED.

Assembly of EdgeMaster™ Set

Application and Use of EdgeMaster™

- The Edgemaster™ keeps the side tension of the quilting fabric even. Slide the hooks around the back side of the front and middle poles. The bar with the cloth sleeve should rest on top of the two poles, with the sleeve facing toward the work area.
- There are four tightness settings available. The best one will depend on the angle of your poles as they rotate around. (Example: If you are clamping down on the corner of the front pole, you will need to clamp down in a less tight setting).



- To test the appropriate tightness setting, lift the handle up to the unlocked position and move it to a different notch and gently pull down to the locking position. **If it strongly resists locking down, DO NOT FORCE.** The setting may be too tight. (typically the cloth sleeve bar will bend under the pressure of a setting that is too tight).

- Pin the quilt edge to the muslin strip. Next, as you lock in the appropriate tightness setting, pull gently away from the work area to achieve desired side tension. **Do not distort fabric by pulling it too tautly.**

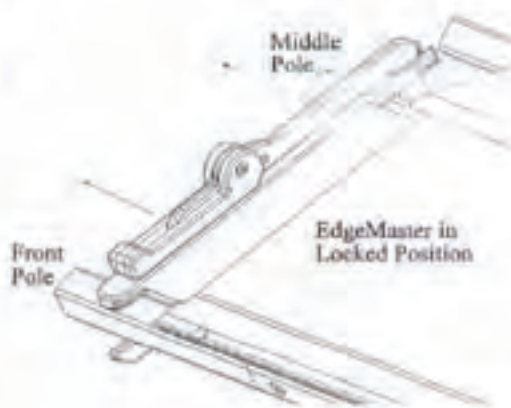

Assembly of Accessories

(Available through the Grace Company: 1-800-264-0644)

SuperKing™ Extension Assembly

- The parts and assembly configuration pictures for the SuperKing™ Extension Pole are located on page 9. The Brace parts and assembly configuration pictures for the SuperKing™ Extension set-up are located on page 5. Follow those pictures and directions as you set up the frame into the SuperKing™ length.

Extra-Long SuperKing™ Extension Assembly

- The parts and assembly configuration pictures for the set-up of the Extra-Long Pole are also included on the pole and brace pages. Follow the directions for setting up the frame into the Extra-Long Pole length on both the Brace and pole instructions and pictures.

HOW TO USE YOUR *GraceFrame*TM

Your quilt fabrics may be tacked directly to the poles. However, using cloth leaders is a much better way to attach your quilt (see the cloth leader instruction sheet). Leaders are easy to make and allow the quilter to move the last few inches of the quilt forward from the rear pole to the front quilting area. If you choose to use leaders, refer to those instructions for making them and put them on the frame before applying the quilt fabric to the poles.

1. BACKING FABRIC

The first fabric that will be applied to the quilting frame is the **Backing**.

The **Backing** is also known as the lining fabric. This piece of fabric will be the under side of the finished quilt. It is recommended that this piece of fabric be 2" to 4" larger than the top on all four sides, especially if your top is a pieced top.

(A pieced top may possibly stretch out and become larger than the backing if you do not make this allowance).

The **Backing fabric** can be one continuous piece of fabric or can be made by sewing fabric together.

Piecing the Backing fabric:

Cut the selvages before you piece the back fabric together. The selvedge is woven more tightly than the rest of the fabric and won't have the same "give" as the rest of the fabric which can cause the seam to be too tight. Use a slightly larger machine stitch than used in normal sewing when piecing the lengths of the back fabric together. Many quilts have **Back fabrics** that are not one continuous piece of fabric and are pieced together using two fabric pieces with a seam down the middle or three fabric pieces with two seams having been sewn. You can also sew your back fabrics together using crosswise piecing.

Front Pole-Backing fabric

1. Mark the center of **Backing fabric** with a pin or a pencil mark.

2. Tack the center mark to the center of the front pole. (The **Backing fabric** is put on with the wrong side of the fabric up and visible.)

3. Lay the fabric naturally and evenly along the straight edge of the pole. **Do not stretch the fabric.** Tack the corners of the fabric to the pole.

4. Add a few more tacks to hold

the material on the pole.

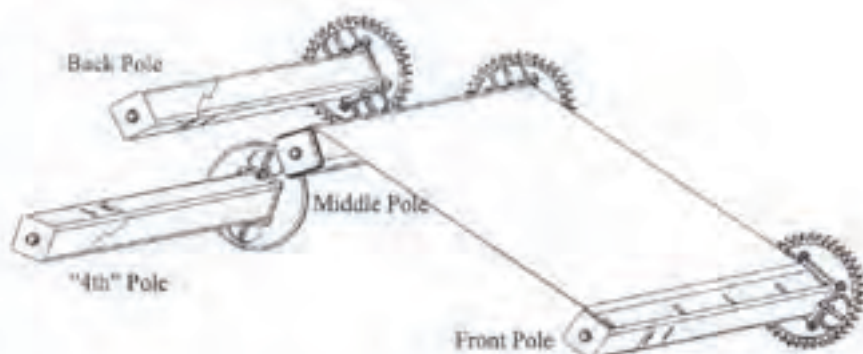

Middle Pole-Backing fabric

1. Tack the other end of the **Backing fabric** to the middle quilting pole, centering with the mark as directed on the front pole.

2. Tack the center mark to the center of the middle pole.

3. Lay the fabric naturally and evenly along the straight edge of the middle pole. **Do not stretch the fabric.** Tack the corners of the fabric to the pole.

4. Measure the amount of wood showing at the edges of the fabric to the end boards. This measurement should equal the amount showing on the front pole.

5. Securely tack the **Backing fabric** along the entire edge of the middle pole, using plenty of tacks.

Rolling the *Backing fabric* onto the middle pole

1. Roll the material onto the middle pole, making a smooth roll. Be sure there are no wrinkles present.
2. Smooth the quilt from the center to the outside edges of the pole as it is being rolled. **At this point do not roll the fabric tightly, just roll it nicely smooth and even.**
3. Roll until there is very little slack between the two poles.

Now, from the front of the frame, look at the fabric and readjust the fabric on the front pole if necessary. Sometimes, due to an uneven grain line of the fabric, the fabric will be loose in one area and tighter in another. First, try rolling the fabric completely from the middle pole to the front pole and then back to the middle pole again. Then if this did not adjust the fabric, simply even the tension by adjusting the tacks on the front pole. After adjusting the tension add additional tacks to hold the fabric on the front pole.

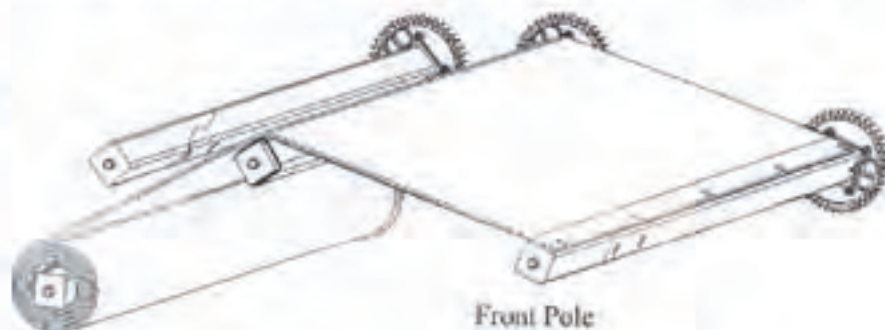

2. **BATTING** INSTALLATION

1. Center the **batting** on the front pole over the **backing** and tack down with a few tacks. Smooth **batting** over the back to the middle pole and let the **batting** drape to the floor between the **middle pole** and the **4th pole**.
2. At this point, leave the batting draped to the floor. You will roll it onto the fourth pole after applying the quilt top (pictures above show how it should look once tacked on).

3. **QUILT TOP**

1. Tack the center of the quilt top into the center of the front pole.
2. Smooth out the quilt top from the center to each corner. **DO NOT STRETCH.**
3. Tack the quilt top along the straight edge of the pole over the backing and the batting layers.
4. Drape the quilt top over the middle pole and let it hang between the middle and rear poles.
5. Tack the center of the quilt top edge to the rear pole.
6. Smoothly and evenly, **without stretching**, tack the fabric to the rear pole moving from the center to each corner.
7. Measure the quilt top edge to the end boards. This measurement should be the same distances as on the front pole.
8. Roll the quilt top onto the rear pole. Keep this roll smooth and loose, without allowing any wrinkles or creases to occur.
9. Now adjust the tensions of quilt top and backing fabrics until you get the desired tension. Adjust the tightness of the fabrics by turning the Cog Wheels by hand. **DO NOT OVER TIGHTEN.** Apply the wood stop to the Cog Wheels.
10. Now, tack and roll the batting onto the fourth pole as pictured.
11. Begin quilting from the front edge and roll as you go!

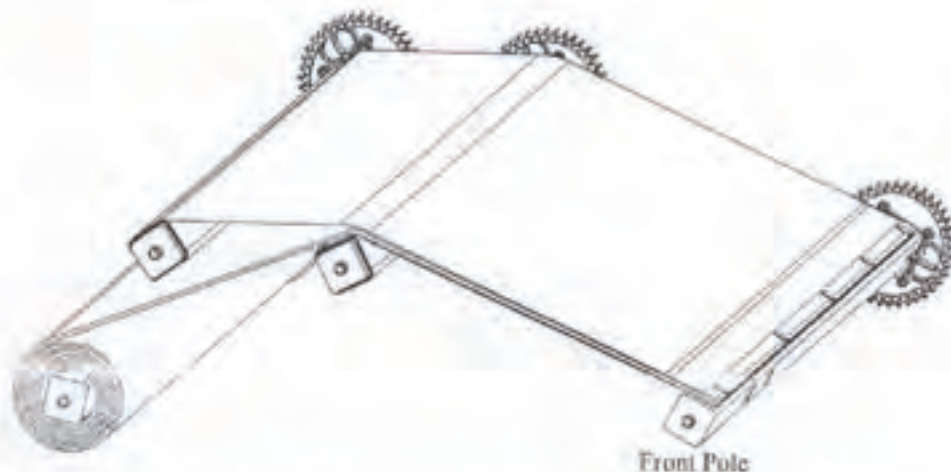

Happy Quilting!!

Use of *Optional* Cloth Leaders

This is a suggestion for making one kind of cloth leaders. There are many ways and ideas for making these leaders. Don't be worried about trying your own idea. Just remember that the longest strip of fabric should be applied to the rear pole. This allows the whole quilt to come up into the area of quilting without stopping and adjusting the quilt top to the second pole in order to finish it.

The best cloth selection for making cloth leaders is unbleached muslin.

Purchase: 1 1/2 yards for 58" pole (crib)
 2 yards 72" pole (twin)
 2 2/3 yards for 94" pole (queen)
 3 yards for 108" pole (king)

- To reduce the amount of tacking and un-tacking of cloth leaders as you change frame sizes is to make a cloth leader for each individual pole piece. Have it run from the straight end of the pole to about half-way through the slant (or cut) end. -OR- After you know the frame size you want, make a cloth leader for that size as shown below and add about 7" to its length. This will give you the extra material you need to make a header that the pole can slide into. This will eliminate the need for tacking the leader or having separate leader pieces.
- **Step 1.** Cut the fabric as shown in illustration above.
- **Step 2.** Finish the cut edges of the leaders with either a serge stitch or with a very straight 1/2" hem allowance. **Press the leader cloth with a warm iron.**
- **Step 3.** Draw straight, dark, solid line 1" from one edge of each of the leader cloths.
- **Step 4.** Thumb tack the cloth leaders to the poles as shown on illustration below.
- **Step 5.** Pin or baste your quilt fabrics to the cloth leaders. Use the dark, straight line that you marked on your leaders in Step 2 to align your quilt fabrics with.
- **Step 6.** Roll the Cloth Leaders and Quilt Fabrics up on Poles.
- **Step 7.** You are now ready to begin quilting.

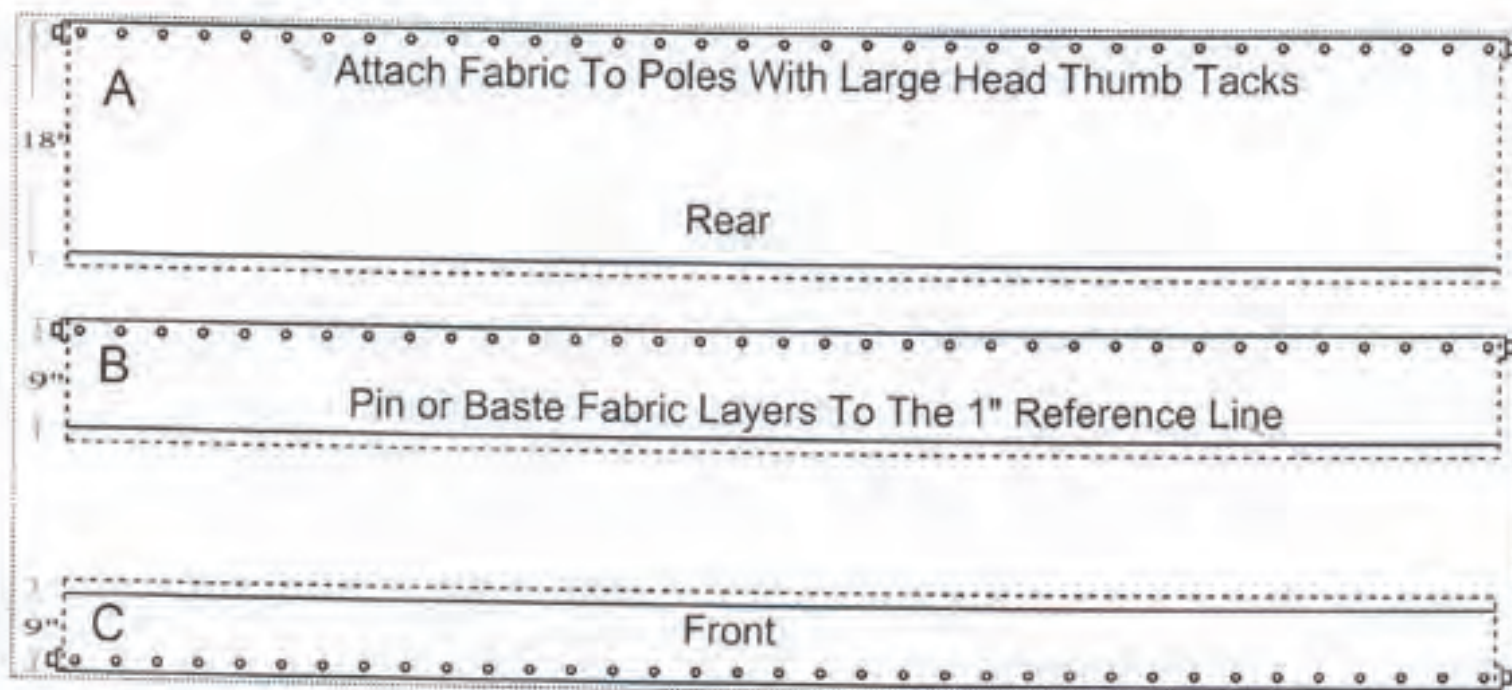

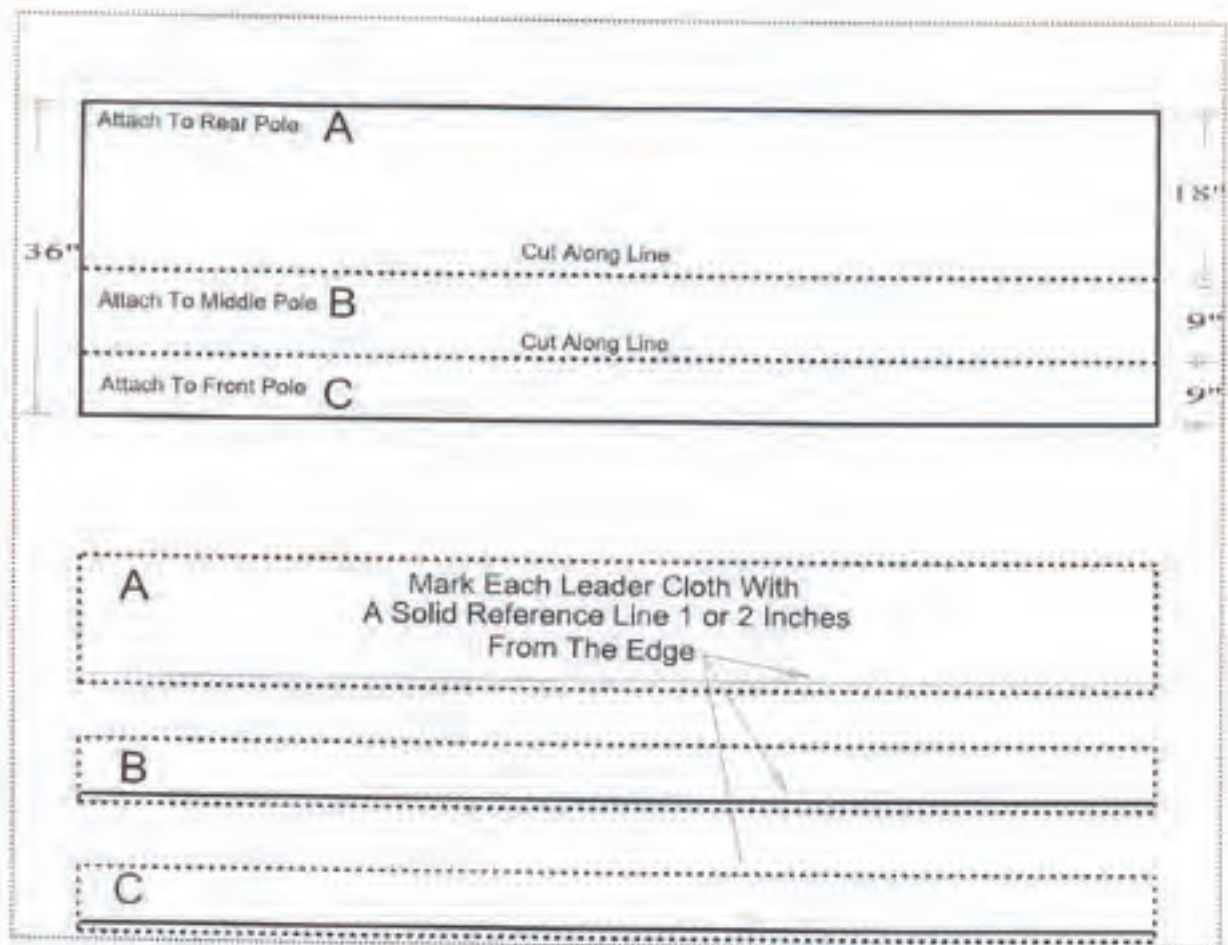

Trouble Shooting

Problem: Fabric sags on one side or in middle.

Solution: Fabric may not be cut evenly straight or the grain of the cloth may not be square. Take it off and square it up or pull (gently) to square.

Problem: Sides of quilt have a concave edge.

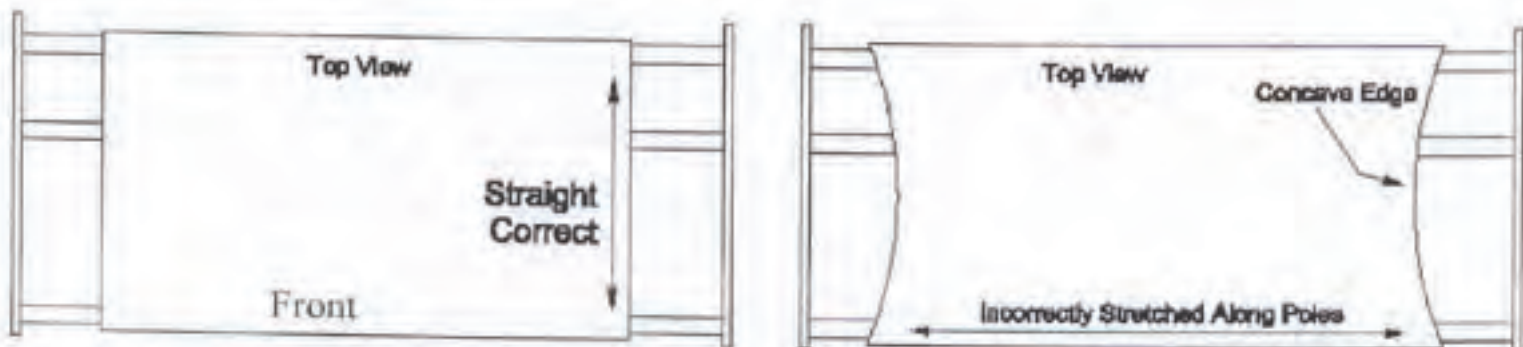

Solution: The fabric was stretched along the pole. Take the fabric off and let it relax until it is not misshapen and then re-install, without stretching it along this edge.

Problem: Quilt backing is much longer than quilt top, after quilting.

Solution: Monitor tension of backing and quilt top. Mark on edges of fabrics every six inches on backing and

quilt top and as you roll you will be able to monitor the tension.

Problem: Batting tears or separates during the tightening of the cogwheels.

Solution: The batting was stretched and stressed. The batting should be longer than the quilt that you are making and there should not be tension applied to it. Check the 4th pole to make sure that it is rolling smoothly and easily.

Problem: Poles are bowing in.

Solution: The causes may be: 1. Seam down the center of the fabrics may be sewn too tight and is not giving with the rest of the fabric. If the seam is the problem the quilt may be attached sideways. 2. Fabric is not cut evenly. 3. Too much tension has been applied. 4. Fabric has been stretched along the poles instead of smoothly laid along the pole then attached.

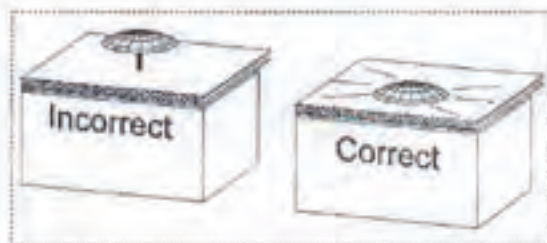

Problem: Fabric pulls/tears out at the thumbtacks when tension is applied.

Solution: Seat the tack all the way in. The head of the tack, not the post of the tack, should hold the fabric. Use a tack hammer to seat the tacks if your hand is not strong enough.

Problem: Poles squeak as they roll or they do not roll freely.

Solution: **The frame is not square!** Square it up with the floor using a carpenter's square or an uncut piece of poster board or a picture frame. If the quilting frame still squeaks after making sure that the frame is in good square alignment, rub some paraffin or candle wax on the dowel ends of the poles.

Helps for Quilting, and Especially Tying:

Before installing the quilt onto the frame, mark both the quilt top and backing in similar increments along the two side edges. (The sides that are not tacked onto the poles). While rolling the quilt during the tying process watch the marks. This will help you to keep an equal tension on the top and backing fabrics so you won't over tighten one or the other of your fabrics.

When rolling into a new area of tying, allow your last row of ties to remain in the new area of tying. Also, tie your knots tight. **Do not over roll past you last row of ties.**

