

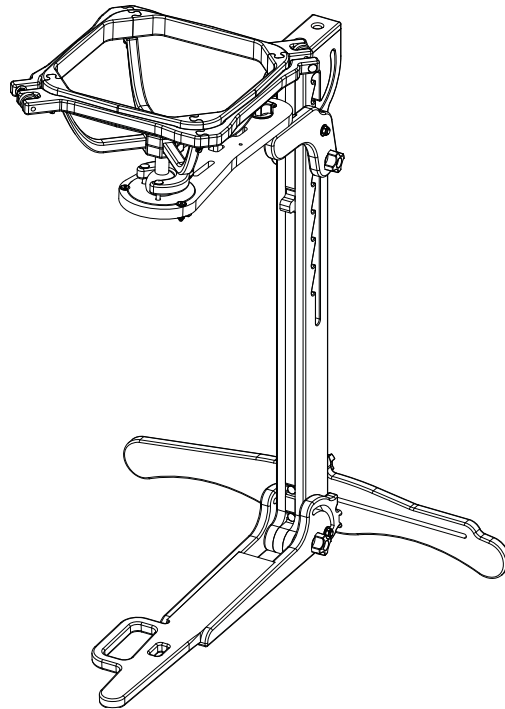

Quilting with The GraceHoop²TM 2005

Table of Contents

Customer Service Information	2
Care, Finishing and Storage	2
Warranty	2
Parts list (General Assembly and Hoop Assembly) ..	3-4
Stand Assembly	5-8
Hoop Assembly	9-10
Rotating and Adjusting the GraceHoop 2005 TM	11-12
Folding the GraceHoop 2005 TM	13
EdgeTool TM Assembly	14
Using the EdgeTool TM	14
Installing Fabric	14



Care of Your GraceHoop² 2005

The GraceHoop²™ 2005 is made from the highest quality Baltic Birch Plywood. The wood may be sealed and/or stained with an application of tung oil which will help preserve the wood and will help to prevent warping. Test stain on an inconspicuous place. Many different finishes and/or stains may be suitable for sealing and beautifying your hoop. You may want to consult your local paint retailer for finishes which will apply easily and dry hard – not oily.

TIP: Store the hoop in a dry place – preferably with the stand in vertical position.

5 Year Warranty Information:

GraceWood, Inc. will replace or repair, at our discretion, any part of the GraceHoop²™ 2005 with problems due to manufacturing or workmanship. This warranty does not cover parts damaged through misuse, improper storage, improper assembly, loss, natural events, and willful or accidental destruction. Parts must be returned to The Grace Company, shipping prepaid *using a company-issued RMA#*, before we can replace them. We will promptly return the repaired or replaced part at our expense. Customers will never have to pay the cost of a part covered by the 5 year warranty.

Address for Shipping of Materials to Grace Co:

2225 South 3200 West
Salt Lake City, UT 84119

For Regular Correspondence:

PO Box 27823
Salt Lake City, UT 84127

Technical Support:

1-800-264-0644

Office Hours:

8:00 am – 4:30 pm MST*

*Leave a message after hours; all calls will be returned.

Please report any errors or make constructive comments regarding these instructions to the PO Box listed above or by either of the following methods:

Fax (801)908-8888 ~ E-Mail: info@graceframe.com

The GraceHoop²™ 2005 is a new product with several original design innovations. Our products are superb in functionality and ease of use, due in part to the feedback we have received from the thousands of customers who use our products. If you have any suggestions that will help us improve our product or service, please write or call The Grace Company with your suggestions.

GraceHoop² 2005 General Assembly Parts List

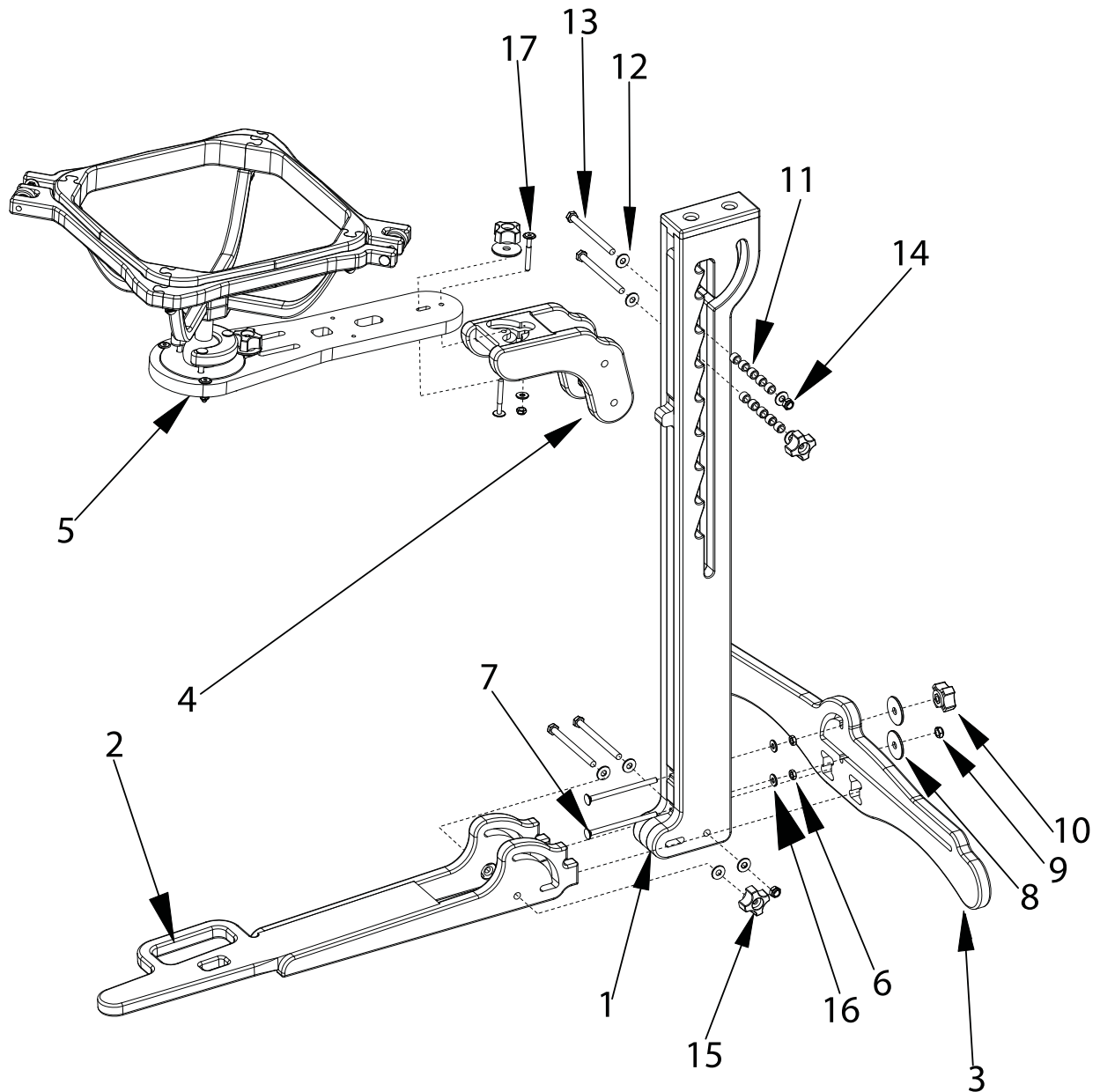

- 1: Vertical Stand (1)
- 2: Front Foot (1)
- 3: Back Foot (1)
- 4: Height Adjust Arm (1)
- 5: Hoop and Arm Assembly (1)
- 6: 1/4" Hex Jam Nut (4)
- 7: Carriage Bolt 1/4" x 4" (2)
- 8: Fender Washer 1-1/4" (2)
- 9: Thin Nyloc Nut 1/4" (2)

- 10: 1/4" Plastic Knob (2)
- 11: Roller Bushing (10)
- 12: Flat Washer 5/16" (8)
- 13: Hex Bolt 5/16" x 4" (4)
- 14: Thin Nyloc Nut 5/16" (2)
- 15: 5/16" Plastic Knob (2)
- 16: Flat Washer 1/4" (4)
- 17: Connector Bolt 1/4" x 50mm (2)

GraceHoop² 2005 Hoop Assembly Parts List

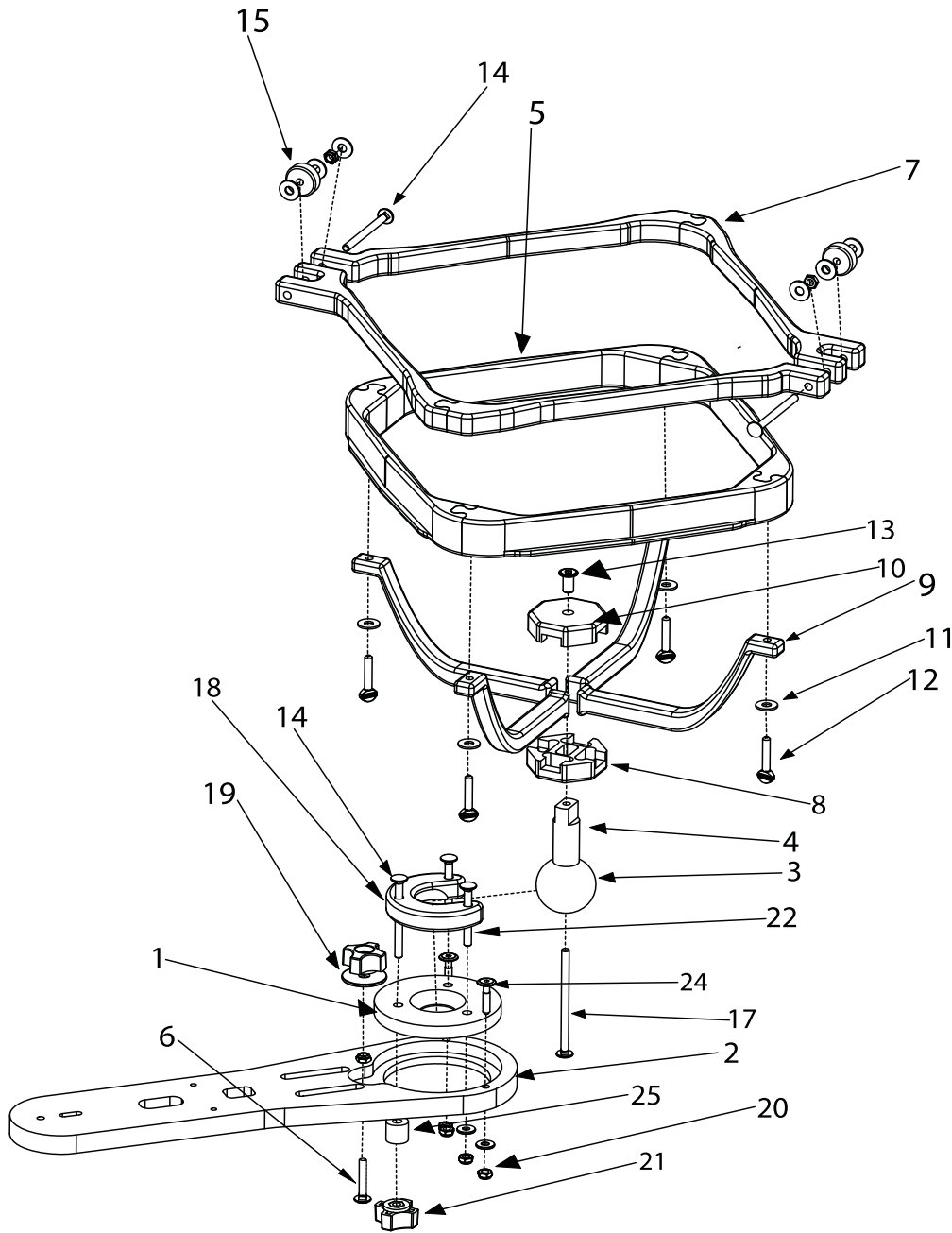

- | | |
|------------------------------------|-------------------------------------|
| 1: Ball Swivel Bottom (1) | 14: Carriage Bolt 1/4" x 3" (2) |
| 2: Arm (1) | 15: Knurled Finger Nut (2) |
| 3: 2" Ball (1) | 16: Hex Jam Nut 1/4" (8) |
| 4: Ball Swivel Dowel (1) | 17: Carriage Bolt 1/4" x 4" (1) |
| 5: Inner Hoop (1) | 18: Ball Swivel Top (1) |
| 6: Carriage Bolt 1/4" x 1-1/2" (1) | 19: Fender Washer 1-1/4" (3) |
| 7: Outer Hoop (1) | 20: Thin Nyloc Nut 1/4" (4) |
| 8: Bottom Bracket Clamp (1) | 21: 1/4" Plastic Knob (2) |
| 9: Bracket (4) | 22: Carriage Bolt 1/4" x 2-1/4" (3) |
| 10: Top Bracket Clamp (1) | 23: Connector Bolt 1/4" x 30mm (2) |
| 11: Flat Washer 3/16" (19) | 24: Connector Bolt 1/4" x 35mm (1) |
| 12: Thumb Screw 1/4" x 1-1/4" (4) | 25: Knob Spacer (1) |
| 13: Cap Nut 1/4" (1) | |

Assembly of the GraceHoop²™ 2005

Before You Begin:

- Using the parts list as a reference, make sure all parts of your assembly are present. If something is missing or broken, contact The Grace Company at 1-800-264-0644. We will promptly ship any needed item.

Hoop Stand - Out of Box, in folded position

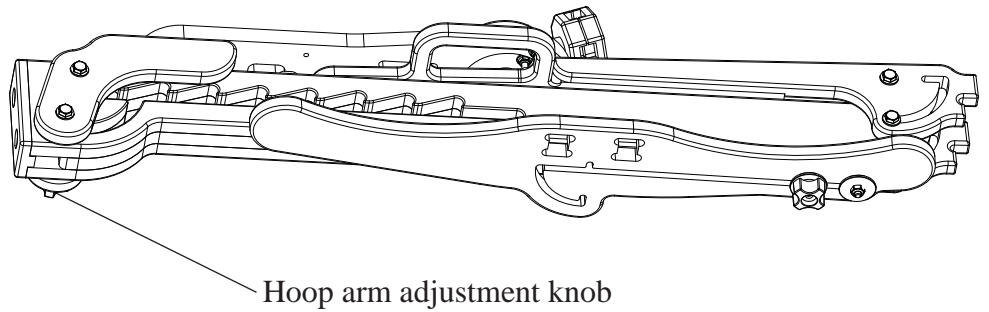

Tools Needed:

- Allen Wrench (provided)

Step 1: Remove the stand from the box.

- Remove the stand from the box. The stand is preassembled and shipped in a folded position. (Shown above)

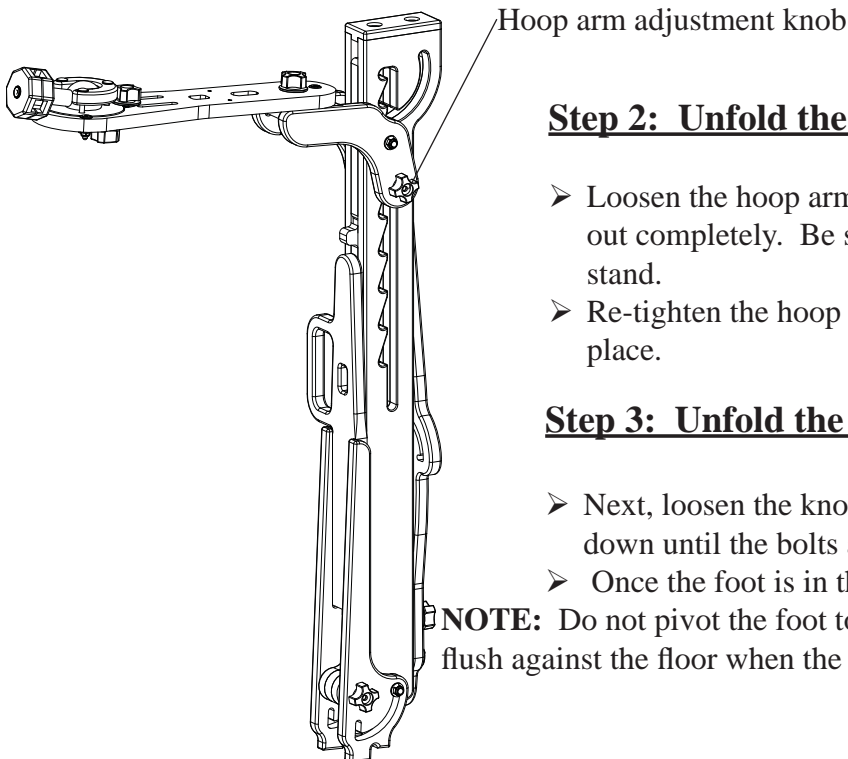

Step 2: Unfold the arm of the stand

- Loosen the hoop arm adjustment knob and raise the arm up and out completely. Be sure the bolts rest in one of the slots in the stand.
- Re-tighten the hoop arm adjustment knob to secure the arm into place.

Step 3: Unfold the back foot of the stand

- Next, loosen the knob on the back foot and slide the back foot down until the bolts are in the position shown below.
- Once the foot is in this position, pivot the foot clockwise.

NOTE: Do not pivot the foot too far! Both sides of the back foot should be flush against the floor when the hoop stand is upright.

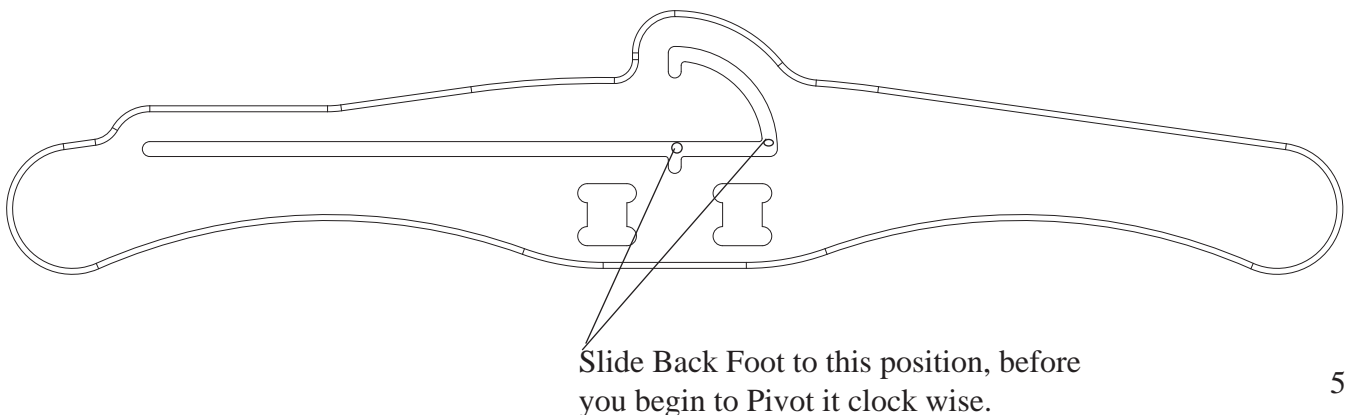

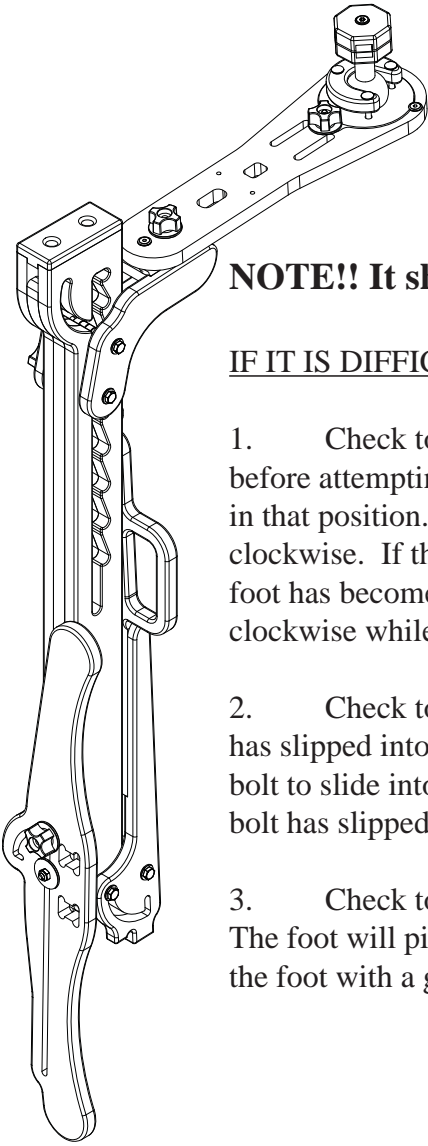

NOTE!! It should not be necessary to use force in order to pivot the foot.

IF IT IS DIFFICULT TO PIVOT THE FOOT:

1. Check to make sure that you have moved the foot into the correct pre-pivot position before attempting to pivot the foot (see picture at bottom of previous page). Hold the foot in that position. Do not allow the foot to move from that position as you pivot the foot clockwise. If the foot slips out of position during the pivoting motion, it may appear that the foot has become stuck. Pivot the foot in the reverse direction, then try again to pivot the foot clockwise while holding the foot in position at the same time.
2. Check to make sure that the bolt has not yet slipped into the grooved area. If the bolt has slipped into this grooved area, make sure you hold the foot so that it does not allow the bolt to slide into the grooved area and try to pivot the foot again. The foot will not pivot if the bolt has slipped into the grooved area prematurely.
3. Check to make sure that you are attempting to pivot the foot in the correct direction. The foot will pivot so that the knob will follow the track. Try to hold the foot even and pivot the foot with a gentle steady motion.

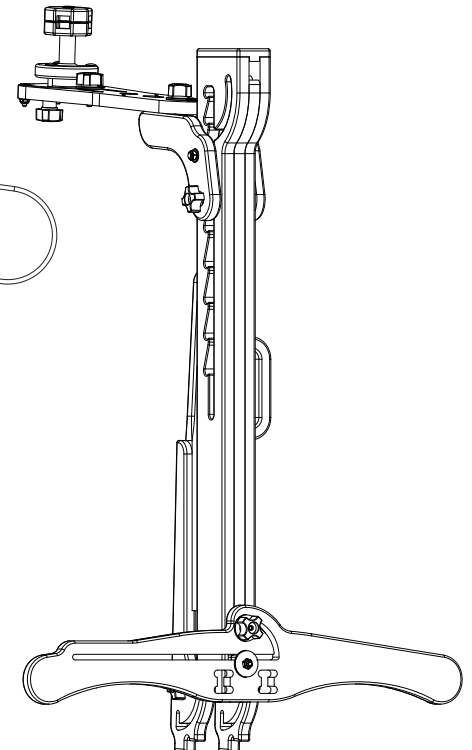
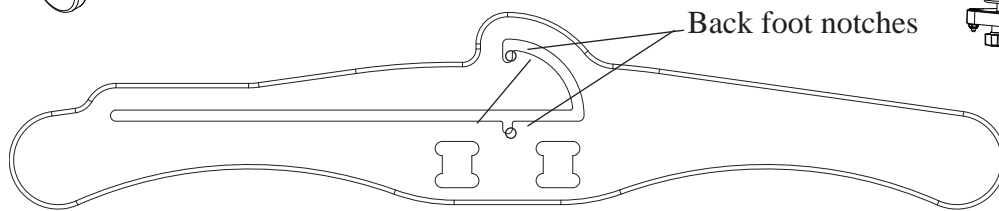

- With the back foot in the horizontal position, slide the leg up into the notches indicated in the picture above.
- Tighten the back foot adjustment knob to secure the foot into place.

Important!

Make sure that the back foot slides into the notches before you tighten the hoop stand back foot knob. If the back foot is not tightened in the correct position in the notches, the hoop stand *front* foot will not fit properly into place.

Step 4: Unfold the front foot of the stand

- Loosen the knob on the front foot of the stand and lower the front foot into the horizontal position.

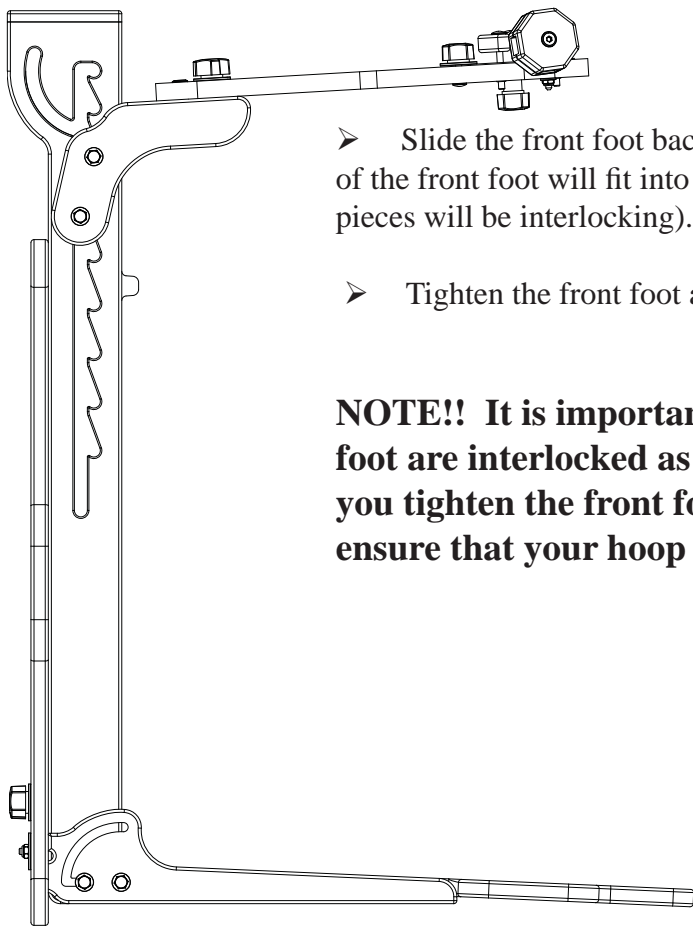
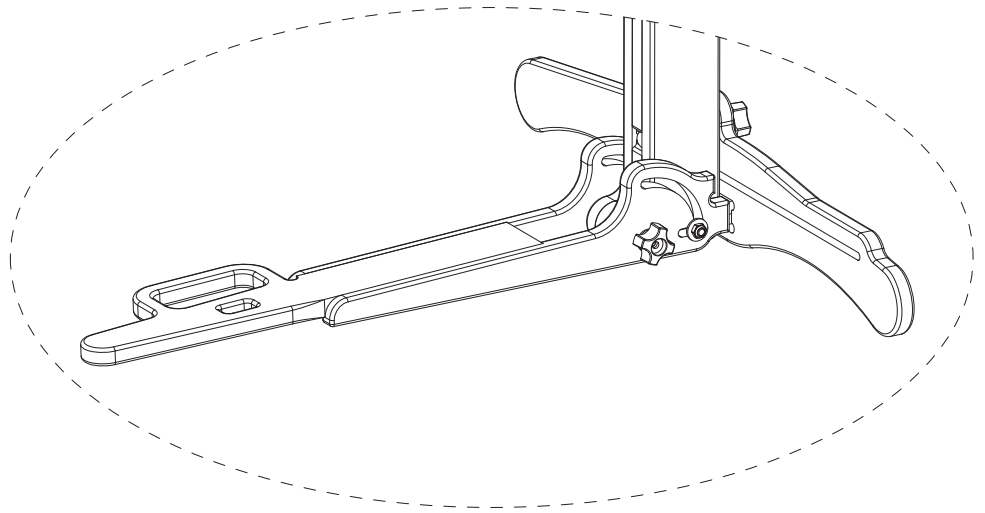

- Slide the front foot back into the back foot. (The tabs on the heel of the front foot will fit into the notches cut into the back foot so that the pieces will be interlocking).
- Tighten the front foot adjustment knob to lock the foot into place.

NOTE!! It is important that you ensure the back and front foot are interlocked as described in the steps above before you tighten the front foot adjustment knob. This will ensure that your hoop stand is stable.

Step 5: Position Ball Swivel

- Loosen ball swivel lock knob.
- Position ball swivel in vertical position as shown in the bottom picture.
- Re-tighten the ball swivel lock knob to secure the pivot ball into position.

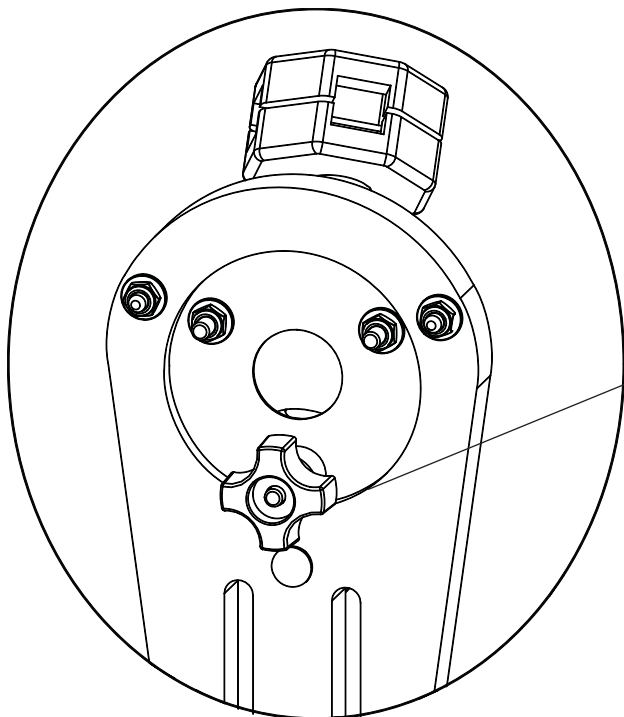

Ball Swivel Lock knob

Rotation Swivel Lock Knob

The pivot ball shown in vertical position

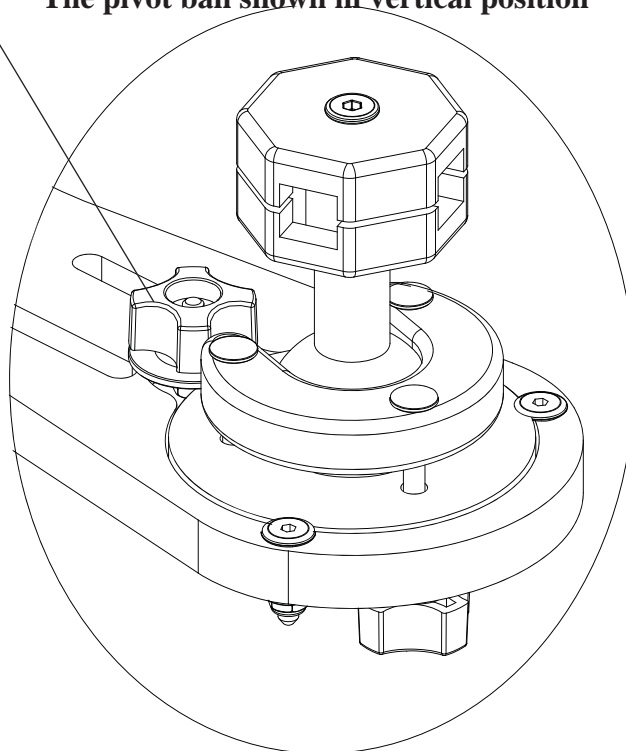

Step 6: Prepare the Stand for Hoop Placement

- Disassemble the ball swivel unit as described below.

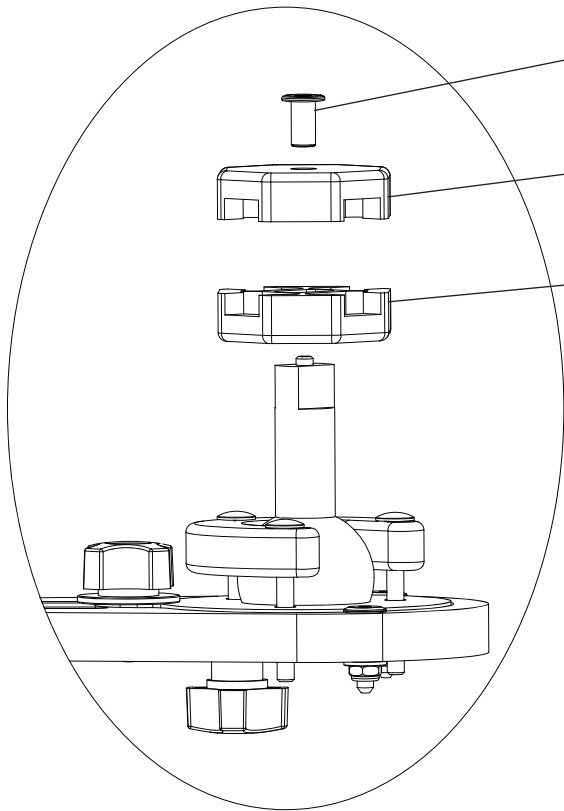

➤ Using the allen wrench (provided) remove the cap nut from the ball swivel unit.

➤ Remove the top bracket clamp from the ball swivel unit.

➤ Remove the bottom bracket clamp from the ball swivel unit.

- Set these parts aside momentarily.

Step 7: Assemble the hoop

- Screw the brackets to the inner hoop using the thumb screws and washers.
- Place the bottom bracket clamp onto the bottom of the brackets, hold in place.
- Place the top bracket clamp onto the top of the brackets, hold in place.
- Continue holding the bracket clamps in place on the brackets.

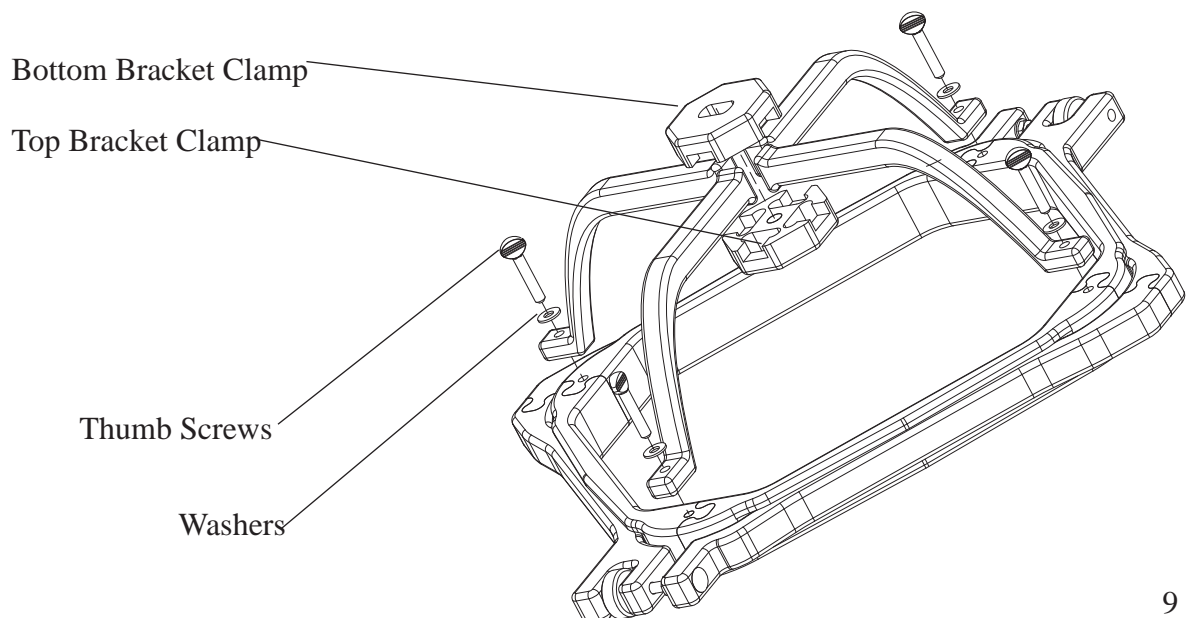

➤ Brackets and clamps attached to hoop.

➤ NOTE: You should still be holding the bracket clamps in to place.

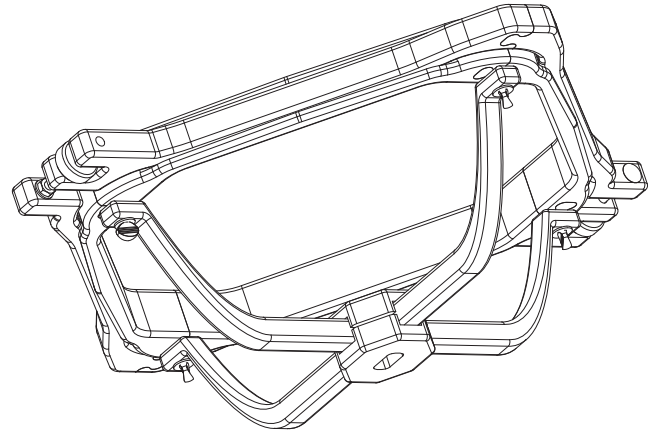

Step 8: Attach Hoop To Stand

- Attach the hoop to the ball swivel using the cap nut previously removed from the ball swivel unit in step #6.

NOTE: The cap nut goes through both the top and bottom bracket clamps and onto the bolt that comes out of the stem of the ball unit. (Tighten the cap nut using the allen wrench

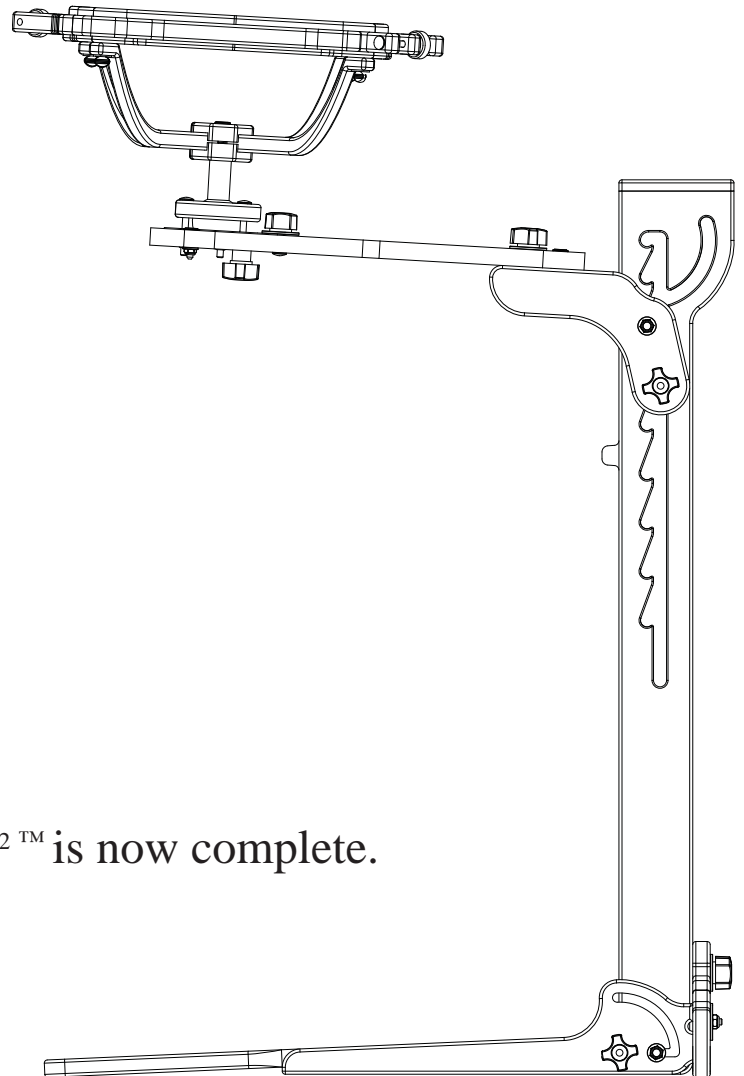
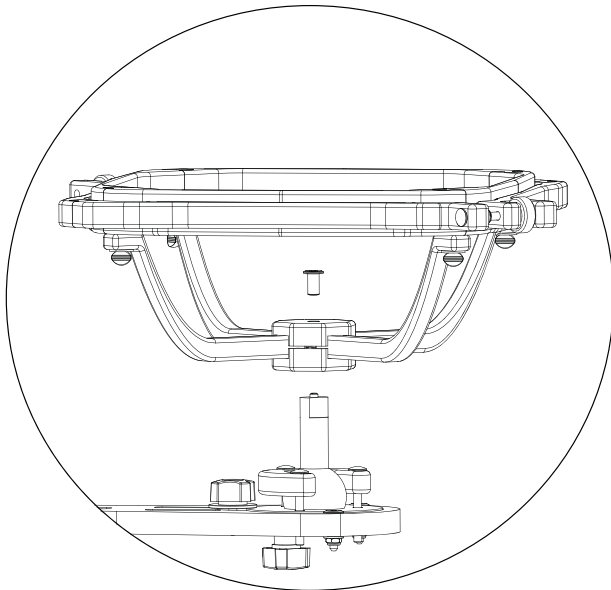

Congratulations!

Assembly of your GraceHoop²™ is now complete.

Rotating And Adjusting The GraceHoop²™ 2005

There are four main ways to adjust the GraceHoop²™ 2005 to customize your working area.

- With the hoop swivel adjustment knob.
- With the hoop rotation adjustment knob.
- With the arm pivot adjustment knob.
- With the arm height adjustment knob.

Each of the adjustment knobs listed above will allow you to adjust the GraceHoop²™ 2005 to the perfect position that is just right for you personally.

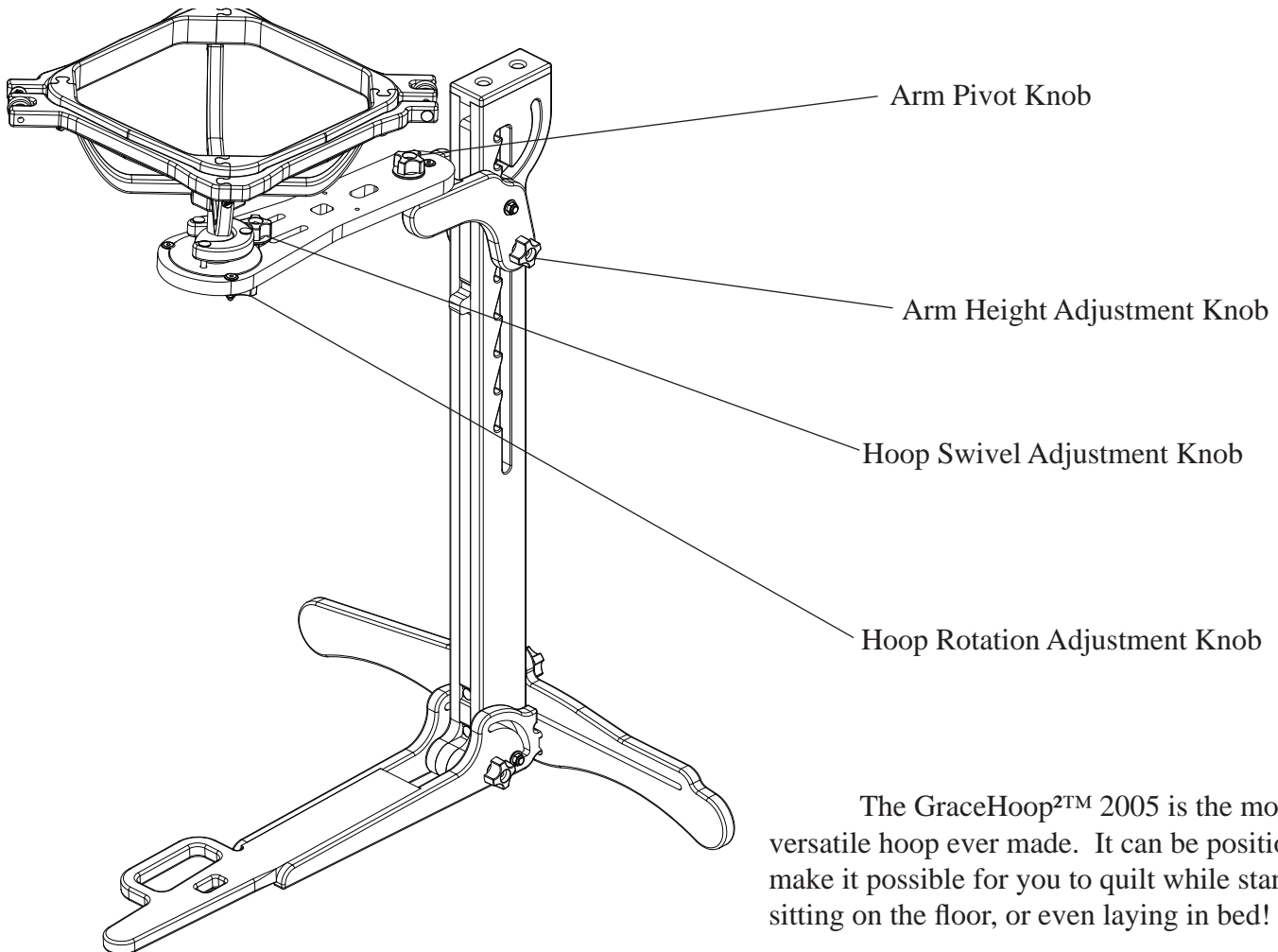

Before you begin quilting, we recommend that you install a quilt, sit at the stand, and experiment with the hoop and its rotational abilities. You may even experiment sitting at different sides of the hoop or in different chairs at different levels.

See next page for adjustment information in more detail.

➤ **The Hoop Swivel Adjustment Knob:**

The hoop swivel adjustment knob allows you to angle the hoop. You may tilt it to the exact angle of comfort. Just loosen the hoop swivel adjustment knob, swivel the hoop until you find the desired position, and then tighten the hoop swivel adjustment knob to secure the hoop at that angle.

➤ **The Hoop Rotation Adjustment Knob:**

The hoop rotation adjustment knob allows you to rotate the entire hoop while keeping the hoop locked securely in the exact angle you have selected by using the hoop swivel adjustment knob. This allows you more versatility than you could have ever expected from a quilting hoop before.

➤ **The Arm Pivot Adjustment Knob:**

The arm rotation knob allows you to rotate the **arm** of the hoop stand 180°. You can rotate the arm 90° to the left, or 90° to the right or stop anywhere in between, while keeping the hoop in the exact position you have set. This is particularly helpful in allowing you to get up from behind the hoop without a lot of hassle. The adjustment can be made by loosening the arm pivot adjustment knob, pulling the arm out away from the stand, then rotating the arm of the hoop in the desired direction. Righten the arm pivot adjustment knob to secure the hoop arm into place. When putting the arm back in its original 90-degree position, push the arm back toward the stand to lock it into place, then retighten the knob.

➤ **The Arm Height Adjustment Knob:**

The arm height adjustment knob allows you to adjust the height of the hoop on the stand while keeping the hoop swivel, hoop rotation and arm pivot adjustment settings locked into the desired position. The notched stand allows you to choose from eight different height settings. Just loosen the arm height adjustment knob and, while holding the hoop arm for support, guide the hoop arm either up or down to the desired height. Then allow the hoop arm to slide into the notch at that position before tightening the arm height adjustment knob once again to secure the arm into your personalized height setting. Be sure to tighten this adjustment knob well, to provide stability for the hoop.

Note: Do not loosen the front or back foot adjustment knobs while attempting to adjust the hoop for use. The adjustment knobs for the feet must be tightened during use for your safety and the stability of the stand.

Folding The GraceHoop² 2005 for Storage and Toting

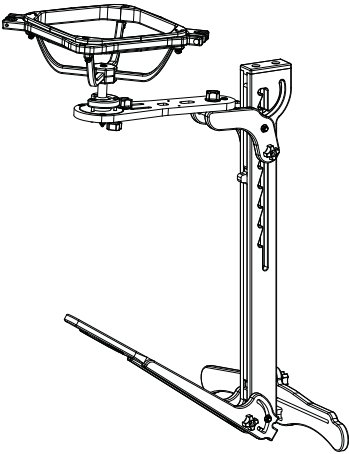

- Loosen the front foot adjustment knob.
- Pull the front foot out just a bit, so that it is no longer interlocked with the back foot.
- Fold the front foot up to the stand.
- Make sure that the foot folds up snugly against the stand leg to prevent movement in storage.

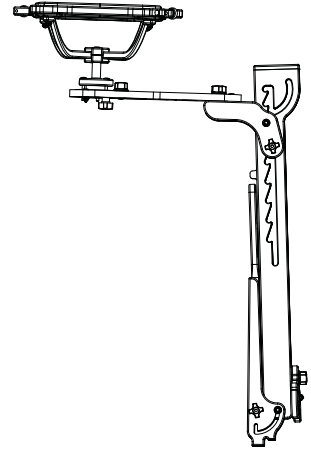

Bottom screw follows this groove to fold arm in.

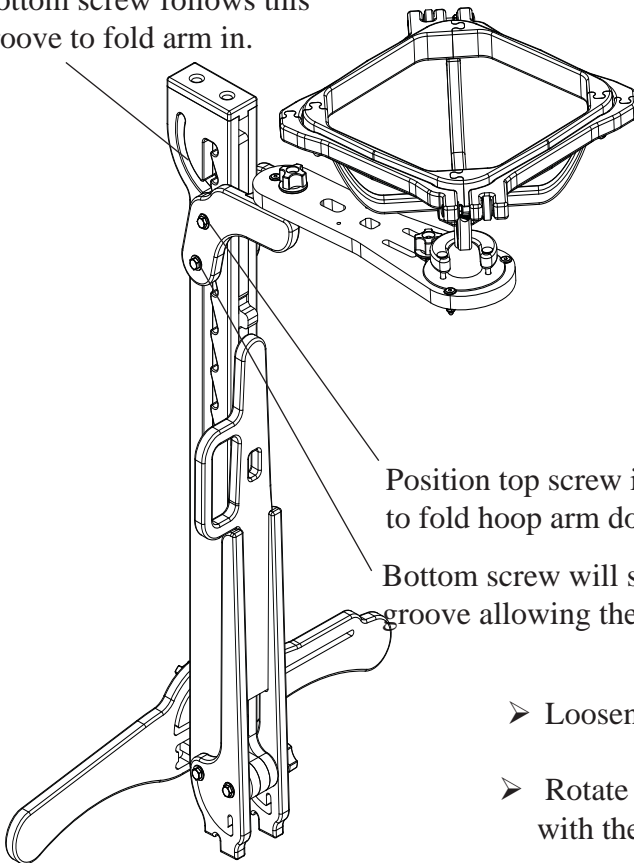

Position top screw in this notch to fold hoop arm down

Bottom screw will slide up the groove allowing the hoop to fold in.

- Loosen the arm height adjustment knob.
- Position the top screw within the arm into the highest notch.
- The bottom screw slides up the groov in the stand allowing the hoop to slide in towards the stand.
- Once the hoop is collapsed into the stand, you may tighten the hoop arm adjustment now to prevent the arm from moving in storage.

- Loosen the back foot adjustment knob.
- Rotate the back foot counterclockwise so that the foot is parallel with the leg of the stand as shown below.
- Retighten the back foot adjustment knob to secure it into place for storage.

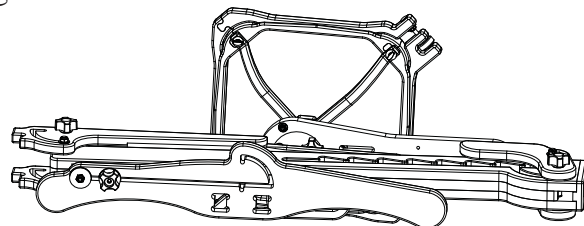

* **NOTE:** You do not have to remove your hoop for storage. Simply fold the hoop stand as directed above with the hoop attached for easy storage.

EdgeTool™ Assembly

Use the EdgeTool as an extension of your quilt while completing your borders and corners.

Parts Needed:

2 – Cloth Sleeves (Muslin recommended (not included))

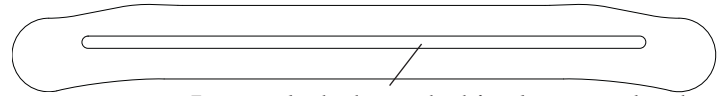

Insert cloth through this slot to make the sleeve for the EdgeTool™.

Cut two pieces of fabric to the following dimensions:
12" X 24" (Finished Size: 11" x 23")

Serge around the edges of both pieces. Insert one end of the fabric through slot located on the EdgeTool™. Pull the end of the fabric to the meet the other end of fabric, forming a loop with the EdgeTool™ in the center. Serge or sew the edge together all the way around the loop.

Repeat this step for the second EdgeTool™.

The cloth on the EdgeTool™ is pinned to the edges of your fabric to create the desired amount of side-to-side tension. (See "Using the EdgeTools" below)

When the cloth on the EdgeTool™ needs to be replaced, simply cut the cloth from the EdgeTool™. Follow the steps above to replace the fabric on the EdgeTool™.

Using The EdgeTools™

The EdgeTool™ will assist you in finishing your quilts along the edges. When you come to the edge of your quilt, lay the quilt on a flat surface and pin the EdgeTool™ cloth sleeve to all three layers at the quilt's edge. Pin as straight as possible.

Holding the EdgeTool™ and quilt, position them onto the inside hoop, letting the EdgeTool™ wood bar hang over the inside hoop and act as a weight to assist in the positioning of your quilt. Apply the outside hoop so that it clamps down over the EdgeTool™ cloth sleeve.

Installing Fabric and Use of the GraceHoop²™ 2005

Installing Fabric and Using The GraceHoop²™ 2005

Remove the outside hoop and drape your basted quilt over the inside hoop. Position the quilt so the desired work area is centered in the hoop. Place the outside hoop on the inside hoop, one corner at a time, until it rests completely on lip on the inside hoop.

Applying the outside hoop will evenly pull the fabric top-to-bottom, and side-to-side, If greater tension is desired, tighten the outside hoop using the outside hoop adjustment wheels.

After completing your work area, simply loosen the outside hoop, remove it and reposition your quilt. The square boundaries will make determining your next work area easy.