

Quilting with The
GraceHoop²™ Patent Pending
The GraceHoop – Squared Polymer Pro

Table of Contents

Customer Service Information.	2
Care, Finishing and Storage.	2
Warranty.	2
Parts List.	3-5
Ball Swivel/Bracket/Hoop Sub-Assemblies	6-9
Step 1 Ball Assembly	6
Step 2 Bracket Housing Assembly.	6
Step 3 Ball to Bracket Housing Assembly.	7
Step 4 Clamp Shoe/Ball Housing to Bracket Assembly.	7
Step 5 Inner Hoop to Brackets.	8
Step 6 Outer Hoop Sub-Assembly.	9
Wood Parts Assembly.	9-11
Step 1 Install Hardware to Upright Stand.	9
Step 2 Stand to Front Base Leg.	10
Step 3 Rear Base Leg to Upright Stand.	10
Step 4 Cantilever Arm to Stand.	10
Step 5 Ball/Bracket/Hoop Assembly to Cantilever Arm.	11
EdgeTool Assembly	11
Rotating and Adjusting the GraceHoop ² ™	12
Height Adjustment	12
Folding the GraceHoop ² ™	12-13
Basting Instructions.	14
Installing Fabric.	15
Using The EdgeTool™.	15-16
Other Grace Products.	17-18

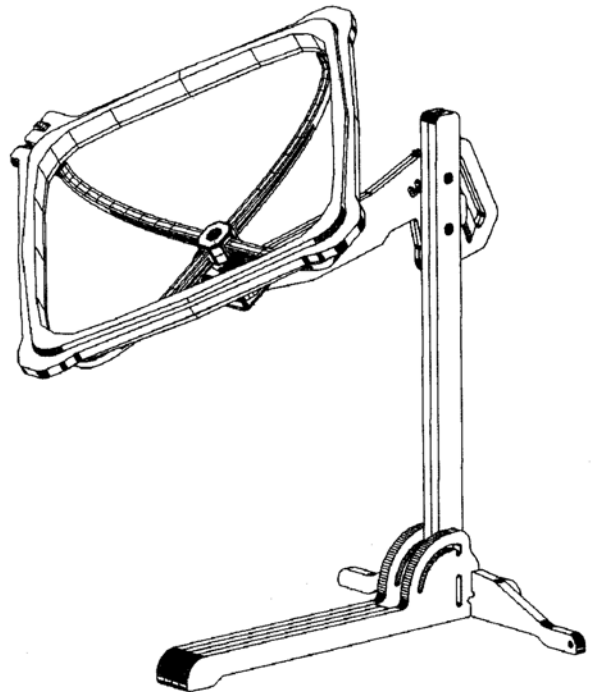

Copyright July 2000
 Jim M. Bagley, GraceWood, Inc.
 Reproduction Prohibited,
 Patent Pending

Care of Your GraceHoop²™

The GraceHoop²™ PolymerPro is made from the highest quality Baltic Birch Plywood and Polymer parts. The wood parts may be sealed and/or stained with an application of tung oil which will help preserve the wood and will help to prevent warping. Test stain on an inconspicuous place. Many different finishes and/or stains may be suitable for sealing and beautifying your hoop. You may want to consult your local paint retailer for finishes which will apply easily and dry hard—not oily.

Tip:

–Store the hoop in a dry place—preferably with the stand in vertical position.

Lifetime Limited Warranty Information

GraceWood, Inc. will replace or repair, at our discretion, any part of the GraceHoop²™ with problems due to manufacturing or workmanship. This warranty does not cover parts damaged through misuse, improper storage, improper assembly, loss, natural events, and willful or accidental destruction. Parts must be returned to the Grace Company, shipping prepaid, before we can replace them. We will promptly return the repaired or replaced part at our expense if done within a year of the purchase date. After one year customers are responsible for the cost of return shipping. Customers will never have to pay the cost of a part covered by the lifetime warranty.

Address For Shipping of Materials to Grace Co:

801 W. Layton Ave.
Salt Lake City, UT 84104

For Regular Correspondence:

P.O. Box 27823
Salt Lake City, UT 84127

Technical Support:

1-(801)-972-5801
Office Hours from 8 am to 4:30 pm MST

(Leave a message after hours; all calls will be returned).

Please report any errors in these instructions or make constructive comments to the P.O. Box or any of the following: FAX: (801)908-8888 ~ E-mail: info@graceframe.com

The GraceHoop²™ PolymerPro is a new product with several original design innovations. Our products are tops in functionality and ease-of-use, due in large part to the feedback we have received from the thousands of customers who use our products. If you have any suggestions that will help us to improve our product or service, please write to The Grace Company.

We have included a new tool for your convenience in assembling and disassembling your Grace Quilting Frame/Hoop. This **WingGrip™** tool has two openings at different angles. Simply fit it over the wing nut and turn to tighten. With this tool, you can easily tighten a wing nut slightly more than by hand! (Be careful not to overtighten).

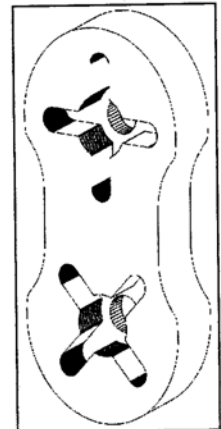

GraceHoop²™ Polymer Pro Large Parts List

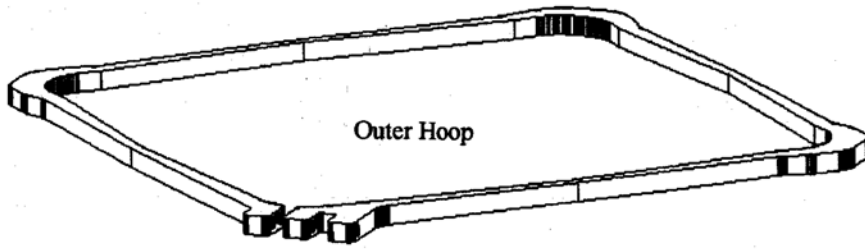

Outer Hoop

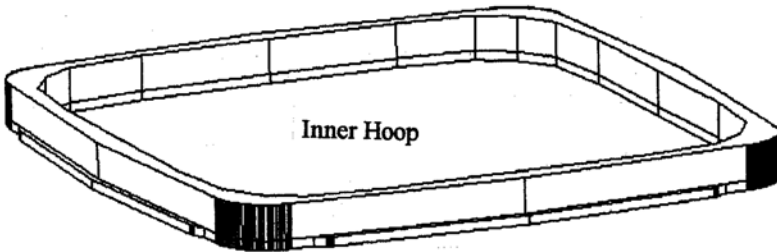

Inner Hoop

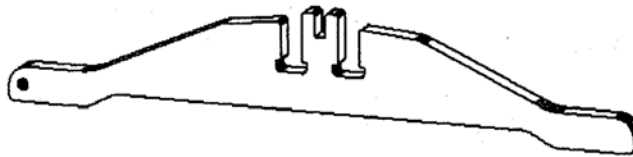

Rear Base Leg

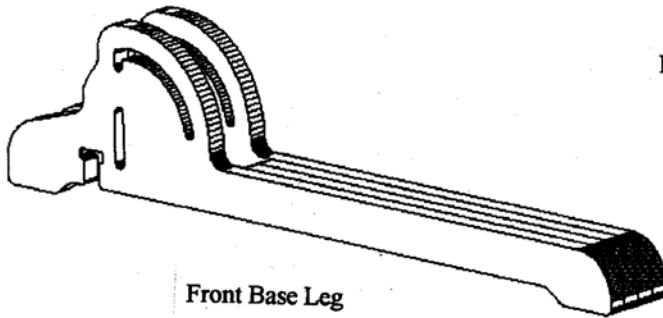

Front Base Leg

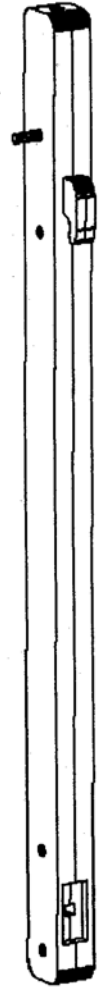

Bolt Pre-Installed

Upright Stand



4 - Hoop Bracket

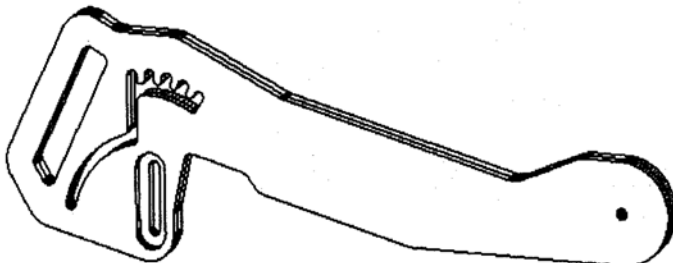

Cantilever Arm



4 - EdgeTool™ Reversible Part

GraceHoop²™ Polymer Pro Small Hardware Parts List



1 - 5/16" x 5" Carriage Bolt
Ball Stem/Bracket Assembly

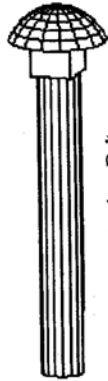

2 - 5/16" x 2 1/2" Carriage Bolt
(one for Stand, one for Clamp Shoe)



1 - 1/4" x 4" Carriage Bolt
Outer Hoop



1 - 5/16" x 3" Carriage Bolt
Stand/Rear Base Leg Assembly



2 - 5/16" x 3 1/2" Hex Head Bolt
Stand to Base Leg Assembly



9 - 5/16" Flat Washers (medium)

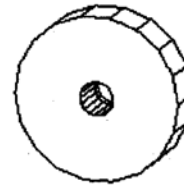

1 - 1/4" Knurled Finger Nut
Outer Hoop



2 - #8 Lock Washers
Ball Housing



1 - 5/16" Nylock Nut
Cantilever Arm to Stand Assembly



1 - 1/4" Hex Nut
Outer Hoop



3 - 1/4" Flat Washers (smallest)
Outer Hoop



2 - Jamb Nuts
Upright Stand



2 - #8 Nuts
Ball Housing



4 - #8 x 1 1/2" Screws
Ball Housing



16 - #8 x 7/8" Screws



4 - #8 x 1" Screws
Bracket Housing Screws



4 - #8 x 5/8" Screws
EdgeTool (Outer Holes)



2 - #8 Machine Screws
Ball Housing Adjustment Screws

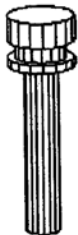

4 - 1/4" Nylon Thumb Screws

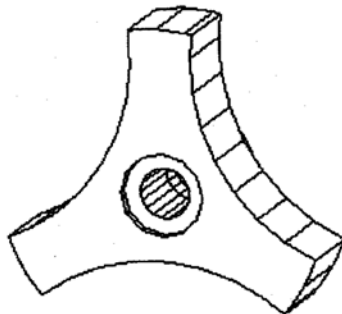

2 - Triple Wing Knobs



2 - 1 1/2" Fender Washers (largest)



4 - Wing Nuts

GraceHoop²™ Polymer Pro Ball Swivel Parts List

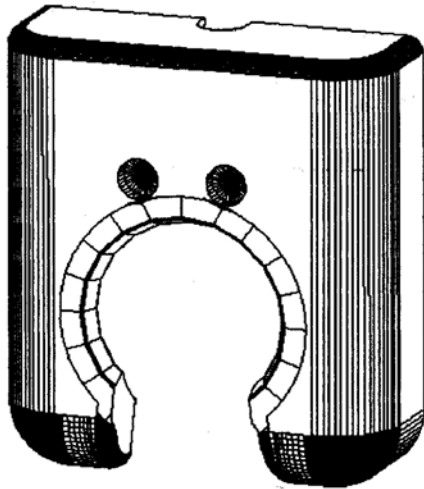

Top Ball Housing

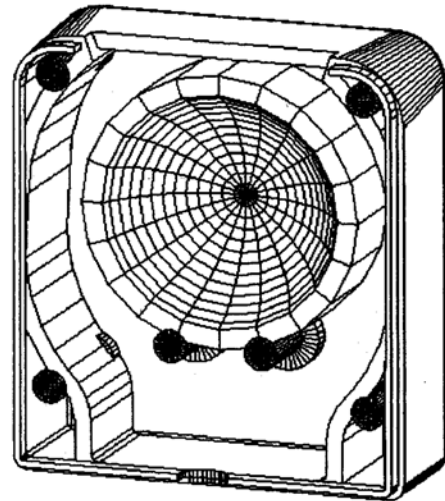

Bottom Ball Housing

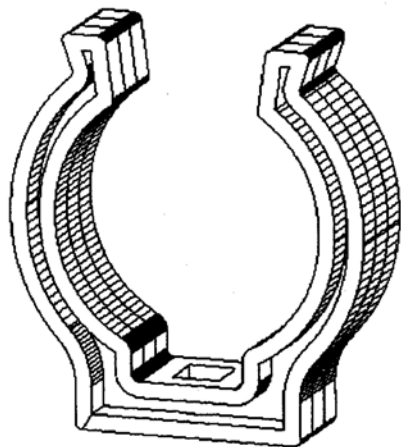

Clamp Shoe

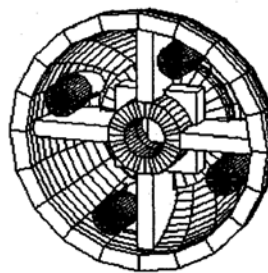

Bottom Ball Segment

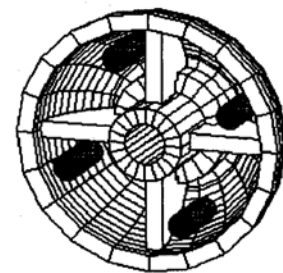

Top Ball Segment

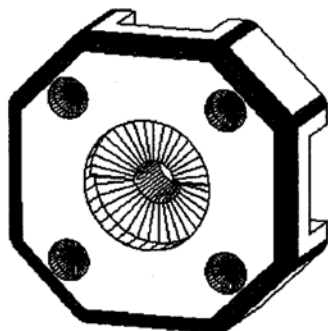

Bracket Housing Bottom

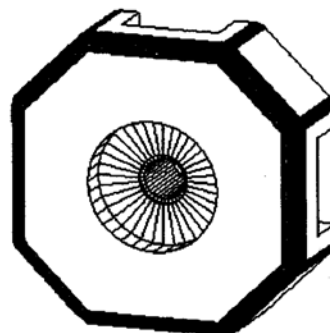

Bracket Housing Top

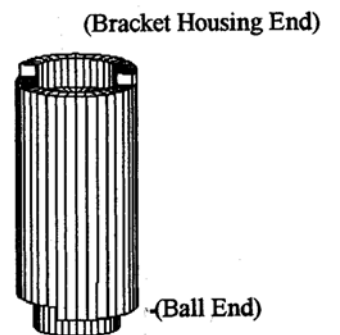

Ball Stem

Assembly of The GraceHoop²™ Polymer Pro

Tools Needed For Entire Product Assembly:

Phillips Head Screw Driver
7/16" socket or regular wrench
1/2" socket or regular wrench

**Please note: For your convenience, we have separated the hardware into three bags. Locate and keep separate the EdgeTool Hardware bag (pg.11), the Ball Swivel/bracket sub-assembly bag (pgs.6-8), and the main hardware bag (pgs.8-11).*

BALL SWIVEL/BRACKET SUB-ASSEMBLIES

Step 1: Ball Assembly

Parts Needed: 1 - Top Ball Segment
1 - Bottom Ball Segment
1 - Ball Stem
4 - 7/8" Screws

Put the Top and Bottom Ball Segments together, lining up the holes. The Bottom Ball Segment has the holes going all the way through.

Using a Phillips Head screw driver, insert and tighten the four 7/8" screws into the Bottom Ball Segment ball section.

Insert the Ball end (see Ball Swivel parts list) of the Ball Stem into the top of the ball. Carefully Line it up so that the stem seats into the hole.

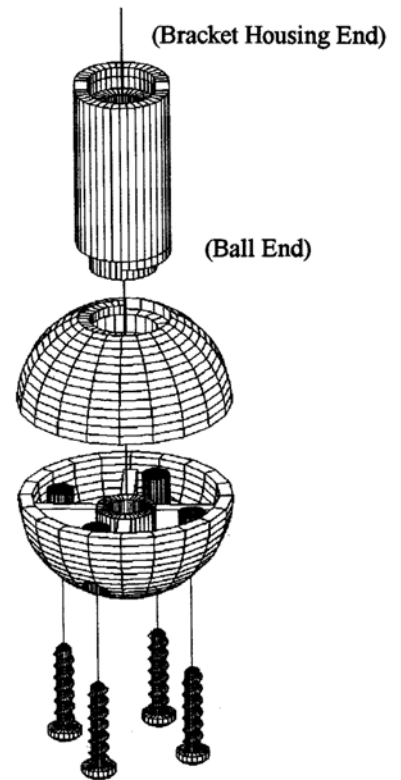

Step 2: Bracket Housing Assembly

Parts Needed: 1 - Bracket Housing Top
1 - Bracket Housing Bottom
4 - Hoop Brackets
4 - 1" Bracket Housing Screws

Position the four brackets into the Bracket Housing Bottom as pictured. The Bottom is the half with the through holes. Fit the Bracket Housing Top of the brackets.

After sandwiching the four brackets with the Housing Top and Bottom, insert and tighten the four 1" screws up through the Bracket Housing Bottom..

Completely tightening the screws will fasten the Top and Bottom housings around the brackets.

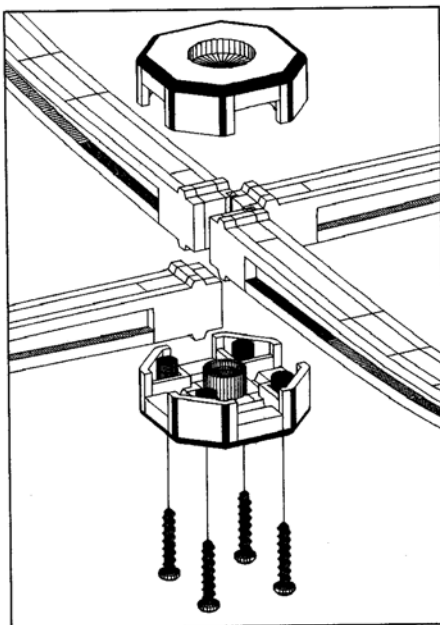

Step 3: Ball Assembly to Bracket Housing Assembly

- Parts Needed:
- 1 - Bracket Housing Assembly
 - 1 - Ball Assembly
 - 1 - 5/16" x 5" Bolt
 - 1 - 5/16" Flat Washer (medium)
 - 1 - 5/16" Wing Nut

Place the carriage bolt into the bottom of the ball assembly.

IMPORTANT: Be sure you fit the square head of the bolt into the square hole in the ball. If this is done correctly, you should not be able to turn the bolt while in the ball. If you can turn the bolt, it is not seated completely!

Now fit the Ball and Bracket Assemblies together as pictured, so the bolt comes completely through the bracket assembly. Put the flat washer onto the bolt and begin the thread the wing nut onto the bolt.

NOTE: The flat washer may not automatically seat into the recessed slot. As you tighten the wing nut down, this will force the washer down into the its slot forming a flat surface.

Using the special WingGrip™ (see right) tool included with your product, you may firmly tighten the wing nut. (See note on bottom of page 2)

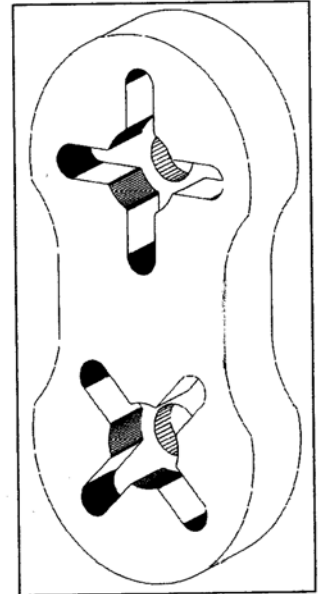
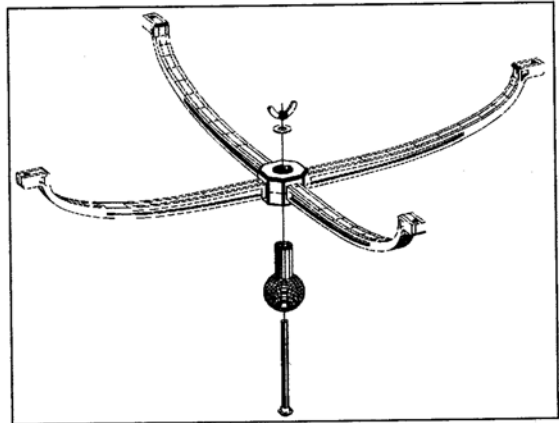

Step 4: Clamp Shoe/Ball Housing Assembly

- Parts Needed:
- 1 - Polymer Clamp Shoe
 - 1 - 5/16" x 2 1/2" Carriage Bolt
 - 1 - Bottom Ball Housing
 - 1 - Top Ball Housing
 - 1 - Ball/Bracket Assembly
 - 4 - 1 1/2" Screws
 - 2 - 2" Machine Screws
 - 2 - Lock Washers
 - 2 - #8 Nuts

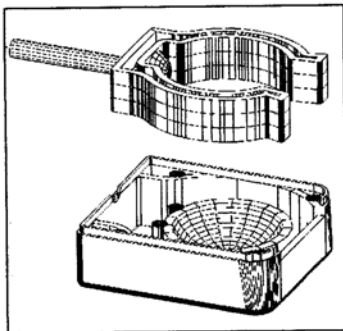

Insert the carriage bolt into the clamp shoe as pictured. **IMPORTANT:** Be sure to seat the bolt completely so that round head sits flush against the shoe. If this is done correctly you should not be able to turn the bolt in the hole.

Fit the clamp shoe into the Bottom Ball Housing as shown (left). The ends of the shoe will extend slightly over the housing.

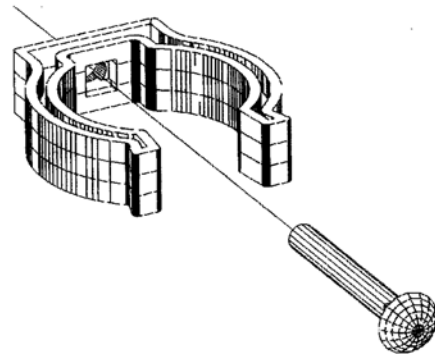

As you complete the remaining steps of this assembly, be sure the bolt remains completely seated so you are unable to turn it.

With the shoe clamp in place, next fit the Bottom Ball Housing into the Ball Assembly and Top Ball Housing. Fasten these together by inserting and tightening the four 1 ½" screws through the Bottom Housing.

For proper performance of the clamp shoe, there are two machine screws that must be inserted (see below). These go into the holes in the Top Ball Housing

First place the lock washers onto the screws, and place the #8 nuts into the hex-holes in the Bottom Ball Housing.

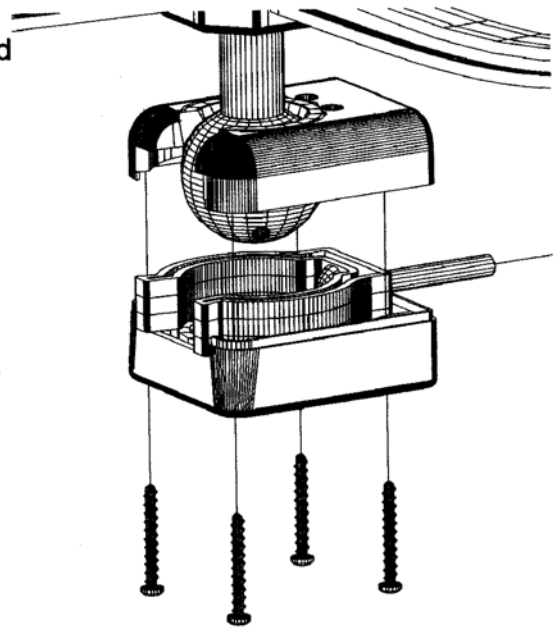

As you insert the screws into the holes, through the housing, thread the screws through the nuts. Continue tightening using a Phillips head screw driver.

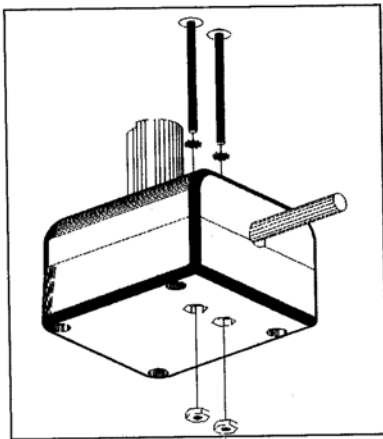

Keep in mind that these are adjustment screws intended to help the ball tighten and lock properly. **BE CAREFUL NOT TO OVER TIGHTEN THESE SCREWS.** If movement of the ball is rigid, you may need to loosen these slightly.

Step 5 : Inner Hoop to Brackets

Parts Needed: 1 - Polymer Inner Hoop
1 - Ball Swivel/Bracket Assembly
4 - Nylon Thumb Screws

Locate the metal inserts imbedded into each corner of the inner hoop. Hold the hoop so that these inserts face down.

Align Inside Hoop on top of the hoop brackets so that metal inserts fit directly over the bracket ends.

IMPORTANT: When threading the nylon screws, they should start easily. If they do not start easily, do not try to force them. This will cross-thread the nylon screws causing them not to work. Rotate the thumb screw and try to start it again, until it begins to thread easily. Continue with each corner until the Inner Hoop is secured onto the brackets.

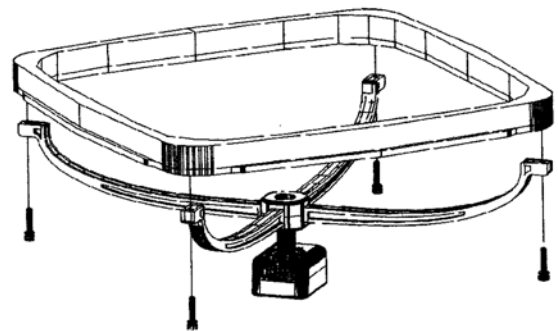

Step 6 : Outer Hoop Sub-Assembly

- Parts Needed:
- 1 - Polymer Outer Hoop
 - 1 - 1/4" x 4" Carriage Bolt
 - 1 - Knurled Finger Nut
 - 1 - Hex Nut
 - 3 - 1/4" (Smallest) Flat Washers

This assembly will make tension control on the outer hoop possible. First, position the outer hoop exactly as pictured.

Insert the 1/4" x 4" Carriage Bolt into the hole, coming from the left, so that it barely protrudes into the first opening. Next, in the first opening, place a 1/4" small Flat Washers and a 1/4" Hex Nut onto the bolt.

Continue threading until completely tightened. Now push the bolt into the second opening and place another 1/4" washer onto it, followed by the Knurled Finger Nut and another 1/4" washer.

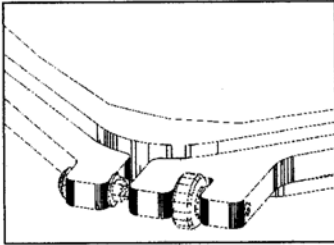

Now, loosen the tension of the outer hoop by turning the Finger Nut. Fit it over the Inside Hoop, resting it on the lip of the Inner Hoop.

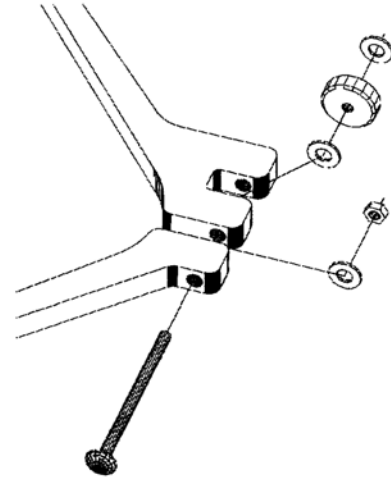

WOOD PARTS ASSEMBLY

Step 1: Install Hardware to Upright Stand

- Parts Needed:
- 1 - Upright Stand
 - 1 - 5/16 x 2 1/2" Carriage Bolt
 - 1 - 5/16 x 3" Carriage Bolt
 - 2 - 5/16 Flat Washers
 - 2 - 5/16 Jamb Nuts

Insert the Carriage Bolts into the holes of the stand as pictured. Be sure the 2 1/2" bolt is at the top of the stands, with the 3" bolt at the bottom.

Thread a 5/16" Flat Washer and Jamb Nut onto the end of the two bolts you inserted. No washer or nut will go on the pre-installed bolt.

Tighten both nuts completely so that the round heads of the Carriage bolts are drawn completely to the wood.

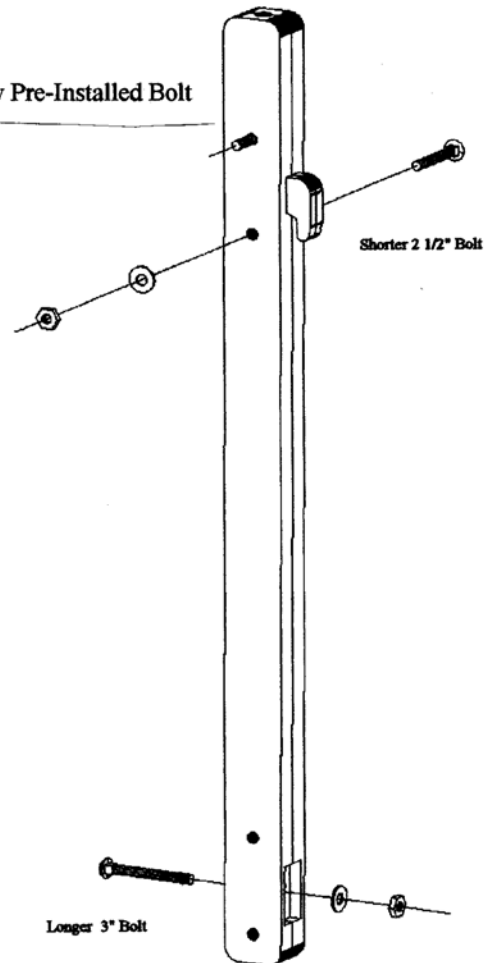

Step 2: Stand to Front Base Leg

- Parts Needed:
- 1 - Upright Stand
 - 1 - Front Base Leg
 - 2 - 5/16" x 3 1/2" Hex Head Bolts
 - 4 - 5/16" Flat Washers
 - 2 - 5/16" Wing Nuts

Position stand into the front base leg (as pictured) so that the lower bolt points out toward the back of the leg.

Locate the 5/16" x 3 1/2" Hex Head Bolts.

Hold the stand so that the side holes are visible through the slots in the leg piece. Put 5/16" flat washers on both bolts and insert the bolts through the slots and holes.

Once through the other slots, place another 5/16" Flat Washer on the end of each bolt followed by a 5/16" Wing Nut.

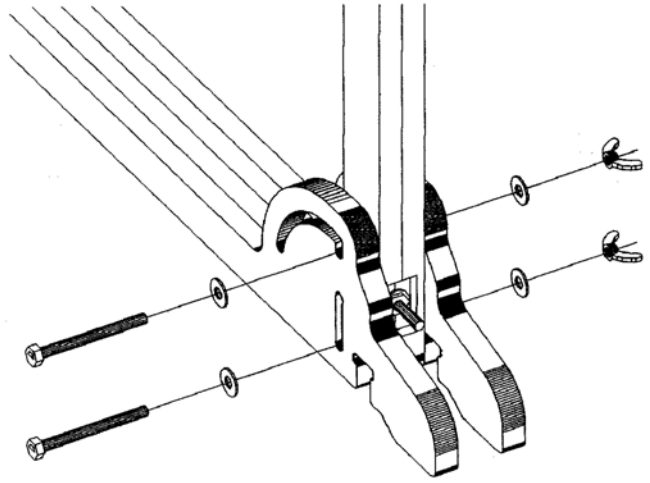

Step 3: Rear Base Leg to Upright Stand Assembly

- Parts Needed:
- 1 - Upright Stand Piece/Front Base Leg Assembly
 - 1 - Rear Base Leg
 - 1 - 5/16" Flat Washer
 - 1 - 5/16" Wing Nut

Slide the Rear Base Leg into slots underneath the front base leg near the upright stand.

The protruding bolt at base of stand should fit into the slot at the top of the Back Base Leg. Place a 5/16" washer and wing nut onto the bolt and completely tighten to secure the Rear Base Leg to the Stand assembly.

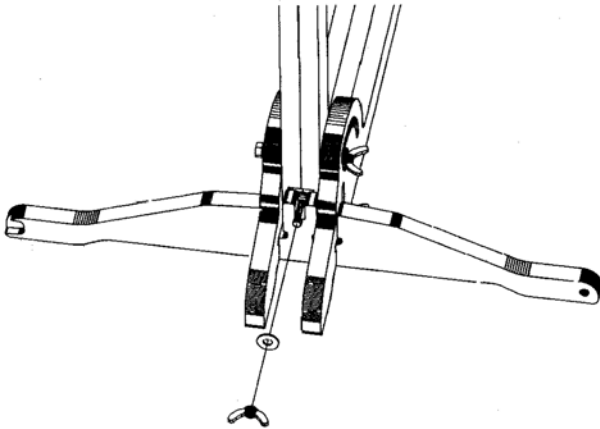

Step 4: Cantilever Arm to Stand Assembly

- Parts Needed:
- 1 - Stand Assembly With Legs
 - 1 - Cantilever Arm
 - 1 - 5/16" Flat Washer
 - 1 - 5/16" Nylock Locking Nut
 - 1 - 5/16" Three-Wing Knob
 - 1 - 1 1/2" Fender Washer (largest)

The Cantilever Arm will fit onto the two bolts extending from the upper part of the stand. Place the Arm so that the lower bolt slides through the straight

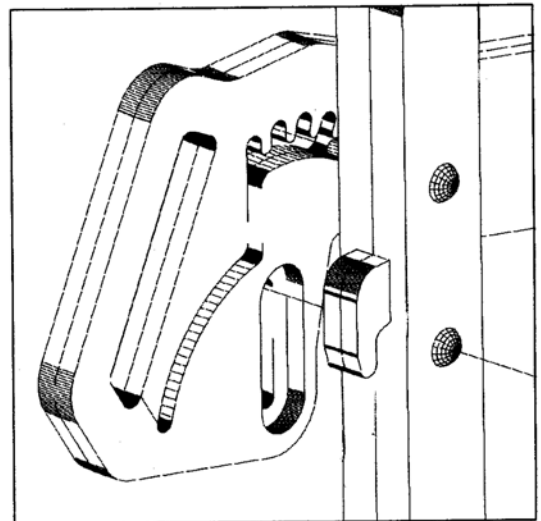

lower slot. Also note that the recessed slot faces the stand. The upper bolt slides through the ratched slot.

Apply the 1 1/2" Fender Washer and Three-Wing Knob onto the upper bolt.

Apply 5/16" Washer and Nylock Locking Nut onto the lower bolt. Tighten the lock nut until it is just a couple of threads away from the washer. **DO NOT TIGHTEN LOCK NUT COMPLETELY TO THE WASHER.** The bolt should slide in the slot freely, but not sloppily.

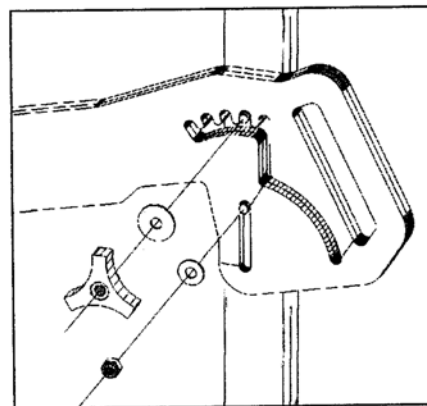

Step 5: Ball Swivel/Bracket/Hoop Assembly to Cantilever Arm

- Parts Needed
- 1 - Ball/Bracket/Hoop Assembly
 - 1 - Cantilever Arm
 - 1 - 1 1/2" Fender Washer (largest)
 - 1 - Three-Wing Knob

Place the bolt that protrudes out the back of the Ball Assembly through the hole of the Cantilever Arm.

For proper balance, the assembly should be on the same side of the Cantilever Arm as the stand (see picture).

Put the washer on the bolt followed by the knob. Tightening the knob will lock the ball swivel into place.

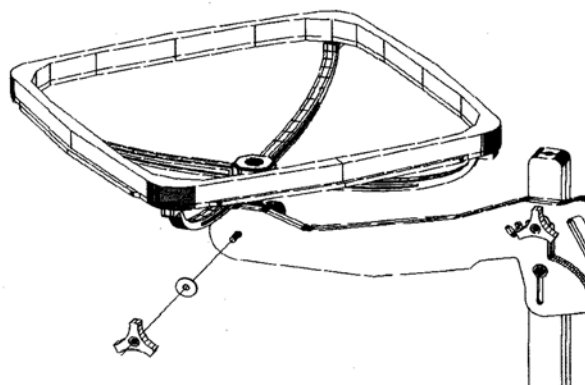

You have completed Assembly on your New GraceHoop²™!

EdgeTool™ Assembly

- Parts Needed
- 2 - EdgeTool™ Reversible Parts
 - 12 - 7/8" Screws
 - 4 - 5/8" Screws
 - 2 - 16" x 6" Cloth Sleeves (Muslin or Ticking) Not Included

For 24" hoop:

First make the cloth sleeve by folding a 32" x 6" piece of muslin or ticking in half long ways (to make a 16" x 6" piece). Place to two edges in between the EdgeTool™ Reversible Parts. Insert the six 7/8" screws into the six inner holes. Insert the two 5/8" screws on the two outside holes.

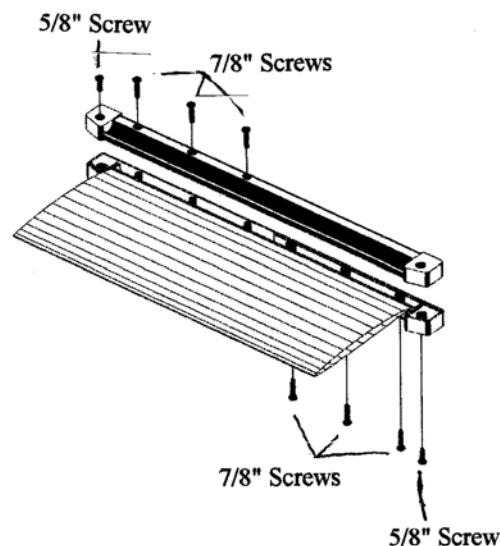

For the 18" or 14" hoop sizes, following the above instructions using the following cloth measurements:

- 18" hoop: 22 1/2" x 6" (folded to 11 1/4" x 6)
- 14" hoop: 18 1/2" x 6" (folded to 9 1/4" x 6)

Rotating and Adjusting the GraceHoop²™

Rotation

The GraceHoop²™ is the most adjustable hoop ever made. It is capable of 360-degree rotation in two different directions. These are both controlled by the Three-Wing Knob that attaches the SureLock™ Ball Swivel Clamping Unit to the Cantilever Arm.

Horizontal Hoop Rotation: Loosening the Three-Wing Knob allows you to rotate the hoop horizontally. The hoop can be completely and repetitively rotated, but it is recommended that the rotation direction always be clockwise so as not to loosen the wing nut that secures the hoop and brackets to the Ball Swivel Clamping Unit.

Vertical Hoop Rotation: Loosening the knob will also allow you to tilt the hoop vertically. You can achieve any degree of slant possible, because of the movement of the Ball Swivel and the Clamping Unit itself. It is even possible to position the hoop upside-down.

Before you begin quilting, we recommend that you install a quilt, sit down, and experiment with the hoop and its rotational capabilities. You may even experiment sitting at different sides of the hoop.

Height Adjustment

The ratchet design in the Cantilever Arm provides you with seven different height settings at which you may quilt. There is a two-foot span between the highest and lowest setting, making it possible for you to quilt while standing or sitting on a tall stool; while lying in bed, or even sitting on the floor.

To adjust the height, loosen the Three-Wing Knob that connects the Arm to the Upright Stand. Pull the arm straight up to get the bolt out of the current setting and angle the arm to reset it in the desired slot. **BE SURE THE BOLT IS FIRMLY RESTING IN THE DESIRED SLOT, OTHERWISE IT MAY SUDDENLY SLIDE DOWN ON YOU!**

Folding the GraceHoop²™

The GraceHoop²™ folds down to an easy-to-store, or easy-to-carry unit. Folding is achieved with the following Six Easy Steps:

Step 1: Turn the ball swivel to a 90-degree tilt setting (as pictured). The Sure-Lock Ball Swivel Clamping Unit should be level, with the dowel-end of the ball swivel perpendicular to the arm.

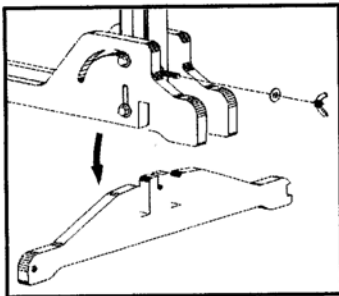

Step 2: Remove the Rear Base Leg by taking the 5/16" wing nut and washer off the back bolt, and sliding the Rear Base Leg out

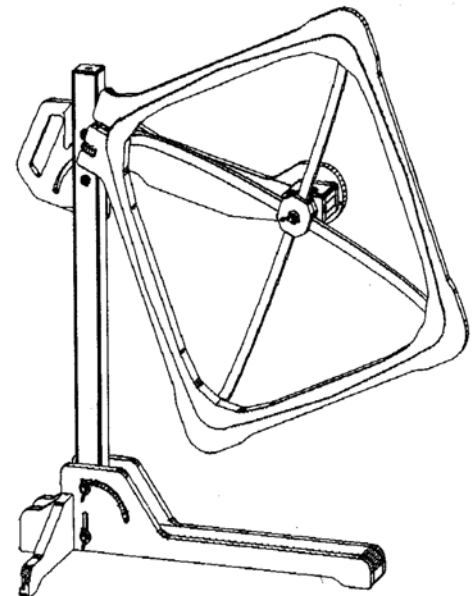

of the slots. Then, loosen the wing nuts on the other two bolts at the base of the Upright Stand and lift the stand 3/8" to unlock the swivel joint that holds the Stand upright.

Step 3: Swing the Front Base Leg 90-degrees until it becomes parallel with the Upright Stand. Re-tighten the two wing nuts at the stand's base to hold this position.

Step 4: Loosen the Three-Wing Knob connecting the Arm and Stand. (A) Lift the arm straight up, let it pivot all the way down until it passes the last notch, then (B) lift the arm in the direction of the bottom slot about two inches. Let the arm pivot further until the top bolt rests at the bottom of its slot. This will bring the Arm parallel to the stand, sandwiching in the Front Base Leg.

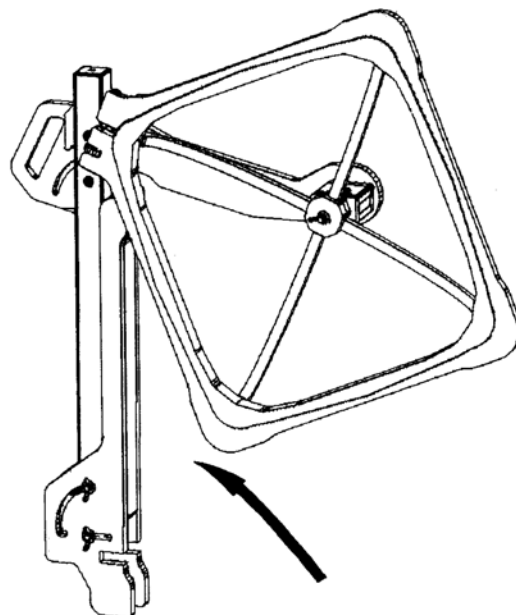
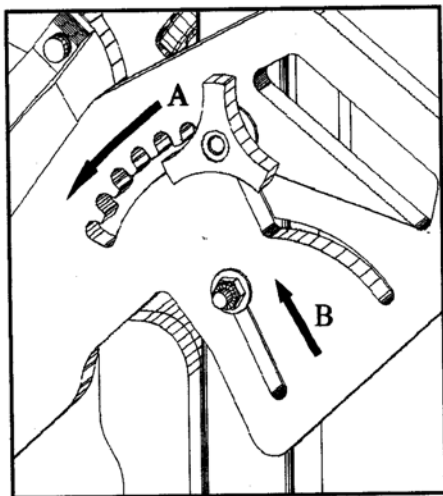

Step 5: With the GraceHoop²™ completely folded, re-tighten all the wing nuts and knobs to secure the position.

Step 6: Attach the Rear Base Leg to the top of the Stand by inserting the notched end of the Base Leg under the Leg Fastener. The hole on

the opposite end of the leg will slide onto the back bolt. Reapply and tighten down the washer and wing nut onto this bolt to secure the Leg.

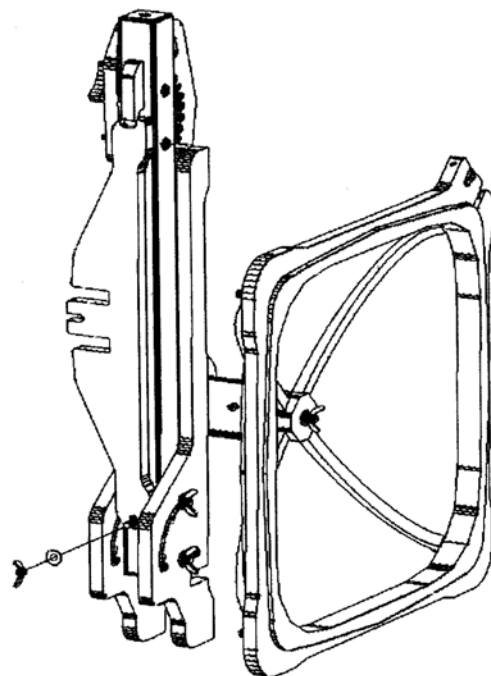
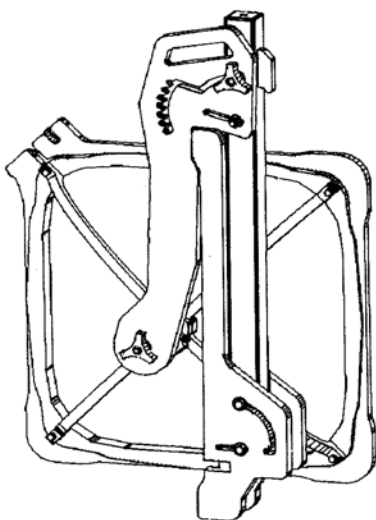

Basting Instructions and Tips

Basting Method I: Fabric Rolling on a Frame

This is best accomplished on a three or four-rail Grace Quilting Frame. Follow your GraceFrame™ instructions for fabric lining installation. The frame will hold the fabric and batting materials evenly and smoothly, assuring a smooth and evenly basted quilt.

Begin stitching from one edge of the quilt near the rail closest to you. Baste horizontally using an even-running stitch. Baste to the other edge, and then stitch the second line going the opposite direction, making your basting lines about 2 to 4 inches apart. Follow this pattern of stitching throughout the rest of the quilt.

IMPORTANT: When rolling the quilt to the next work area, *do not over roll!* Rolling the last row of stitching over the rail—even part-way—may cause puckering. This is easily overcome by leaving one row of stitching completely visible on the flat plane of the working area.

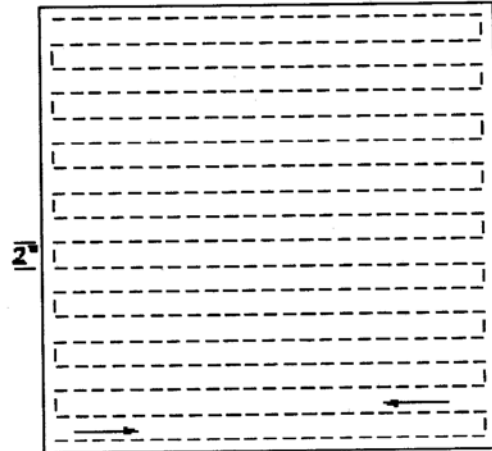

Basting Method II: Starburst

(1) Cut and sew the backing fabric together to be at least 2 or 3 inches larger than the top on all sides.

(2) Press all the seams open flat. Fold the backing in-half longways and finger crease the center and lightly mark the top and bottom edges in the center.

(3) Place the backing on a smooth, flat surface that is a little larger than the backing. Place the backing fabric with the right-side down. Be sure it is free of wrinkles. You may even use masking tape to make the backing smooth.

(4) Unfold the batting and layer it carefully over the backing. Smooth out all the wrinkles. The batting should be about the same size as the backing.

(5) Fold the top fabric in-half lengthwise and lightly mark the center at the top and bottom edge. Carefully lay the top over the batting layer. Be sure the center marks of the backing and the top match up. Again, smooth out all the wrinkles. You can use straight pins to hold the layers together while basting.

To do the actual basting, use a large needle with thread. Starting in the center, baste with large stitches. First baste from edge to edge up the vertical center of the quilt. Then baste from edge to edge across the horizontal center of the quilt. Continue to baste in a starburst fashion (see picture) working from the center out, until all layers are completely stabilized.

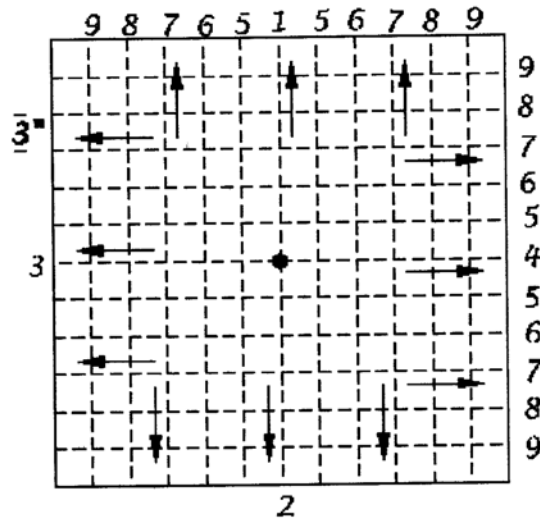
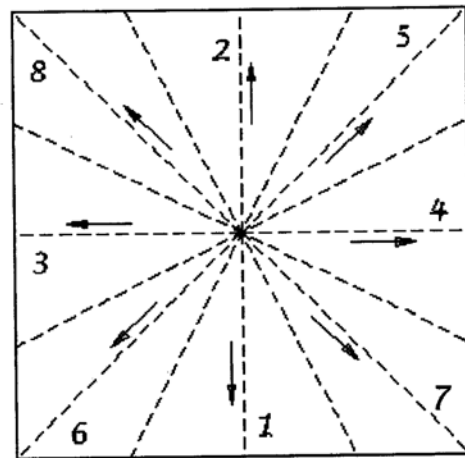

Basting Method III: Square-Stitch

This method is best for large quilts, and should be done on the floor. This method is very similar to Method Two in that the first Five steps are identical. After completing the two edge-to-edge stitches, follow the diagram, row-by-row outward, keeping lines about 2 to 4 inches apart. Always start a new line from the center stitch and then go the opposite direction from the center stitch.

****NOTE:** These are only a few suggestions on basting your quilt. There may be many other good methods. If you take the time to baste your quilt accurately, your quilt will finish better.

Installing Fabric and Use of the GraceHoop²™

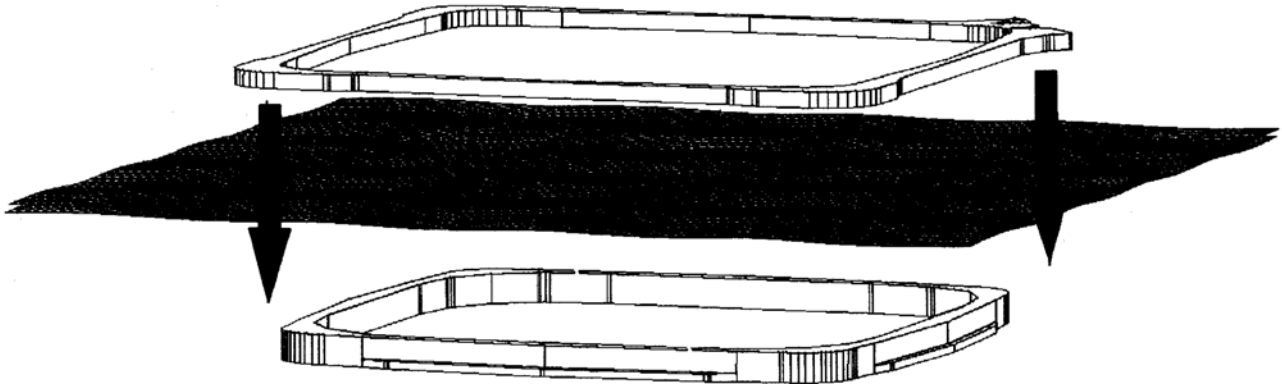

Following the diagram, remove the Outside Hoop and drape your basted quilt over the Inside Hoop. Position the quilt so the desired work area is centered in the hoop. Place the Outside hoop over the Inside Hoop, one corner at-a-time, until it rests completely on the lip on the Inside Hoop.

Applying the Outside Hoop will evenly pull the fabric top-to-bottom, and side-to-side. If greater tension is desired, simply tug on the fabric outside of the hoop. Once the desired tension is achieved, tighten the Outside Hoop using the Large Finger Nut.

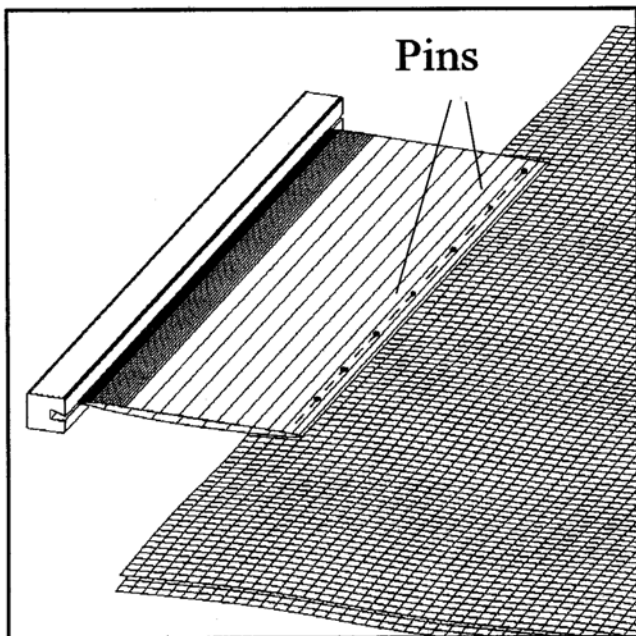

After completing your work area, simply loosen the Outside Hoop, remove it and reposition your quilt. The square boundaries will make determining your next work area easy.

Using the EdgeTools™

The EdgeTool™ will assist you in finishing your quilts along the edges. When you come to the edge of your quilt, lay out the quilt on a flat surface and pin the EdgeTool™ cloth sleeve to all three layers at the quilt's edge. Pin as straight as possible.

Holding the EdgeTool™ and quilt, position them onto the Inside Hoop, letting the EdgeTool™

wood bar hang over the Inside Hoop and act as a weight to assist in the positioning of your quilt. Apply the Outside Hoop so that it clamps down over the EdgeTool™ cloth sleeve.

The EdgeTool™ comes as a set of two, enabling it to work in tandem as you complete the corners of your quilt (see diagram).

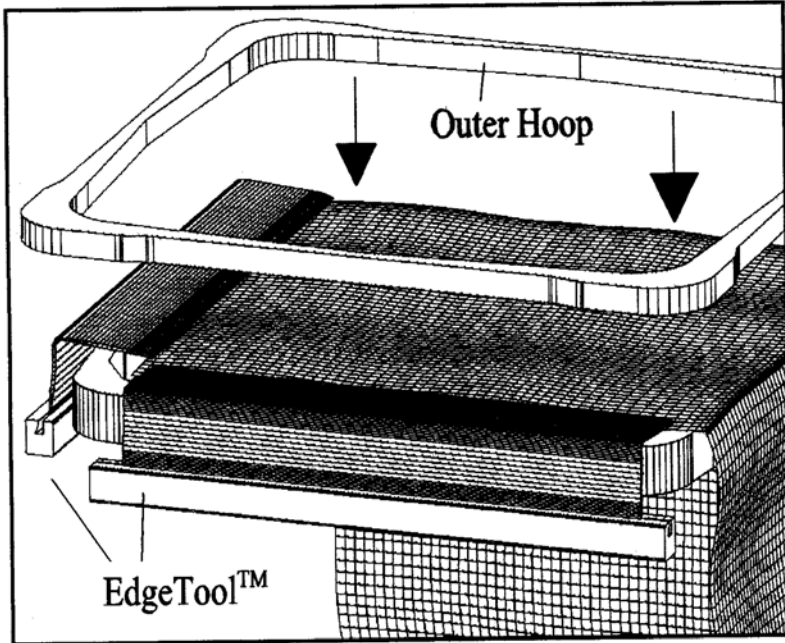
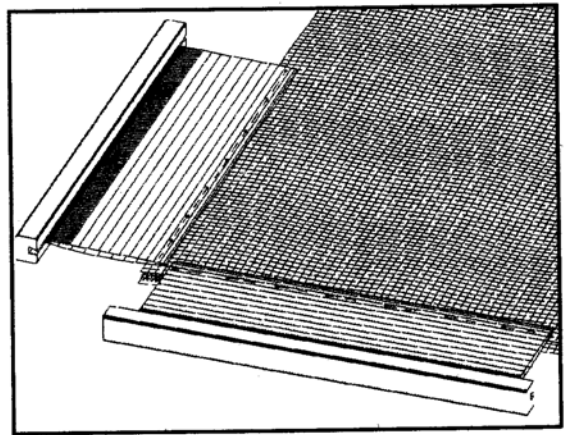

Lamp Holder

The hole at the top of the Upright Stand provides a place for you to insert a swing arm lamp. This hole will accommodate most lamp models. The Grace Company sells Swing Arm Lamps as an accessory.

Step 3: Ball Assembly to Bracket Housing Assembly

Parts Needed: 1 – Allen Wrench
 1 – Bracket Housing Assembly
 1 – Ball Assembly
 1 – 1/4" x 4" Carriage Bolt
 1 – Cap Nut

Place the carriage bolt into the bottom of the ball assembly.

IMPORTANT: Be sure you fit the square head of the bolt into the square hole in the ball. If this is done correctly, you should not be able to turn the bolt while in the ball. *If you can turn the bolt, it is not seated completely!*

Now fit the ball and bracket assemblies together as pictured, so the bolt comes up into the bracket assembly.

Put the cap nut into the hole and tighten onto the bolt using the provided Allen Wrench.

